



Attributes

- Steel construction
- Buckling design
- Axial to radial stiffness ratio 2:1
- Designed to carry static loads in the axial direction but can accommodate dynamic inputs in the radial direction
- Attenuates 18" freefall drop input to 12g's

Applications

- Shipboard equipment
- Transit cases
- Vehicle electronics
- Missile transportation
- Lab equipment

Load Range

- 1975-1 = load ratings to 45 lbs.
- 1975-2 = load ratings to 70 lbs.
- 1975-3 = load ratings to 100 lbs.
- 1975-4 = load ratings to 145 lbs.

Specifications

- Natural Frequency— 12-20 Hertz
- Transmissibility at resonance—10:1 max. for Neoprene, 5.1 max. for Polybutadiene
- Resilient Element— Neoprene
- Standard materials—Steel (Grounding Strap Beryllium Copper)
- Weight = 4 lbs.

Elastomeric Data

- Neoprene has an operating temperature range of -40°F to 200°F (-40°C to $+93^{\circ}\text{C}$) and is resistant to fungus and ozone
- Polybutadiene (low temperature) compound has an operating temperature range of -60°F to $+180^{\circ}\text{F}$ (-50°C to 82°C) and resists oil and ozone

Specifications subject to change without notice. Check with factory for latest revisions. The Federal Trade Commission considers no existing test methods or standards regarding flammability as accurate indicators of the performance of cellular plastic materials under actual fire conditions. Results of existing test methods, such as UL-94, MVSS-302, SAE J-369, and FAR 25.853 are intended only as measurements of the performance of such materials under specific controlled test conditions. Any flammability ratings shown are not intended to reflect hazards presented by these materials under actual fire conditions. The information contained herein is based on laboratory test data developed for PTI and is believed to be reliable, but its accuracy or completeness is not guaranteed. The buyer must test any product to determine the suitability for his specific application before use. PTI DISCLAIMS ANY RESPONSIBILITY FOR: 1) WARRANTIES OF FITNESS AND PURPOSE, 2) VERBAL RECOMMENDATIONS, 3) CONSEQUENTIAL DAMAGES FROM USE AND 4) VIOLATION OF ANY PATENTS OF TRADEMARKS HELD BY OTHERS.



Part #		Maximum Axial Load Ratings (lbs.)
Neoprene	Polybutadiene	
1975-1A	1975-5A	45
1975-2A	1975-6A	70
1975-3A	1975-7A	100
1975-4A	1975-8A	145

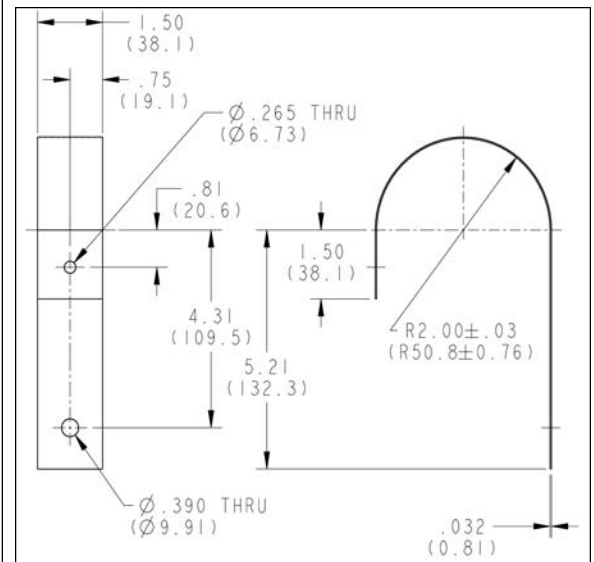
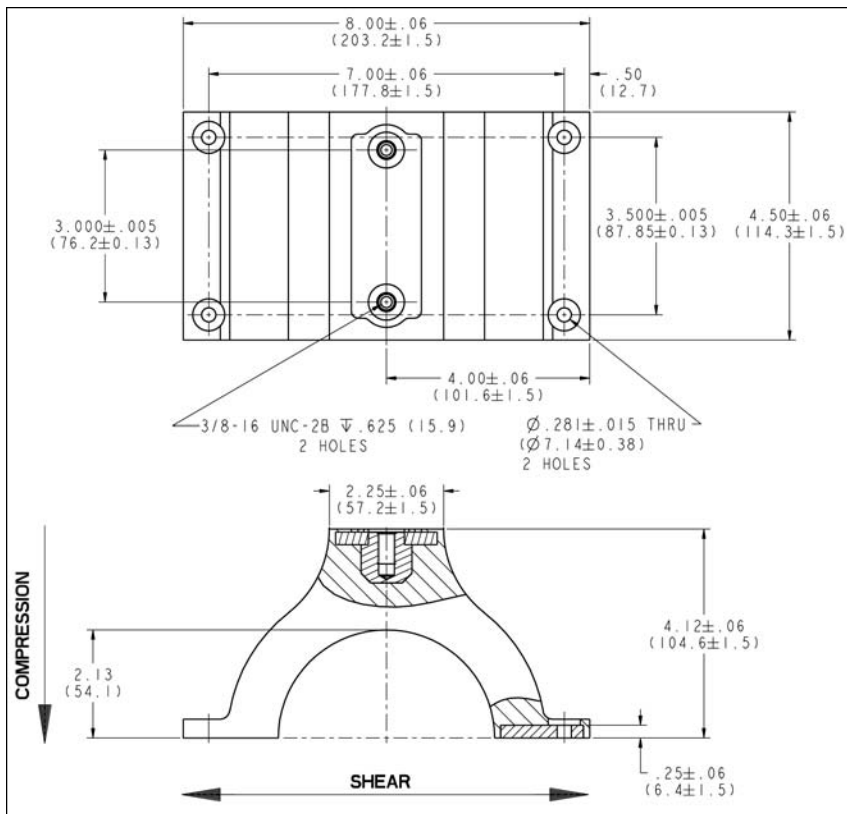

Specifications subject to change without notice. Check with factory for latest revisions. The Federal Trade Commission considers no existing test methods or standards regarding flammability as accurate indicators of the performance of cellular plastic materials under actual fire conditions. Results of existing test methods, such as UL-94, MVSS-302, SAE J-369, and FAR 25.853 are intended only as measurements of the performance of such materials under specific controlled test conditions. Any flammability ratings shown are not intended to reflect hazards presented by these materials under actual fire conditions. The information contained herein is based on laboratory test data developed for PTI and is believed to be reliable, but its accuracy or completeness is not guaranteed. The buyer must test any product to determine the suitability for his specific application before use. PTI DISCLAIMS ANY RESPONSIBILITY FOR: 1) WARRANTIES OF FITNESS AND PURPOSE, 2) VERBAL RECOMMENDATIONS, 3) CONSEQUENTIAL DAMAGES FROM USE AND 4) VIOLATION OF ANY PATENTS OR TRADEMARKS HELD BY OTHERS.

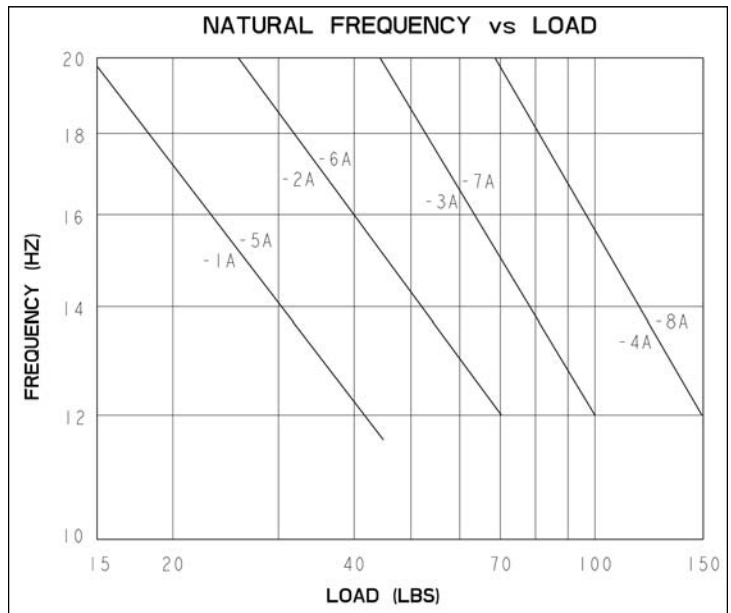
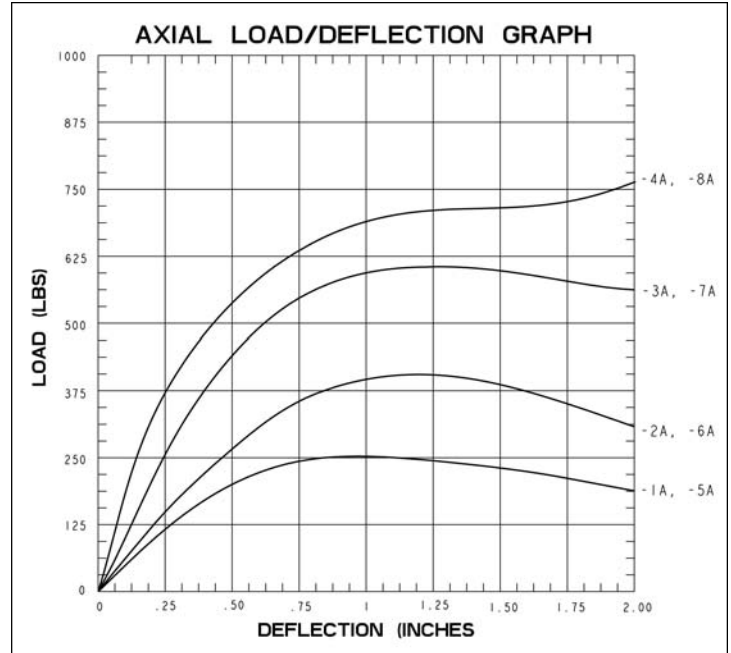
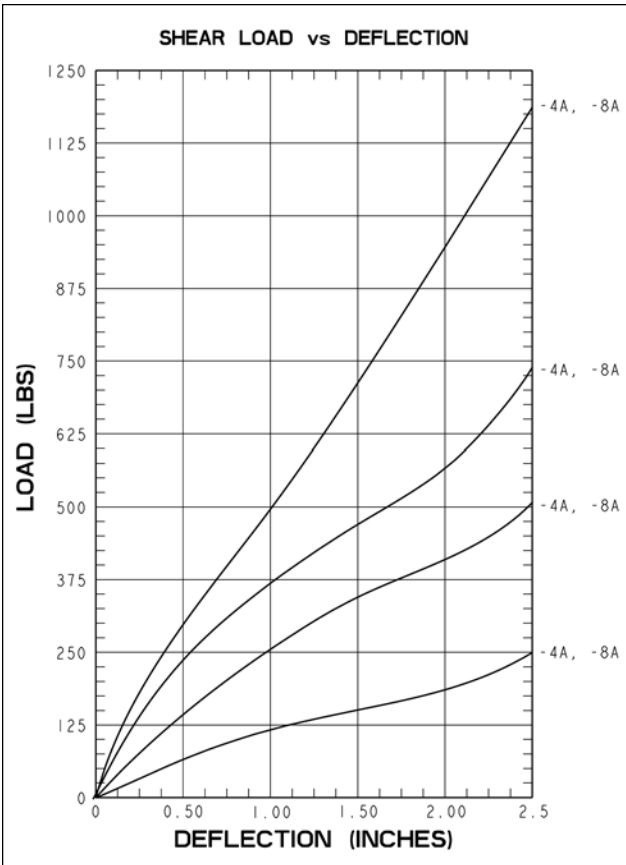

Specifications subject to change without notice. Check with factory for latest revisions. The Federal Trade Commission considers no existing test methods or standards regarding flammability as accurate indicators of the performance of cellular plastic materials under actual fire conditions. Results of existing test methods, such as UL-94, MVSS-302, SAE J-369, and FAR 25.853 are intended only as measurements of the performance of such materials under specific controlled test conditions. Any flammability ratings shown are not intended to reflect hazards presented by these materials under actual fire conditions. The information contained herein is based on laboratory test data developed for PTI and is believed to be reliable, but its accuracy or completeness is not guaranteed. The buyer must test any product to determine the suitability for his specific application before use. PTI DISCLAIMS ANY RESPONSIBILITY FOR: 1) WARRANTIES OF FITNESS AND PURPOSE, 2) VERBAL RECOMMENDATIONS, 3) CONSEQUENTIAL DAMAGES FROM USE AND 4) VIOLATION OF ANY PATENTS OR TRADEMARKS HELD BY OTHERS.