



Attributes

- Fail-safe
- Axial to radial stiffness ratio 1:1
- Compact, low profile design
- Easy to install
- Rugged design

Specifications

- Natural Frequency—8-18 Hertz
- Transmissibility at resonance—10:1
- Resilient Element—Neoprene
- Standard materials—Cold-rolled steel

Elastomeric Data

- Neoprene has an operating temperature range of -40°F to +200°F (-40°C to +93°C) and is resistant to oil, most solvents and ozone
- Other elastomeric formulations are available in BUNA-N, Silicone, Butyl and Polybutadiene for improved damping, low and high temperature resistance

Specifications subject to change without notice. Check with factory for latest revisions. The Federal Trade Commission considers no existing test methods or standards regarding flammability as accurate indicators of the performance of cellular plastic materials under actual fire conditions. Results of existing test methods, such as UL-94, MVSS-302, SAE J-369, and FAR 25.853 are intended only as measurements of the performance of such materials under specific controlled test conditions. Any flammability ratings shown are not intended to reflect hazards presented by these materials under actual fire conditions. The information contained herein is based on laboratory test data developed for PTI and is believed to be reliable, but its accuracy or completeness is not guaranteed. The buyer must test any product to determine the suitability for his specific application before use. PTI DISCLAIMS ANY RESPONSIBILITY FOR: 1) WARRANTIES OF FITNESS AND PURPOSE, 2) VERBAL RECOMMENDATIONS, 3) CONSEQUENTIAL DAMAGES FROM USE AND 4) VIOLATION OF ANY PATENTS OF TRADEMARKS HELD BY OTHERS.

Applications

- Truck, bus and marine
- Generators, HVAC
- Electronics
- Pumps, compressors, blowers

Load range

- 1761 = 5 load ratings to 300 lbs. max.
- 1762 = 5 load ratings to 630 lbs. max.
- 1763 = 5 load ratings to 1330 lbs. max.
- 1764 = 5 load ratings to 2100 lbs. max.
- 1765 = 5 load ratings to 4560 lbs. max

Weights

- 1761 = .10 lbs.
- 1762 = .31 lbs.
- 1763 = .70 lbs.
- 1764 = 1.5 lbs.
- 1765 = 2.8 lbs.



Part #	Thick Plate Thickness (in.)	Axial Load Thick (lbs.)	Radial Load Thick (lbs.)	Axial Natural Frequency (hz)	Bolt Size Grade 5	Max Torque (ft.-lbs.) Dry	Color
		Thick Plate	Thick Plate	Thick Plate			
1761-30	3/8	40	20	15	3/8	30	Red
1761-40	3/8	90	30	15	3/8	30	Orange
1761-50	3/8	140	40	15	3/8	30	Yellow
1761-60	3/8	250	50	15	3/8	30	Green
1761-70	3/8	300	60	15	3/8	30	Blue

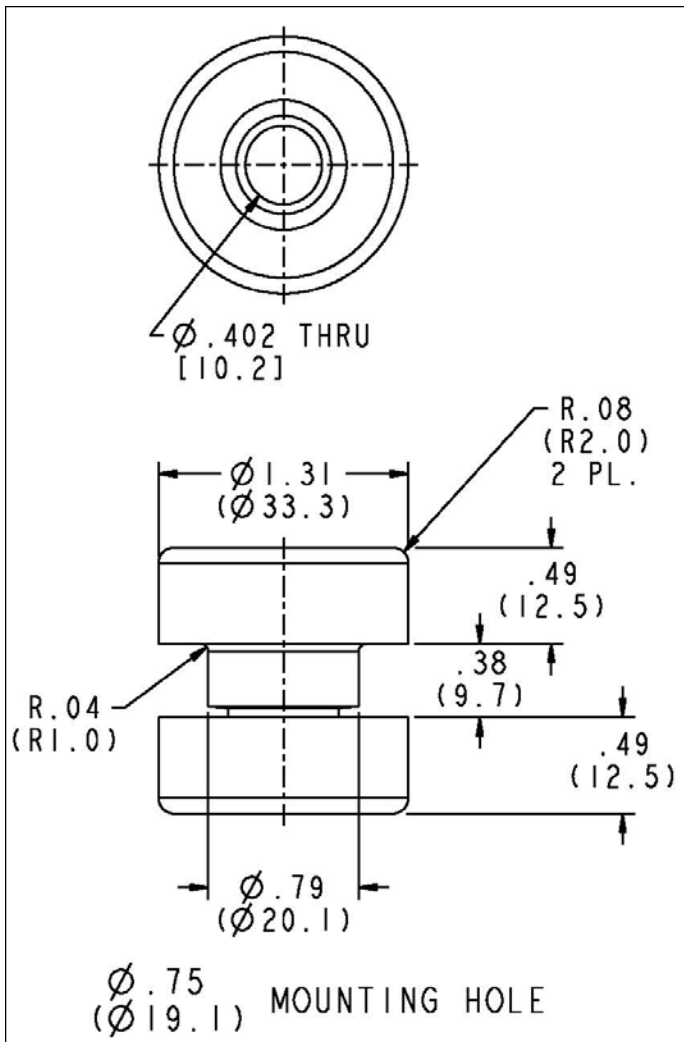

SNUBBING WASHER
P/N SW-1560-0391-0090-SZ
O.D. = $\phi 1.560$ "
I.D. = $\phi .391$ "
THICKNESS = $.090$ "
MATERIAL—1010-1020 CRS
FINISH—CLEAR ZINC

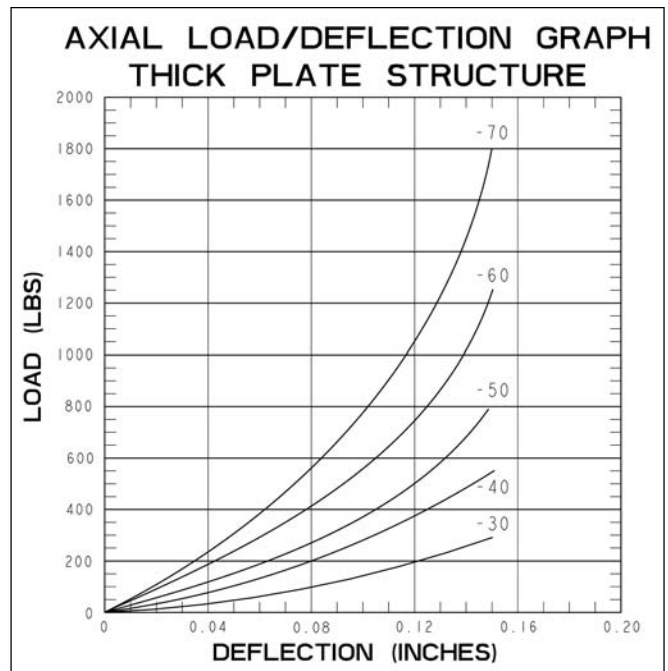

Specifications subject to change without notice. Check with factory for latest revisions. The Federal Trade Commission considers no existing test methods or standards regarding flammability as accurate indicators of the performance of cellular plastic materials under actual fire conditions. Results of existing test methods, such as UL-94, MVSS-302, SAE J-369, and FAR 25.853 are intended only as measurements of the performance of such materials under specific controlled test conditions. Any flammability ratings shown are not intended to reflect hazards presented by these materials under actual fire conditions. The information contained herein is based on laboratory test data developed for PTI and is believed to be reliable, but its accuracy or completeness is not guaranteed. The buyer must test any product to determine the suitability for his specific application before use. PTI DISCLAIMS ANY RESPONSIBILITY FOR: 1) WARRANTIES OF FITNESS AND PURPOSE, 2) VERBAL RECOMMENDATIONS, 3) CONSEQUENTIAL DAMAGES FROM USE AND 4) VIOLATION OF ANY PATENTS OR TRADEMARKS HELD BY OTHERS.



Part #	Mounting Hole Diameter	Mounting Hole Radius	Snubbing Washer Part Number	Snubbing Washer OD	Snubbing Washer ID	Snubbing Washer Thickness
1761	.75	.04	SW 1560-0391-0090-SZ	1.560	.391	.090
1762	1.25	.06	SW-2130-0532-0134-SZ	2.130	.532	.134
1763	1.50	.09	SW-2810-0657-0188-SZ	2.810	.657	.188
1764	2.25	.12	SW-3880-0938-0250-SZ	3.880	.938	.250
1765	2.50	.13	SW-5250-1063-0375-SZ	5.250	1.063	.375

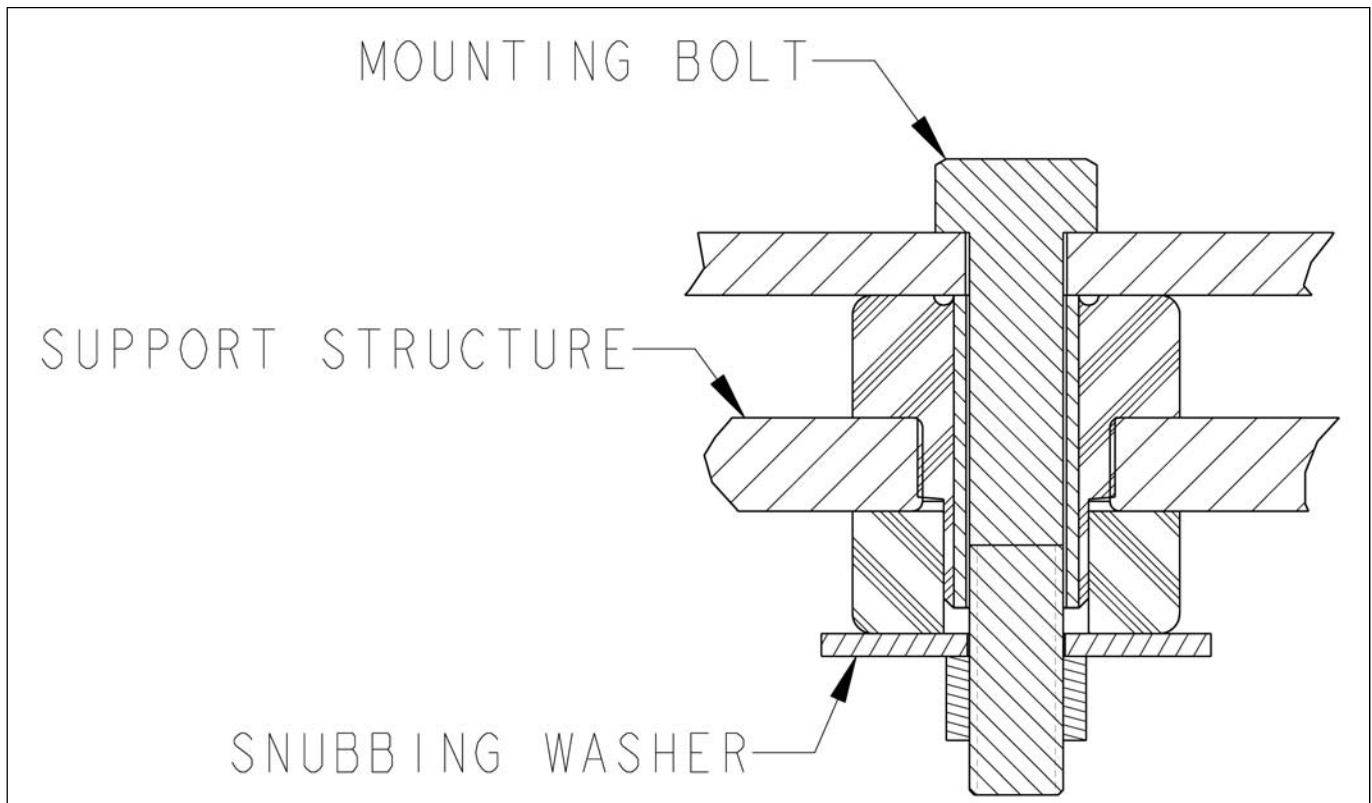

Specifications subject to change without notice. Check with factory for latest revisions. The Federal Trade Commission considers no existing test methods or standards regarding flammability as accurate indicators of the performance of cellular plastic materials under actual fire conditions. Results of existing test methods, such as UL-94, MVSS-302, SAE J-369, and FAR 25.853 are intended only as measurements of the performance of such materials under specific controlled test conditions. Any flammability ratings shown are not intended to reflect hazards presented by these materials under actual fire conditions. The information contained herein is based on laboratory test data developed for PTI and is believed to be reliable, but its accuracy or completeness is not guaranteed. The buyer must test any product to determine the suitability for his specific application before use. PTI DISCLAIMS ANY RESPONSIBILITY FOR: 1) WARRANTIES OF FITNESS AND PURPOSE, 2) VERBAL RECOMMENDATIONS, 3) CONSEQUENTIAL DAMAGES FROM USE AND 4) VIOLATION OF ANY PATENTS OR TRADEMARKS HELD BY OTHERS.