

Load Range

- 1751 = 3 load ratings to 60 lbs.
- 1752 = 3 load ratings to 100 lbs.
- 1753 = 5 load ratings to 220 lbs.
- 1754 = 5 load ratings to 380 lbs.
- 1755 = 5 load ratings to 680 lbs.
- 1756 = 5 load ratings to 1000 lbs.
- 1757 = 5 load ratings to 1780 lbs.

Specifications

- Natural Frequency - 8-18 Hertz
- Transmissibility at resonance - 10:1
- Resilient Element - Neoprene
- Standard materials - Cold-rolled steel
- Standard Finish - Zinc Phosphate, Black Enamel Paint (BP), Electroless Nickel (EN)
- Weight - See dimensional drawings

Elastomeric Data

- Neoprene elastomer has an operating temperature range of -40°F to $+200^{\circ}\text{F}$ (-40°C to $+93^{\circ}\text{C}$) and is resistant to most solvents, oils and ozone.
- Special elastomer and finishes are available for applications in severe environments. Please note that Silicone elastomer is not compatible with nickel plating.

Specifications subject to change without notice. Check with factory for latest revisions. The Federal Trade Commission considers no existing test methods or standards regarding flammability as accurate indicators of the performance of cellular plastic materials under actual fire conditions. Results of existing test methods, such as UL-94, MVSS-302, SAE J-369, and FAR 25.853 are intended only as measurements of the performance of such materials under specific controlled test conditions. Any flammability ratings shown are not intended to reflect hazards presented by these materials under actual fire conditions. The information contained herein is based on laboratory test data developed for PTI and is believed to be reliable, but its accuracy or completeness is not guaranteed. The buyer must test any product to determine the suitability for his specific application before use. PTI DISCLAIMS ANY RESPONSIBILITY FOR: 1) WARRANTIES OF FITNESS AND PURPOSE, 2) VERBAL RECOMMENDATIONS, 3) CONSEQUENTIAL DAMAGES FROM USE AND 4) VIOLATION OF ANY PATENTS OF TRADEMARKS HELD BY OTHERS.

Applications

- Lab equipment
- Business machines
- Vehicle application
- Marine engines
- Power generation
- Cab mounts

Benefits

- Easy to install
- Low cost construction
- Can be mounted in both axial and radial direction

Attributes

- All attitude
- Fail safe design
- Rugged construction
- High fatigue resistance



Part #	Nominal Axial Load (lbs.)	Max. Axial Load (lbs.)	Axial Stiffness at .10" Deflection (lbs./in.)	Radial Static Load Nominal	Radial Static Load Max.	Radial Stiffness at .10" Deflection (lbs./in.)	Transmissibility	Free Height (max. in.)	Resilient Materials	Structural Materials	Finish	Core Style	Center Hole	Flange Hole	Color Code
1757-30	830	1245	8300	415	830	4150	10:1	4.00	Neoprene	Steel	Zinc	Thru Hole	1.062	.656	Red
1757-40	1000	1500	10000	500	1000	5000	10:1	4.00	Neoprene	Steel	Zinc	Thru Hole	1.062	.656	Orange
1757-50	1210	1815	12100	605	1210	6050	10:1	4.00	Neoprene	Steel	Zinc	Thru Hole	1.062	.656	Yellow
1757-60	1470	2205	14700	735	1470	7350	10:1	4.00	Neoprene	Steel	Zinc	Thru Hole	1.062	.656	Green
1757-70	1780	2700	17800	890	1780	8900	10:1	4.00	Neoprene	Steel	Zinc	Thru Hole	1.062	.656	Blue
1757-30BP	830	1245	8300	415	830	4150	10:1	4.00	Neoprene	Steel	Black Paint	Thru Hole	1.062	.656	Red
1757-40BP	1000	1500	10000	500	1000	5000	10:1	4.00	Neoprene	Steel	Black Paint	Thru Hole	1.062	.656	Orange
1757-50BP	1210	1815	12100	605	1210	6050	10:1	4.00	Neoprene	Steel	Black Paint	Thru Hole	1.062	.656	Yellow
1757-60BP	1470	2205	14700	735	1470	7350	10:1	4.00	Neoprene	Steel	Black Paint	Thru Hole	1.062	.656	Green
1757-70BP	1780	2700	17800	890	1780	8900	10:1	4.00	Neoprene	Steel	Black Paint	Thru Hole	1.062	.656	Blue
1757-30EN	830	1245	8300	415	830	4150	10:1	4.00	Neoprene	Steel	Electroless Nickel	Thru Hole	1.062	.656	Red
1757-40EN	1000	1500	10000	500	1000	5000	10:1	4.00	Neoprene	Steel	Electroless Nickel	Thru Hole	1.062	.656	Orange
1757-50EN	1210	1815	12100	605	1210	6050	10:1	4.00	Neoprene	Steel	Electroless Nickel	Thru Hole	1.062	.656	Yellow
1757-60EN	1470	2205	14700	735	1470	7350	10:1	4.00	Neoprene	Steel	Electroless Nickel	Thru Hole	1.062	.656	Green
1757-70EN	1780	2700	17800	890	1780	8900	10:1	4.00	Neoprene	Steel	Electroless Nickel	Thru Hole	1.062	.656	Blue

Specifications subject to change without notice. Check with factory for latest revisions. The Federal Trade Commission considers no existing test methods or standards regarding flammability as accurate indicators of the performance of cellular plastic materials under actual fire conditions. Results of existing test methods, such as UL-94, MVSS-302, SAE J-369, and FAR 25.853 are intended only as measurements of the performance of such materials under specific controlled test conditions. Any flammability ratings shown are not intended to reflect hazards presented by these materials under actual fire conditions. The information contained herein is based on laboratory test data developed for PTI and is believed to be reliable, but its accuracy or completeness is not guaranteed. The buyer must test any product to determine the suitability for his specific application before use. PTI DISCLAIMS ANY RESPONSIBILITY FOR: 1) WARRANTIES OF FITNESS AND PURPOSE, 2) VERBAL RECOMMENDATIONS, 3) CONSEQUENTIAL DAMAGES FROM USE AND 4) VIOLATION OF ANY PATENTS OF TRADEMARKS HELD BY OTHERS.

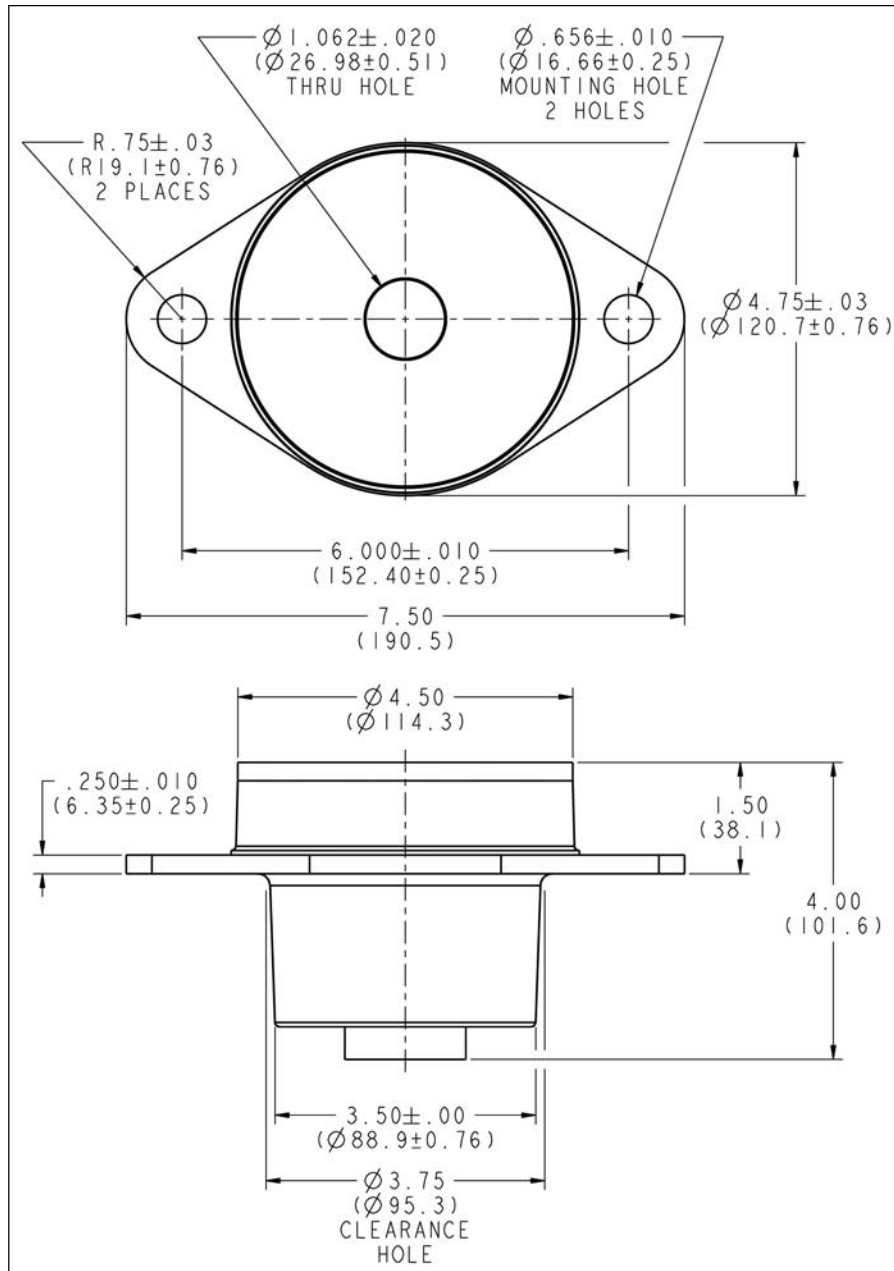

Specifications subject to change without notice. Check with factory for latest revisions. The Federal Trade Commission considers no existing test methods or standards regarding flammability as accurate indicators of the performance of cellular plastic materials under actual fire conditions. Results of existing test methods, such as UL-94, MVSS-302, SAE J-369, and FAR 25.853 are intended only as measurements of the performance of such materials under specific controlled test conditions. Any flammability ratings shown are not intended to reflect hazards presented by these materials under actual fire conditions. The information contained herein is based on laboratory test data developed for PTI and is believed to be reliable, but its accuracy or completeness is not guaranteed. The buyer must test any product to determine the suitability for his specific application before use. PTI DISCLAIMS ANY RESPONSIBILITY FOR: 1) WARRANTIES OF FITNESS AND PURPOSE, 2) VERBAL RECOMMENDATIONS, 3) CONSEQUENTIAL DAMAGES FROM USE AND 4) VIOLATION OF ANY PATENTS OR TRADEMARKS HELD BY OTHERS.

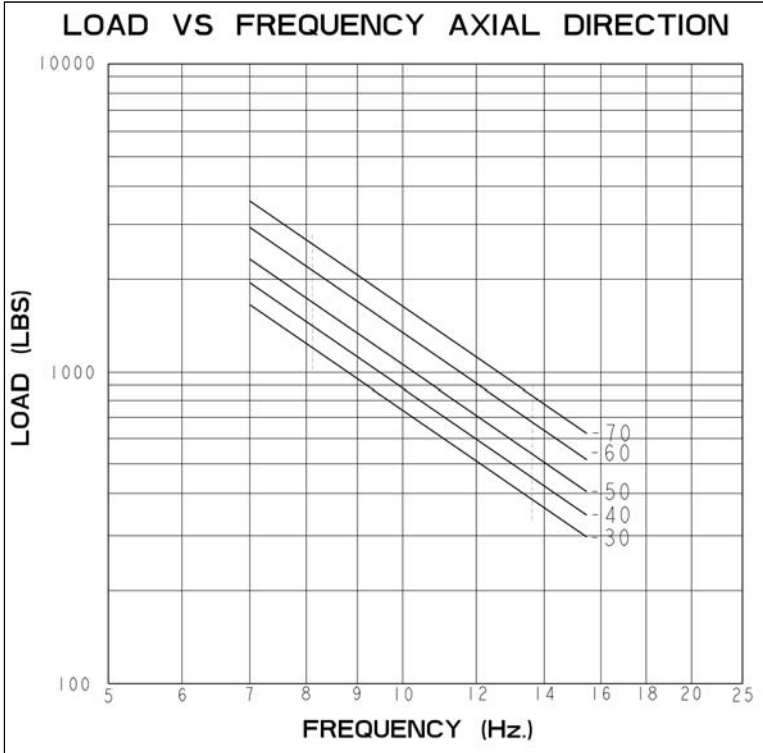

SNUBBING WASHER
P/N SW-3250-1010-0250-SZ
O.D. = Ø 3.25"
I.D. = Ø 1.01"
THICKNESS = .250"
MATERIAL—1010-1020 CRS
FINISH—CLEAR ZINC

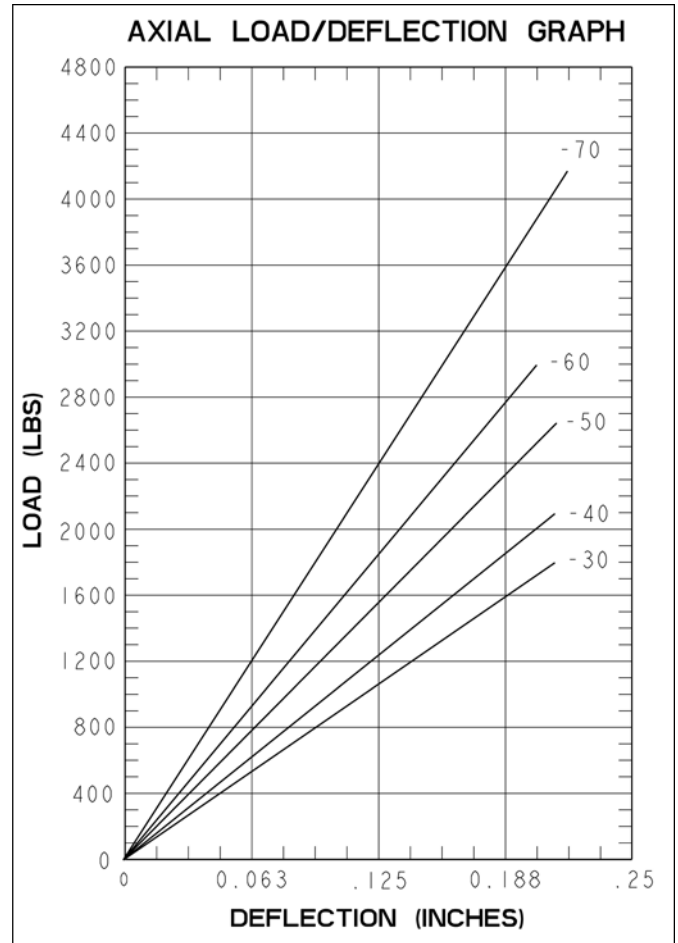

Specifications subject to change without notice. Check with factory for latest revisions. The Federal Trade Commission considers no existing test methods or standards regarding flammability as accurate indicators of the performance of cellular plastic materials under actual fire conditions. Results of existing test methods, such as UL-94, MVSS-302, SAE J-369, and FAR 25.853 are intended only as measurements of the performance of such materials under specific controlled test conditions. Any flammability ratings shown are not intended to reflect hazards presented by these materials under actual fire conditions. The information contained herein is based on laboratory test data developed for PTI and is believed to be reliable, but its accuracy or completeness is not guaranteed. The buyer must test any product to determine the suitability for his specific application before use. PTI DISCLAIMS ANY RESPONSIBILITY FOR: 1) WARRANTIES OF FITNESS AND PURPOSE, 2) VERBAL RECOMMENDATIONS, 3) CONSEQUENTIAL DAMAGES FROM USE AND 4) VIOLATION OF ANY PATENTS OR TRADEMARKS HELD BY OTHERS.