

Polybond North America Inc

Experts in Vibration Isolation

Elastomeric Solutions



DuraFlex[®] Rubber

Damping Materials

Rubber Bonded to Metal

Shock & Vibration Isolators

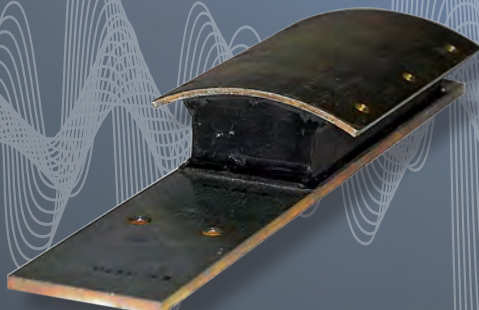
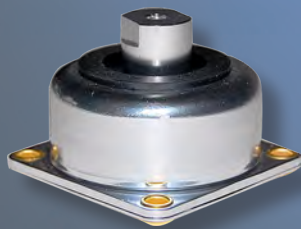

Polybond North America, Inc.

76 Astor Avenue, Bldg. 101 • Norwood, MA 02062

1-781-762-3913 • www.polybondna.com

sales@polybondna.com

Polybond North America, Inc

The Specialist in Custom Shock and Vibration Solutions

Our Company

Polybond North America, Inc., a subsidiary of Polybond India, Pvt, Ltd, began as Engineered Plastic Solutions, Inc. in 1993 by experienced vibration isolation engineers. Based in Norwood MA with a global manufacturing footprint, Polybond North America, Inc. is an engineering and manufacturing company specializing in shock and vibration energy isolation and engineered molded rubber components.

We are devoted to providing not only high quality vibration isolation products, but also incredible customer service and collaboration. By integrating high quality base materials, extensive product development, comprehensive materials testing, and customer collaboration, we are able to provide the most innovative and unique vibration solutions in a variety of applications including industrial, commercial vehicle, electronics, medical and defense industries. Polybond North America, Inc. is always at the forefront of innovation with our engineers developing high quality, custom shock & vibration isolation materials at our Norwood MA technical center.

We have been integral in the design and development of Duraflex®, a proprietary rubber compound. Duraflex® is an ultra-high fatigue-life rubber that exhibits high abrasion resistance, high tensile strength, and excellent bond strength to metal, making it the perfect rubber compound to use in industrial tires, trucking applications, engine mounts, and even military equipment. To add to its value, DuraFlex® also obtained the lowest temperature rise known to exist on the Goodrich Flexometer Test, a milestone that no other manufacturer has been able to obtain and something our engineers pride themselves upon.

For more information about how DuraFlex® Rubber or any of our other custom solutions can be used in your application, please contact our sales team at sales@polybondna.com

PRODUCT SECTIONS

	ALL ELASTOMER ISOLATORS	A
		B
	CENTER BOND SERIES	C
	CUP STYLE MOUNT SERIES	D
	CYLINDRICAL MOUNT SERIES	E
	DAMPING MATERIALS	F
	DOME MOUNT SERIES	G
	FAIL-SAFE COMPRESSION MOUNT SERIES	H
	FLUID MOUNT SERIES	I
	FRICTION STYLE MOUNT SERIES	J
	HIGH DEFLECTION MOUNT SERIES	K
	LOW PROFILE MOUNT SERIES	L
	PLATFORM SERIES	M
	RING AND BUSHING MOUNT SERIES	N
	CAN STYLE MOUNT SERIES	O
	AIR MOUNT SERIES	P
	CUSHYFLEX MOUNT SERIES	Q
	SANDWICH MOUNT SERIES	R
	ARMORFLEX™ MOUNT SERIES	S

TABLE OF CONTENTS

Isolator Selection Guide

Engineering Guide

Property Matrix

SECTION A

All Elastomer Isolators

Ring and Bushing A1-A5

Ball Mount Series A6-A8

SECTION B

INTENTIONALLY
LEFT BLANK

SECTION C

Center Bond Series

EP2000 Series C1-C3

SECTION D

Cup Style Mount Series

Size 0 Cupmount	D1-D5
Size 1 Cupmount	D6-D9
Size 2 Cupmount	D10-D13
Size 3 Cupmount	D14-D17
Size 4 Cupmount	D18-D21

SECTION E

Cylindrical Mount Series

Cylindrical Mounts E1-E20

SECTION F

Damping Materials

Damping Materials F1-F4

SECTION G

Dome Mount Series

Dome Mounts G1-G2

SECTION H

Fail-Safe Compression Mount Series

1751-1757 Series	H1-H22
1804/1805 Series	H23-H27

SECTION I

Fluid Mount Series

1962 Series	I1-I3
1969 Series	I4-I7
2006 Series	I8-I10

SECTION J

Friction Style Mount Series

1772/1773	J1-J3
1900/1901/1902	J4-J9

SECTION K

High Deflection Mount Series

1774/1775 Mount	K1-K5
1824/1829 Dome Mount	K6-K11
1825 Mount Series	K12-K14
1975 Arch Mount	K15-K17

TABLE OF CONTENTS

SECTION L

Low Profile Mount Series

1830/1831 Series	L1-L5
SEM100/500 Series	L6-L10

SECTION M

Platform Mount Series

EP3001-EP3004 Series	M1-M5
EP3106 Series	M6
EP3156 Series	M7
EP3011/EP3020 Series	M8

SECTION N

Ring and Bushing Mount Series

Size 1 Ring and Bushing Mount	N1-N2
Size 2 Ring and Bushing Mount	N3-N4
Size 3 Ring and Bushing Mount	N5-N6
Size 4 Ring and Bushing Mount	N7-N8
Size 5 Ring and Bushing Mount	N9-N10
R&B Installation Drawing	N11
Bushing Series—2061-2065	N12-N16

SECTION O

Can-Style Mount Series

1766 Series	O1-O3
1767 Series	O4-O5
1769 Series	O6-O7

SECTION P

Air Mount Series

English Air Isolator	P1-P2
Metric Air Isolator	P3-P4

SECTION Q

CushyFlex Mount Series

2182 Series	Q1-Q4
2183 Series	Q5-Q7
2184 Series	Q8-Q10

SECTION R

Sandwich Mount Series

2205 Series	R1-R3
2206 Series	R4-R5
2207 Series	R6-R7

SECTION S

ArmorFlex™ Mount Series

2131-2133 Series	S1-S7
2189	S8-S9
2191	S10-S11
2193	S12-S13
2197	S14-S15
2199	S16-S17
2201	S18-S19
2202	S20-S21

ENGINEERING GUIDE

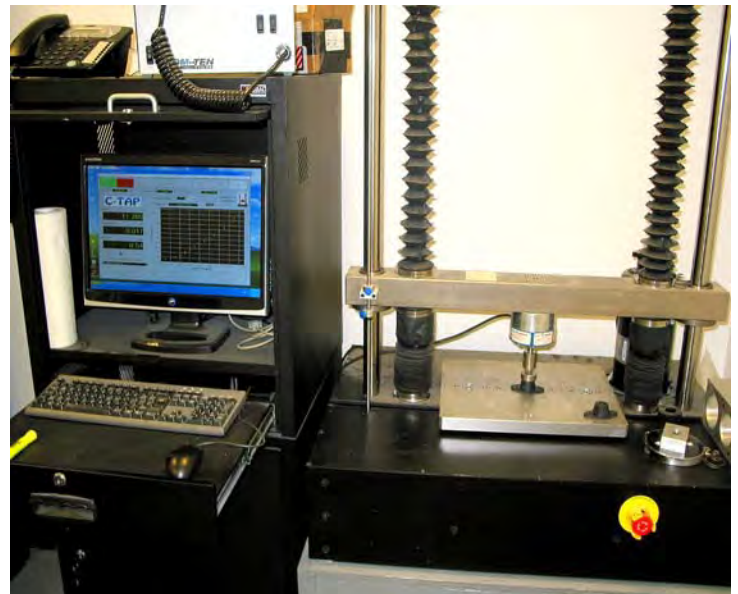
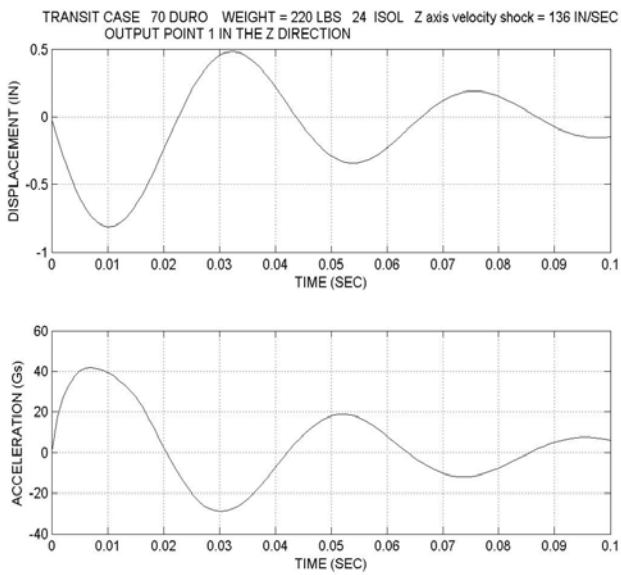
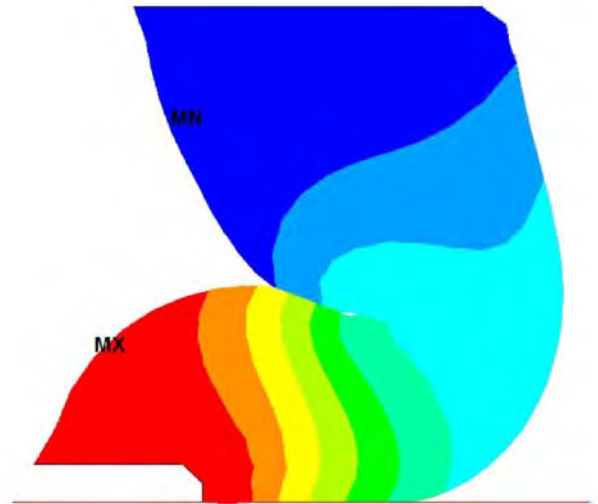
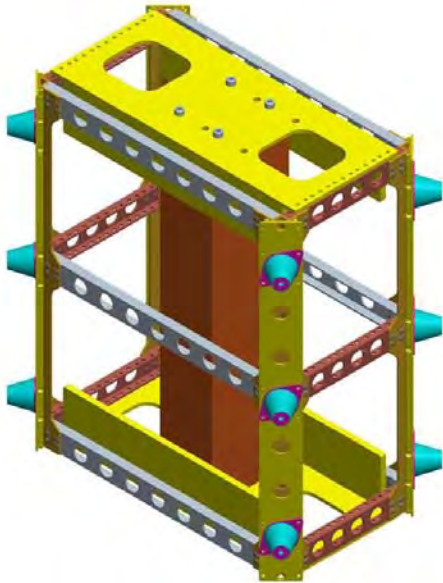

Engineering Guide

Introduction

Mechanical vibrations and shock are present in peoples everyday life. These disturbances can range from small office vibrations to heavy ballistic shock and the adverse effect of this disturbance depend on the fragility level of the equipment.

These vibration environments can range in levels from simple foot traffic in an office environment or heavy seismic disturbances that can effect sensitive equipment such microchip equipment etching, where any adverse vibration can effect the accuracy of the machine.

Other external vibration produced by vehicles, trucks, trains, air conditioners, generators, pumps, etc., can cause adverse responses in sensitive machinery or equipment and produce negative or erroneous results.

In the office environment disturbances from fans and AC units can transmit noise and vibrations to the surrounding structure and produce an unhealthy level of noise and fatigue in the work environment.

Non stationary products subject equipment to much higher shock and vibration that stationary applications. Vibrations from engines, pumps and equipment are present in air, sea and on the road as well as shock and vibration effects from the medium they travel on.

Some of the disturbances from rough roads, impart severe transients shock and vibration to the vehicles traveling on them. In addition to rough seas, naval ships are also subjected to very severe mechanical shock from depth charges and other explosions.

Disturbance elimination techniques from shock and vibration isolators have been designed to provide protection to all types of equipment.

Three main elements:

1. The equipment that needs to be isolated.
2. The support structure that connect the isolator to the equipment.
3. The resilient member or the vibration and shock isolator.

If the equipment is the source of the vibration or shock, the isolator should be designed to reduce the force transmitted from the equipment to the support structure. This is illustrated in **Figure 1**, where M represents the mass of equipment, which is the vibrating source, and K is the spring or isolator, which is located between the mass and the support structure,

If the support structure is the source of the vibration or shock, the purpose of the isolator is to reduce the disturbance transmitted from the support structure to the equipment. An example would be protecting delicate measuring instruments from vibrating floors. This illustrated in **Figure 2**, where M represents the mass of a instrument which is protected by the isolator K from a vibrating floor.

In each case, the principle of isolation is the same. The isolator, a resilient element, stores the incoming energy like a spring based on a discreet time interval like a (dashpot) which reduces the disturbance to the equipment or support structure.

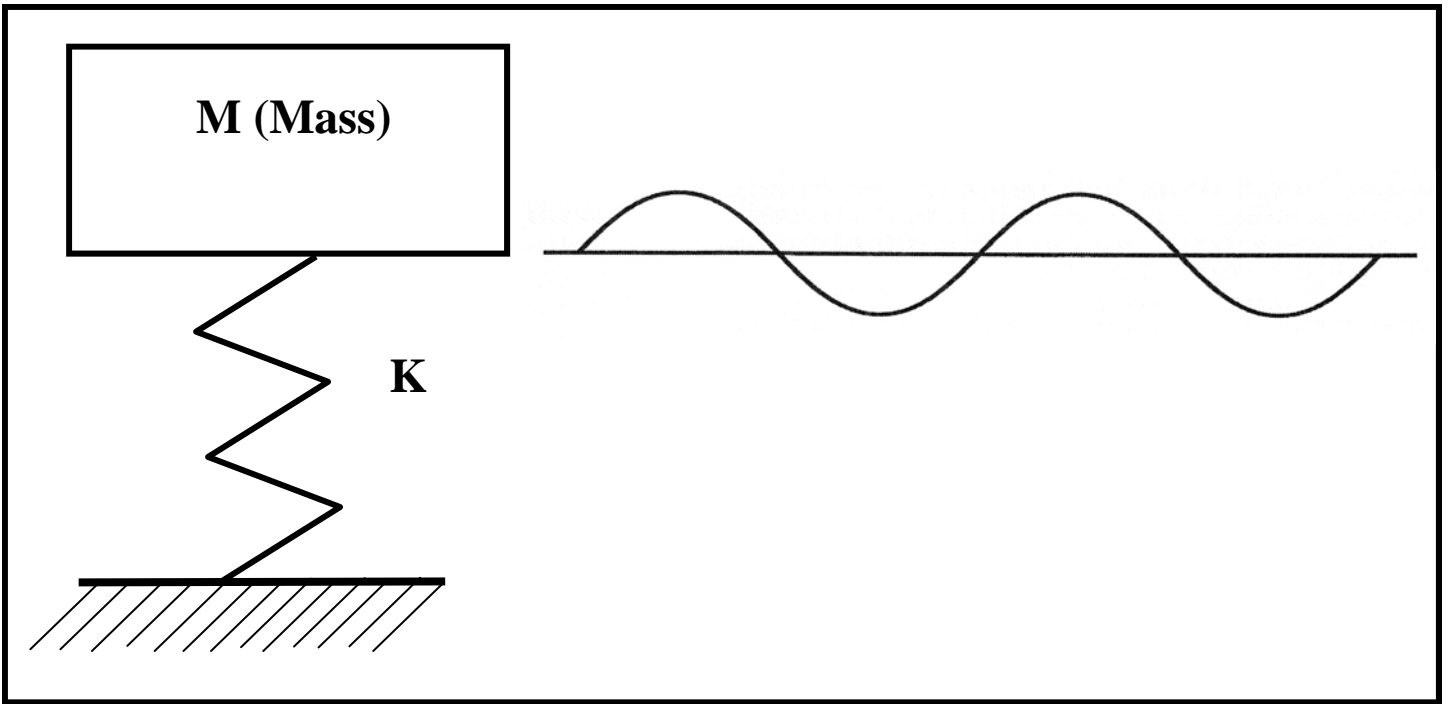

Figure 1. Schematic of a single degree of freedom dynamic system where the mass, M , is the vibratory source.

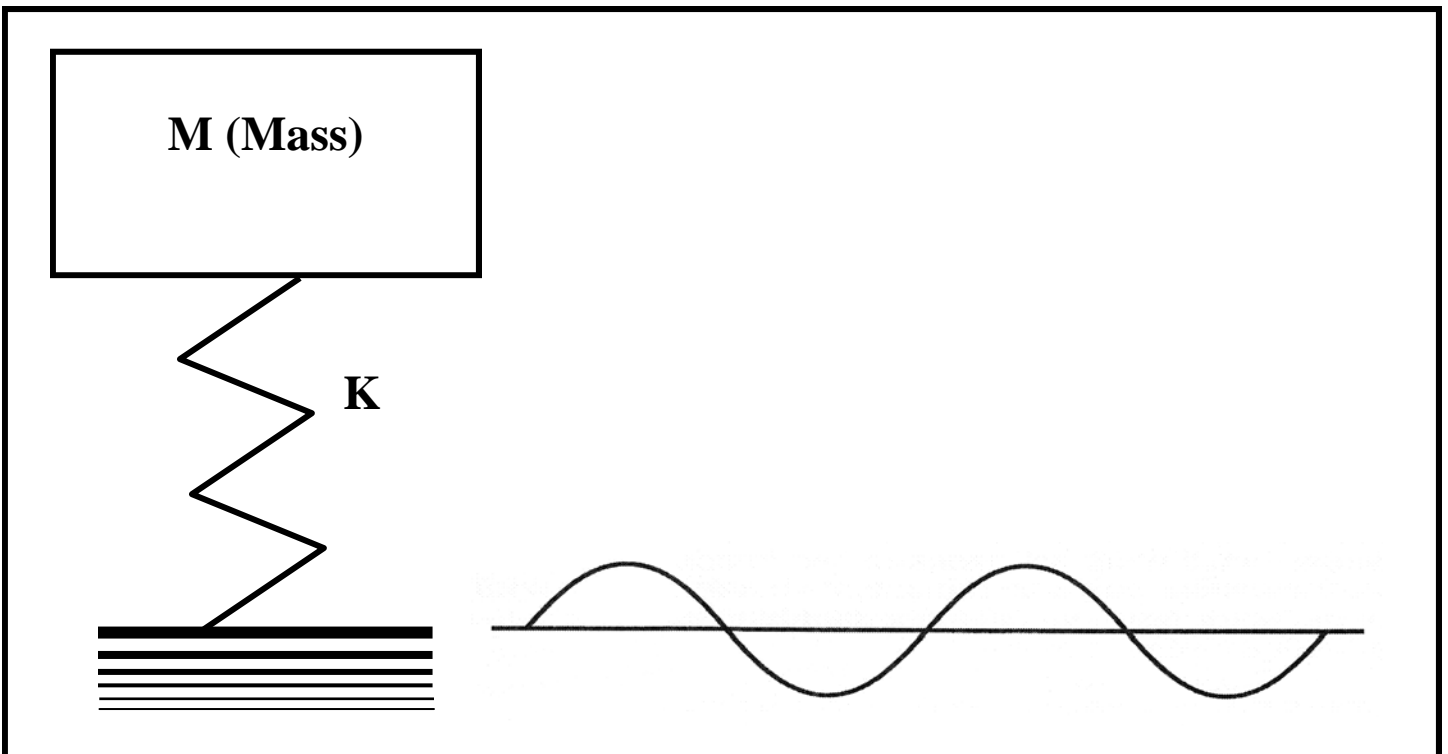

Figure 2. Schematic of a single degree of freedom dynamic system where the floor is the vibratory source.

TERMS AND DEFINITIONS

In order to fully understand vibration and shock theory there are a number of terms and definitions that should be understood. The terms and definitions are basic and easily understood to maximize the effectiveness of this engineering guide.

A vibration isolator and a shock isolator are not always mutually exclusive, but for the purposes of analysis must be treated separately. For all practical purposes the environmental conditions will dictate the design of the isolator. A heavy shock will more than likely have a different design than an office vibration environment.

Before any selection of a vibration or shock isolator can be made, the engineer should have a basic understanding of the following definitions, terms and equations:

VIBRATION

A magnitude (force, displacement, or acceleration) which oscillates about some specified reference where the magnitude of the force, displacement, or acceleration is alternately smaller and greater than the reference. Vibration is commonly expressed in terms of frequency (cycles per second or Hz) and amplitude, which is the magnitude of the force, displacement, or acceleration. The relationship of these terms is illustrated in **Figure 3**.

FREQUENCY

Frequency may be defined as the number of complete cycles of oscillations which occur per unit of time.

$$\text{Frequency} = f = \frac{\text{cycles}}{\text{second}} (\text{cps}) = \text{Hertz (Hz)}$$

PERIOD

The time required to complete one cycle of vibration.

$$\text{Period} = \lambda = \frac{1}{f}$$

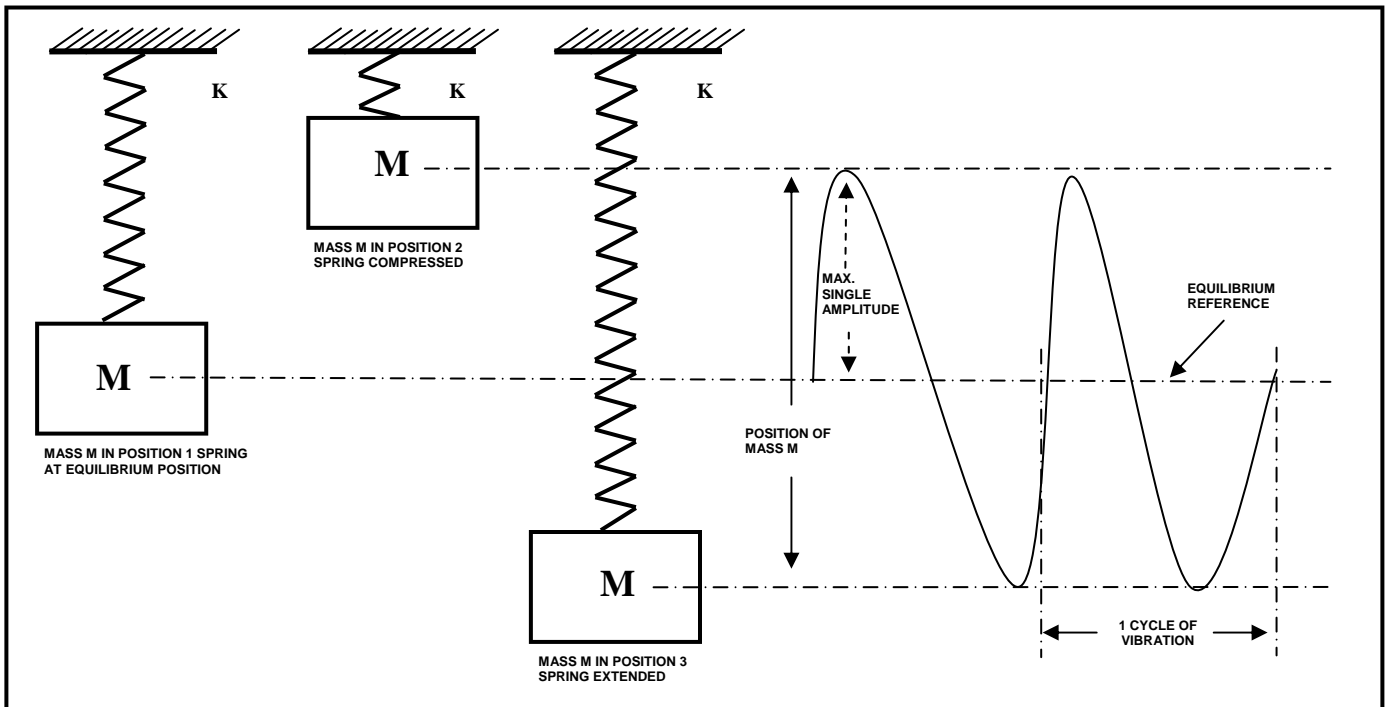

Figure 3. A Schematic of oscillating spring mass system and vibratory responses.

FORCING FREQUENCY

The number of oscillations per unit time of a force or displacement applied to a system.

$$\text{Forcing Frequency} = f_d$$

NATURAL FREQUENCY

Natural frequency may be defined as the number of oscillations that a system will carry out per unit time if displaced from its equilibrium position and allowed to vibrate freely. Where K is the spring stiffness and M is the mass and W is the weight. (See Figure 3)

$$f_n = \frac{1}{2\pi} \sqrt{\frac{K}{M}} \quad \text{Eq.1}$$

$$f_n = \frac{1}{2\pi} \sqrt{\frac{Kg}{W}} \quad \text{Eq.2}$$

$$f_n = 3.13 \sqrt{\frac{K}{W}} \quad \text{Eq.3}$$

Natural frequency in terms of static deflection ΔS :

$$f_n = 3.13 \sqrt{\frac{1}{\Delta s}} \quad \text{Eq.4}$$

Equations 1 through 4 all neglect the effects of damping. When damping is considered, Equation 2 becomes where C/CC is damping ratio which is specific to the material or structure of damping being used:

$$f_n = \frac{1}{2\pi} \sqrt{\frac{Kg}{W} \left[1 - \left(\frac{C}{C_c} \right)^2 \right]} \quad \text{Eq.5}$$

AMPLITUDE

The amplitude of a sinusoidal vibration as displacement, velocity, or acceleration is the zero to peak value corresponding to the maximum value of a vibration time-history. (See Figure 3).

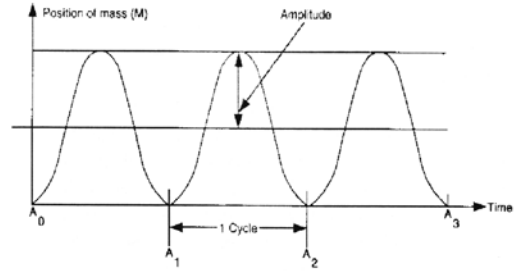

DISPLACEMENT

Displacement is an amount of movement that specifies the change of the position of a body to an equilibrium position.

VELOCITY

Velocity is a time rate of change of displacement with respect to a frame of reference.

ACCELERATION

Acceleration is a time rate of change of velocity with respect to a frame of reference. These values of acceleration changed with both latitude and elevation based on the point of reference. These values are measured in G 's = 386 In/Sec^2 , 32 Ft/Sec^2 or 9.8 M/Sec^2 which is the standard measured used for the acceleration due to gravity.

DEFLECTION

Deflection is the distance an elastic body or spring will move when subjected to a force, F.

SPRING STIFFNESS

The ratio of the force applied divided by the distance or deflection traveled.

$$K = \frac{\text{Force}}{\text{Deflection}} = \frac{\text{lb}}{\text{in}} \text{ Eq.6}$$

ELASTIC CENTER

The elastic center is defined as a single point at which the stiffness of an isolator or series of isolators can be represented by a single stiffness value.

COMPRESSION

A deformation caused by squeezing the layers of an object in a direction perpendicular to the layers.

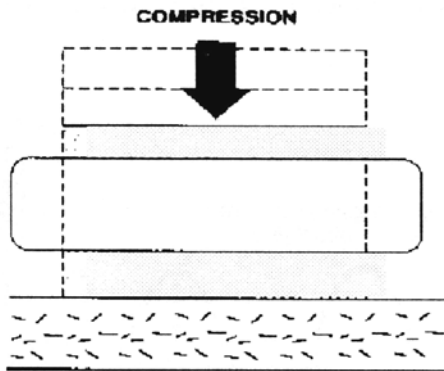

DAMPING

Damping is when energy is dissipated in a vibratory system. There are three types of damping generally encountered: coulomb, hysteresis and viscous.

COULOMB DAMPING

If the damping force is constant and is independent of the velocity of the system, the system is said to have coulomb damping.

HYSTERESIS (Material) DAMPING

Damping which results from the molecular motion of the structure of a material when that material is subjected to a velocity is referred to as hysteresis damping. Elastomers are examples this type of damping.

VISCOUS DAMPING

If a particle encounters a force which its magnitude is proportional to the magnitude of the velocity of that particle in an opposite direction, the particle is said to be viscously damped. This is the easiest type of damping to model mathematically. All of the equations in this text book via a dashpot are based on use of a viscous damping coefficient.

DAMPING COEFFICIENT

Damping for material is expressed by its damping coefficient.

$$\text{Damping coeff.} = C = \frac{\text{lb. sec}}{\text{in}}$$

CRITICAL DAMPING

A system is critically damped when it is displaced from its original position and returns to its initial static position without any rebounding. The damping coefficient for critical damping can be calculated using:

$$C_c = 2\sqrt{KM} \quad \text{Eq.7}$$

DAMPING FACTOR

The non-dimensionless ratio which defines the amount of damping in a system.

$$\text{Damping factor} = \frac{C}{C_c} = \zeta$$

DUROMETER (HARDNESS)

A numerical value which measures the resistance to the penetration of the durometer meter indenter point; value may be taken immediately or after a very short specified time.

FRAGILITY

Is the highest level vibration or shock that a system can stand without any equipment failure.

“G” LEVEL

A dimensionless value of the shock acceleration level divided the acceleration due to gravity.

ISOLATION

The protection of equipment from vibration or shock. The percentage of isolation required is a function of the fragility of the equipment.

LOAD DEFLECTION CURVE

The measured and recorded displacement of a mounting plotted versus an applied load.

RANDOM VIBRATION

Non-sinusoidal vibration characterized by the excitation of a broad band of frequencies at random levels simultaneously.

RESONANCE

When the forcing frequency equals the natural frequency of a system, this condition is known as resonance.

SET

Is the amount of permanent deformation that is never recovered after removal of a load. It may be in shear or compression.

SHEAR

A deformation caused by sliding layers of an object past each other in a direction parallel to the layers.

TRANSMISSIBILITY

Defined as the ratio of the dynamic output to the dynamic input.

$$T = \frac{\sqrt{1 + \left(2 \frac{f_d}{f_n} \cdot \frac{C}{C_c}\right)^2}}{\sqrt{\left(1 - \frac{f_d^2}{f_n^2}\right)^2 + \left(2 \frac{f_d}{f_n} \cdot \frac{C}{C_c}\right)^2}} \quad \text{Eq.8}$$

For negligible damping ($C/C_c=0$), T becomes:

$$T = \left| \frac{1}{1 - \left(\frac{f_d}{f_n}\right)^2} \right| \quad \text{Eq.9}$$

When resonance occurs, $f_d/f_n=1$ and $C/C_c=$ any value, T is at its max and Equation 8 becomes:

$$T_{\max} = \frac{1}{2 \frac{C}{C_c}} \quad \text{Eq.10}$$

SHOCK

Movement in which there is a sharp and abrupt change in velocity. Examples of this are an explosion or a package falling to the ground.

SHOCK PULSE

A shock pulse is the transmission of kinetic energy to a system which happens in a very short time. This pulse is then followed by a natural decay in motion. Shock pulses are normally displayed graphically as acceleration vs. time curves. **See Figure 11**

SHOCK TRANSMISSION

This can be calculated with the following equation:

$$\begin{aligned} \text{Shock transmittance } d &= G_T \\ G_T &= \frac{V(2\pi f_n)}{386} = \frac{V(f_n)}{61.4} \end{aligned} \quad \text{Eq.11}$$

In this equation, V is the instantaneous velocity of the shock and f_n is the natural frequency of the system.

The dynamic linear deflection of an isolator under the shock pulse can be determined by the use of the following equation:

$$\Delta_D = \frac{V}{2\pi f_n} \quad \text{Eq.12}$$

Design Considerations

VERTICAL VIBRATION

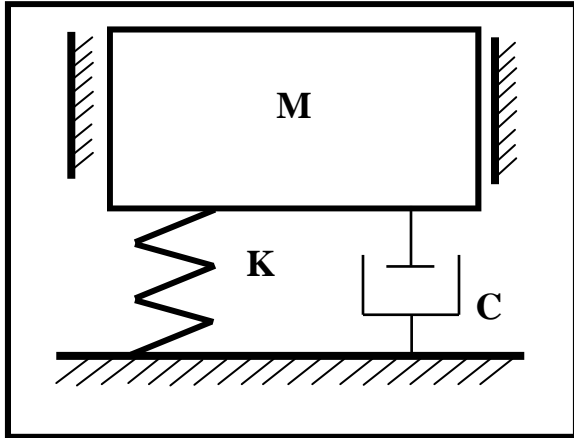

Figure 4. Schematic of the simplest form of an isolator, a spring, K , and a viscous damper, C , supporting the equipment mass, M .

The isolator may be best understood by first reducing it to its simplest form. The system of **Figure 4** includes a rigid body mass M supported by a spring K that is constrained to move only in vertical direction without any rotation. A dashpot C is arranged in parallel with the spring between the support and the mass. The mounted equipment is represented by the mass M , while the spring and dashpot represent the visco-elastic properties of a conventional isolator. The simple system shown in **Figure 4** is said to be a single-degree-of-freedom system because it can only move in a positive or negative vertical direction.

Isolation is maintained by the proper relationship between the disturbing frequency and the system's natural frequency. The natural frequency, or more properly, the natural frequency of the system consists of isolator and mounted equipment.

$$f_n = \frac{1}{2\pi} \sqrt{\frac{Kg}{W} \left[1 - \left(\frac{C}{Cc} \right)^2 \right]} \quad (\text{Eq.6})$$

A critical damped system returns to its original position without any oscillation if displaced; it has no natural frequency, $C=C_c$ in **Equation 6**.

In most real life circumstances the value of the damping coefficient C is relatively small. The influence of damping on the natural frequency may then be neglected. Setting the damping coefficient C equal to zero, the system becomes an undamped single-degree-of-freedom system, and the undamped natural frequency given by:

$$f_n = \frac{1}{2\pi} \sqrt{\frac{Kg}{W}} \quad (\text{Eq.2})$$

Static deflection often is used to define the characteristics of an isolator. Static deflection is the deflection of the isolator under the static load of the mounted equipment.

Referring to **Equation 2** and substituting $g = 386 \text{ in/sec}^2$, $W/K = \Delta_s$, the following expression is obtained for natural frequency in terms of static deflection:

$$f_n = 3.13 \sqrt{\frac{1}{\Delta_s}} \quad (\text{Eq.4})$$

A graphic portrayal of **Equation 4** is given in **Figure 5**. It thus appears possible to determine the natural frequency of a single-degree-of-freedom system by measuring only the static deflection.

This is true under two circumstances

- 1) The spring must have a linear load vs. deflection curve.
- 2) The static to dynamic stiffing factor must be one. The isolator must have the same stiffness statically as it does dynamically.

The dynamic modulus of elasticity of elastomeric materials is higher than the static modulus. Since the modulus is higher dynamically the natural frequency of the isolator is thus somewhat greater than that calculated on the basis of the static deflection alone.

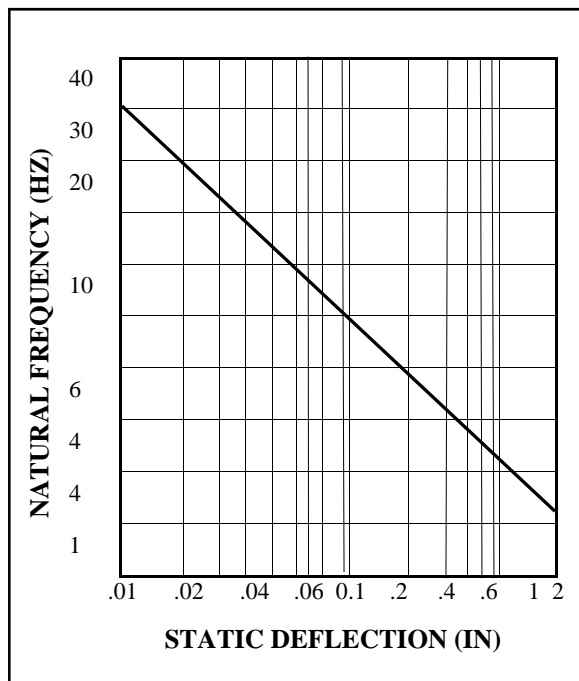

Figure 5. Graph of the natural frequency and static deflection of a linear, single-degree-of-freedom system.

The dynamic stiffness and natural frequency may be determined when the isolator is vibrated based on a known load and calculating the dynamic stiffness from Equation 2.

The efficiency of isolators in reducing vibration is indicated by the transmissibility of the system. Figure 6 illustrates a typical transmissibility curve for an equipment of weight W supported on an isolator with stiffness K and damping coefficient C which is subjected to a vibration disturbance of frequency f_d . When the system is excited at its natural frequency, the system will be in resonance and the disturbance forces will be amplified rather than reduced. Therefore, it is very desirable to select the proper isolator so that its natural frequency will be excited as little as possible in service and will not coincide with any critical frequencies of the equipment.

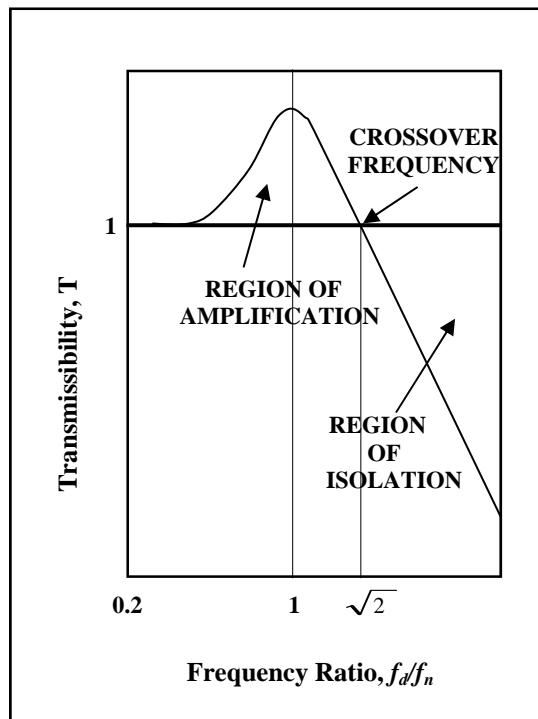

Figure 6. Transmissibility curve for an isolated system where f_d = disturbing frequency and f_n = system natural frequency.

In Figure 6, when the ratio of the disturbing frequency f_d over the natural frequency f_n is less than $\sqrt{2}$ then the transmissibility is greater than 1, or the equipment experiences amplification.

$$f_d / f_n \leq \sqrt{2}, T \geq 1$$

isolation begins when:

$$f_d / f_n = \sqrt{2} \text{ (at this point } T = 1)$$

$$f_d / f_n > \sqrt{2}, T < 1$$

DAMPING

The majority of isolators have varying degrees of damping levels depending on the material used and the construction of the isolator. **Table 1** shows the various levels of damping factor C/C_c in different materials. Damping is important when the isolation system is operating near resonance because it helps to reduce transmissibility. An air compressor mounted on steel springs which possess very little damping, upon start up and shut down the disturbing frequency of the compressor will at some point correspond with the natural frequency of the spring-mass system. With lightly damped system, the forces from the compressor to the support will be very large and the transmissibility will be very high. If an elastomeric isolator which has a higher degree of damping, amplification at resonance would be much less, but there are always trade off.

Material	Approx. Damping Factor C/C_c	T_{max} (approx.)
Steel Spring	0.005	100
Elastomers:		
Natural Rubber	0.05	10
Neoprene	0.05	10
Butyl	0.12	4.0
Hi Damp Silicone	0.15	3.5
Polybutadiene	0.11	4.5
SBR	0.08	6.0
Friction Damped Springs		
Metal Mesh	0.12	4.0
Air Damping	0.17	3.0
Felt and Cork	0.06	8.0

Table 1. Damping factors for materials commonly used for isolators

The correlation between a high damped and a lightly damped system is shown in **Figure 8**. This figure shows that as damping is increased, isolation efficiency is reduced in the isolation region. While high values of damping cause significant reduction of transmissibility at resonance, its effect in the isolation region is only a small increase in transmissibility.

The curves which relate f_n , f_d , transmissibility and damping are shown in **Figure 8**.

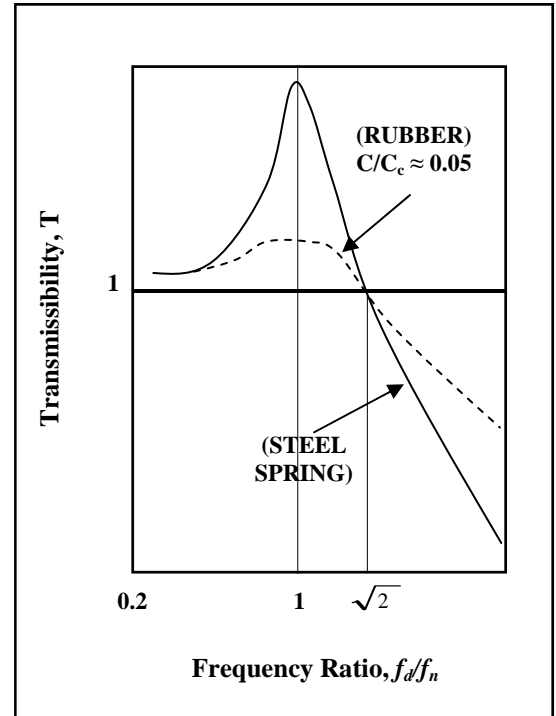

Figure 7. Typical transmissibility curves for highly and lightly damped systems.

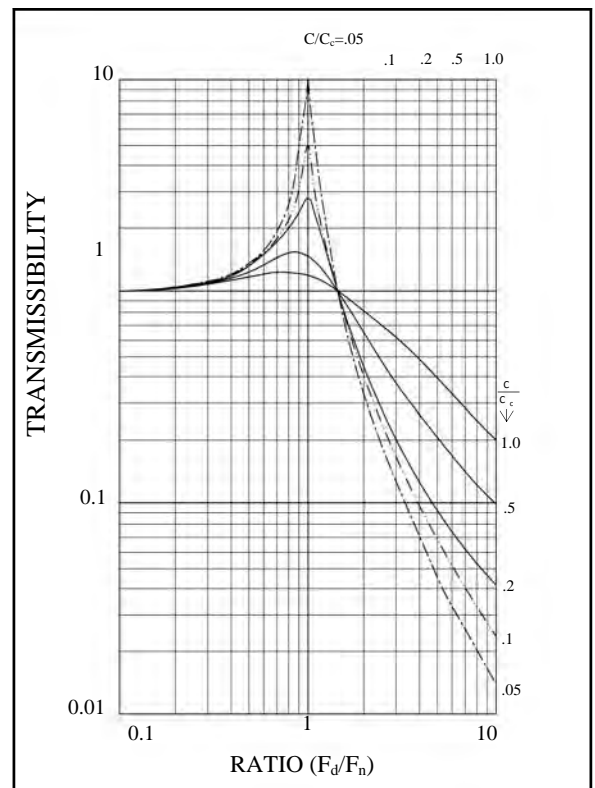

Figure 8. Family of transmissibility curves for a single degree of freedom system.

SHOCK

Shock is normally a transient event while vibration is a steady-state condition. A shock input is normally characterized by its peak amplitude in g's and a period that is normally expressed in milliseconds. The shock pulse will typically have a prescribed shape to it that is normally in the form of a half sine, sawtooth, etc., random shaped waveforms are shown in **Figure 9**.

There are a number of different types of shock pulses encountered in the real world. There are different shock tests that are associated with the environment that the equipment will encounter during its lifetime. Equipment installed in aircraft and helicopters is normally tested on a free-fall shock machine which will generate either a half-sine or sawtooth shaped pulse with a typical period of 11 milliseconds at 15 G input. Large shock pulses due to explosive shocks are 6-millisecond sawtooth at 100 g's. Navy vessels the normal test will be the hammer blow specified in MIL-S-901, which exhibits a velocity shock of approximately 100 in./sec. Transit cases or shipping containers are normally tested by dropping the container on a concrete floor. These drop tests can be done to simulate dropping the equipment on edge, flat side and corner drops. These types of tests simulate the shock pulse which will be encountered in the environment of the equipment.

The attenuation of shock inputs is very different from that of a vibration input. The shock isolator is characterized as an energy absorbing device, with a very steep wave front that is absorbed by the isolator. This energy is stored in the isolator and released at the natural frequency of the spring-mass damper system.

The most common equations for predicting shock isolation are in **Figure 9**, for determining the velocity, and **Equation 11**, for calculating transmitted accelerations.

The two methods for solving shock problems are valid as long as two criteria are met:

- 1) The shock pulse is fully defined, acceleration levels, the time history and the shape of the curve; and
- 2) The isolation system must respond to the shock event in the linear portion of the load verse deflection curve.

STRUCTURE-BORNE NOISE

By today's standard equipment and products are required to run faster and produce more at a very high rate. These higher rates cause higher noise and vibration to occur and must be dealt with to reduce overall fatigue of the components. High frequency vibrations can occur by this rapid movement of these mechanical or electromechanical components and cause structures that they are mounted to vibrate and produce noise. The best way to reduce the noise and vibration is to de-couple the vibration from the structure by using an elastomeric material. The elastomeric material will absorb the mechanical vibration forces to the structure and therefore reduce the overall noise. Constrained Layer Damping products can be applied to structures to reduce the overall noise signature very effectively. CLDM and other damping products have high levels of inherent damping and can be produced in various shapes

PROPERTIES	NATURAL RUBBER	NEOPRENE	HI-DAMP @SILICONE	POLYBUTADIENE
Adhesion to Metal	Excellent	Excellent	Good	Very Good
Tensile Strength	Excellent	Excellent	Good	Excellent
Tear Resistance	Good	Good	Fair	Good
Compression Set Resistance	Good	Fair	Fair	Good
Damping Factor C/C _c (approx.)	0.05	0.05	0.15	0.12
Operating Temperature (max)	200F	200F	300F	200F
Stiffness Increase (approx.)@ -65F	10X	10X	<2X	2X
Oil Resistance	Poor	Good	Fair	Fair
Ozone Resistance	Poor	Good	Excellent	Fair
Resistance to Sunlight Aging	Poor	Very Good	Excellent	Good
Resistance to Heat Aging	Fair	Good	Excellent	Good
Cost	Low	Low	High	Moderate

NONLINEAR ISOLATORS

Up to now we have assumed that all the isolation systems have a linear response, thus their load versus deflection curves are linear in shape. The theory is sound, most systems have steady state vibrations where amplitudes are small. Non-linear systems are used where the reverse is true: high transit vibration levels or high shock loads are present and space constraints are a premium. The level of isolation is proportional to the isolator's ability to accommodate the required deflection due to a heavy static load with an imposed high transit shock. Linear isolators require a high level of deflection to absorb the same transit condition than non-linear isolators and this space may not be available in the application. There are a couple of different techniques that can be applied to produce a non-linear isolation system.

- 1) The first is to increase the stiffness of the isolator in proportion as the deflection increases. The amount of deflection will be limited, and produce a higher G level imparted to the equipment.
- 2) The second method is to design the isolator to buckle as shown in **Figure 10**. The isolator is stiff as the linear portion of the curve and then has a relatively constant load over the higher deflection ranges. Since isolators are an energy absorbing device, the style isolator can store more energy for a given deflection based on the area under the load versus deflection curve.

Isolators and Materials

Isolators can be produced from a variety of materials that are both elastomeric and also combinations of spring with other mediums like air or friction. Each selection of materials should be chosen by the designer in accordance with the application and environmental conditions.

ELASTOMERIC ISOLATORS

Elastomers make excellent shock absorbing isolators because the damping level can be tailored to the application and they have high energy absorbing capacity. Elastomers can be molded using a typical rubber molding technique and constructed in numerous shapes to achieve both linear and non-linear isolators to achieve the appropriate shock isolation.

Drift or Creep is a negative occurrence with all elastomeric isolators and must be taken into account when designing isolators. The maximum static strain varies widely, but it may be taken as a conservative limitation that elastomers should not be continuously strained more than 10 to 15% in compression, nor more than 25 to 50% in shear. These rules of thumb are often used to determine the maximum load capacity of a given isolator.

In spite of the limitations of elastomeric materials used in isolators, the overall advantages far outweigh the disadvantages and make elastomers the most highly desirable type of resilient media for isolators.

SPRINGS

Metal springs can be used as vibration isolators. In some cases, these types of isolators work well. Springs lack damping and experience extremely violent motions that occur at resonance. (see "Damping" section and **Figure 8**).

SPRING-FRICTION DAMPER

To add damping in coil springs, friction dampers can be designed in parallel with the load-carrying spring. These types of isolators are widely used in practice. An example of this is illustrated in **Figure 11**.

The friction damped spring setup is composed of a set of split circular shoes that have a spring that separates the shoes at a fixed normal force that is applied against the wall of a round aluminum housing. There are two sets of springs that are used to support the static load. The normal force is provided by the weight of the equipment, and damping results from the sliding during horizontal excitations. Transmissibility values of about 2 to 2.5:1 are exhibited by using this type of spring/damper combination.

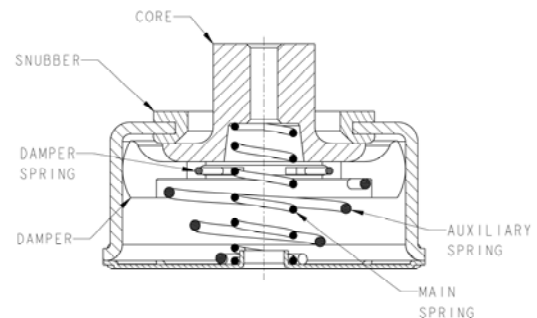

Figure 11. Isolator using friction damped spring.

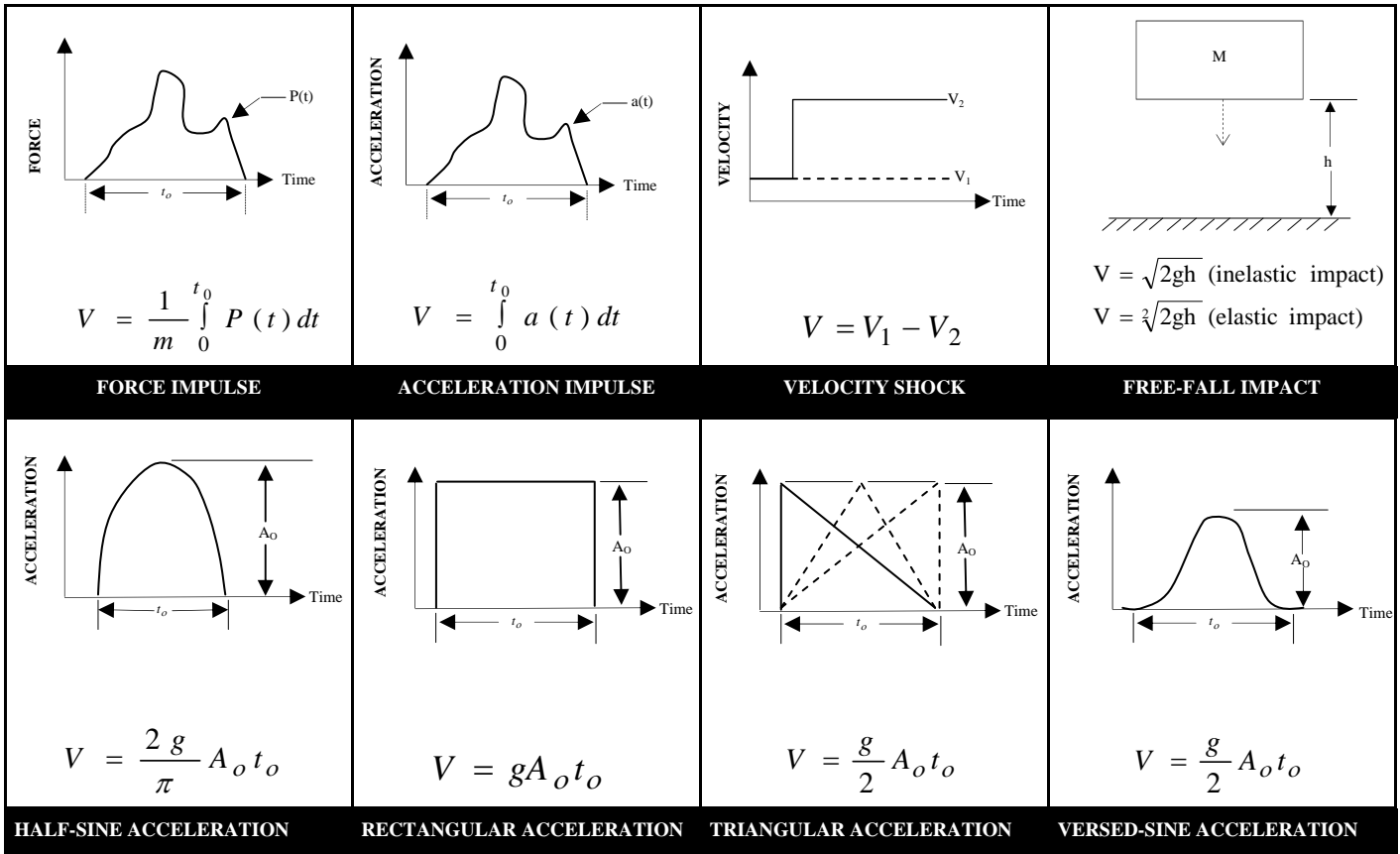

Figure 9. Shock excitation and the velocity change, V , associated with each shock pulse

SPRINGS WITH AIR DAMPING

An additional method of adding damping to a spring is by use of an air chamber or balloon with an orifice that meters the air flow. An example of this type of isolator is illustrated in **Figure 12**. A spring is located within the interior of an elastomeric balloon. The air chamber formed at the top of the balloon with a cap which contains an orifice or the force flow metering.

Under excitations the air volume in the balloon passes through a predetermined sized orifice by which damping is closely controlled. Transmissibility's generally under 3.5-4:1 result with this type of design.

Air-damped springs have some significant advantages over similar friction damped designs with respect to isolating low-level inputs.

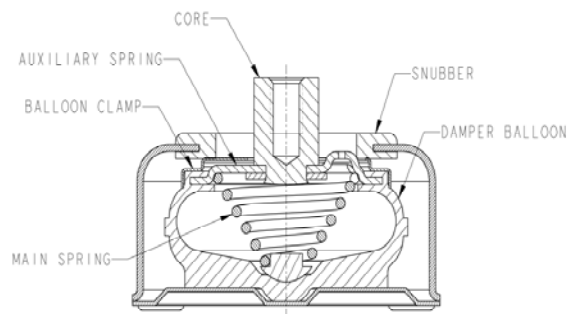

Figure 12. Isolator using air damped spring.

With friction damping, the friction force is constant. The damping ratio is effectively increased when the input levels are decreased. Referring to **Figure 8**, increasing the damping ratio decreases the level of isolation.

Friction Damped isolators are suited well for higher vibration levels where air damped systems are well suited for low level vibrations.

WIRE MESH DAMPING

Metal mesh isolators are used when there are high temperature extremes or other environmental factors, damping can be added to a load carrying spring by use of metal mesh inserts. When dynamic loads are applied, the wire mesh strands rub on each other and create friction and thus heat energy is dissipated creating damping. Transmissibility's under 6:1 are generally exhibited by the wire mesh damper.

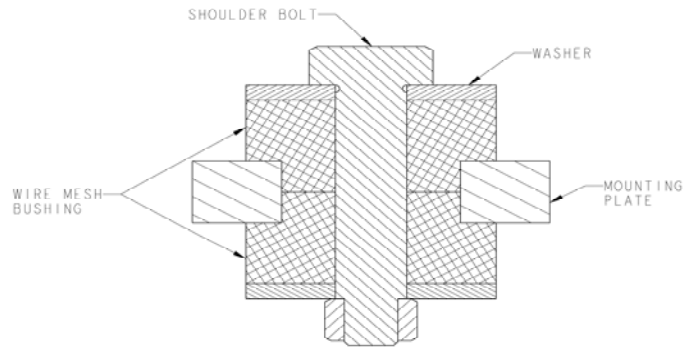

Figure 13. Isolator with wire mesh load carrying pad.

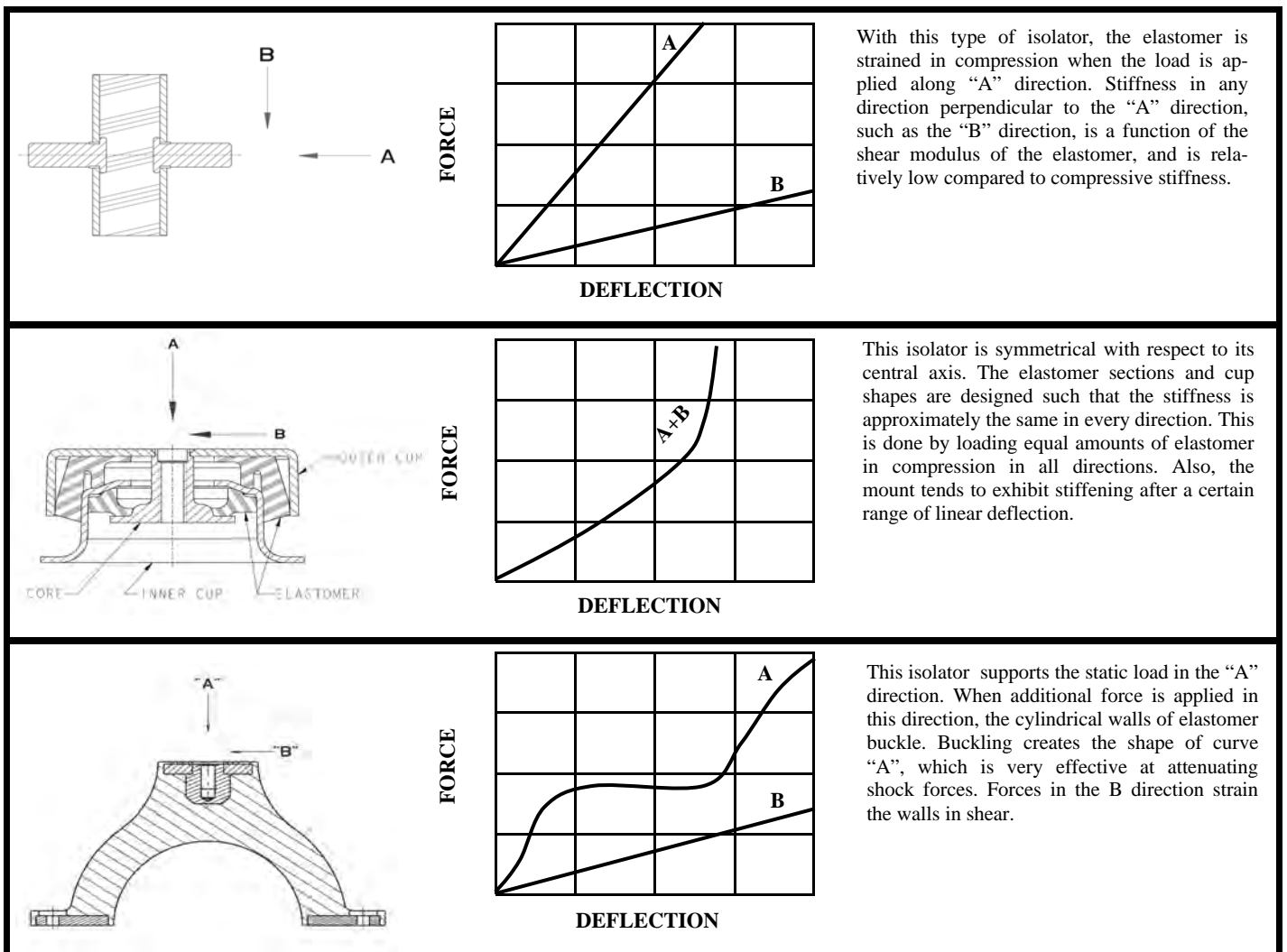

Figure 10. Force vs. Deflection curves for some typical elastomeric isolators.

PRODUCT MATRIX

The following two pages contain a product matrix of vibration and shock isolators that are used in various applications. We have shown some typical applications where these vibration and shock isolators are used. These are typical applications and the actual measured inputs may be different, the data should be reviewed to insure the proper isolator is selected for the specific application.

Product	P/N	Axial Load Range (lbs.)	Natural Frequency (Hz)	Axial/Radial Stiffness Ratio	Standard Structural Material
Cupmounts	2100, 1870, 1871, 1872 & 1873	5-1800	20-45	1:1	Zinc Plated Steel
Armor Flex™ Mount Series	2131, 2132, 2133	990-1750	8-10	1:1	Zinc Plated Steel
Friction Style Mounts	1772 & 1773, 1900, 1901 & 1902	.4-40	7-10	4:1	Aluminum
Can Style Mounts	1766 & 1767 & 1769	1-80	15-50	1:1	Zinc Plated Steel, Stainless
SEM Series	SEM100 & SEM500	2.5-10	12-25	2:1	Aluminum
High Deflection Mounts	1829	5-15	12-20	1:1	Aluminum
High Deflection Mounts	1824	12-30	25-40	2.5:1	Aluminum
High Deflection Mounts	1825	5-20	10-15	1:1.5	Aluminum
High Deflection Mounts	1975	45-150	12-25	2:1	Zinc Plated Steel
High Deflection Mounts	1774 & 1775 Series	60-260	8-10	4:1	Zinc Plated Steel
Low Profile Mounts	1830 & 1831 Series	4.50-10	25-40	1:1	Aluminum, Zinc Plated Steel
Fail-Safe Compression Mounts	1751-1757 Series	100-1780	10-20	1:1	Zinc Plated Steel
Fail-Safe Compression Mounts	1804 & 1805 Series	50-420	10-20	6:1	Zinc Plated Steel
Ring & Bushing Mounts	1761-1765 Series	40-4560	10-20	1:1	Zinc Plated Steel
Bushing Series	2061-2065 Series	40-4560	10-20	1:1	Zinc Plated Steel
Center Bond Series	EP2001-2012	75-2400	10-20	Varies	Zinc Plated Steel
Platform Mounts	EP3001-3156	3-90	8-10	1:1	Zinc Plated Steel
Cylindrical Mounts	EP1000-1830	3-560	8-20	Varies	Zinc Plated Steel
All Elastomer Ring & Bushing Mount Series	1815-1827 Series	1-350	20-45	Varies	N/A
All Elastomer Ball Mount Series	1893 Series	.9-3.5	10-20	1:1	N/A
Dome Mounts	1961 Series	375-1425	10-15	1:1	Zinc Plated Steel
Fluid Mount	1962, 1969, 2006	3-17	8-10	Axial Only	Stainless Steel
English Air Isolators	3001-3008	100-19200	3-15	Axial Only	Steel
Metric Air Isolators	3009-3015	100-7500	3-15	Axial Only	Steel
CushyFlex Mounts	2182, 2183, 2184	110-2200	8-10	1:2.5: .75	Zinc Plated Steel
Sandwich Mounts	2205, 2206, 2207	210-4190	10-20		Zinc Plated Steel

Standard Resilient Material	Primary Application	Major Attributes	
Neoprene, Silicone, Natural Rubber	Aircraft, Missiles, Military Vehicles	Low-Profile, Rugged, High-Shock	
Neoprene	Marine, Construction	Low Profile, Rugged	
Friction Damped Springs	Aircraft, Helicopters, Naval Marine, Electronics	Friction-Damped	
Hi Damped Silicone	Aircraft, Missiles, Military Vehicles, Marine	Low-Profile, Rugged, Fail-Safe	
Neoprene	Business, Agricultural, Construction, Marine	Low-Profile, Buckling Design	
Hi Damped Silicone, Neoprene	Military Electronics, Military Aircraft, Helicopters, Military Vehicles	Buckling	
Hi Damped Silicone, Neoprene	Military Electronics, Military Aircraft, Helicopters, Military Vehicles	Buckling	
Hi Damped Silicone	Helicopters, HUMVEE	Buckling	
Neoprene, Polybutadiene	Industrial Machinery, Naval marine, Labs	Buckling	
Neoprene	Industrial Machinery, Labs	Buckling	
Hi-Damped Silicone	Military Electronics, Military Aircraft, Helicopters, Military Vehicles	Low-Profile, All Attitude	
Neoprene	Business, Agricultural, Construction, Marine	Rugged, All Attitude	
Neoprene	Business, Agricultural, Construction, Marine	Rugged, All Attitude, Low Profile	
Neoprene	Industrial Machinery, Agricultural, Construction, Marine	Rugged, All Attitude, Fail-Safe	
Neoprene	Industrial Machinery, Agricultural, Construction, Marine	Rugged, All Attitude, Fail-Safe, Easy Installation	
Neoprene	Industrial Machinery, Agricultural, Construction, Marine	Rugged, All Attitude, Fail-Safe, Easy Installation	
Neoprene	Industrial Machinery, Agricultural, Construction, Marine	All Attitude, Easy Installation	
Natural Rubber	Business, Agricultural, Construction, Marine	Very Low-Cost	
Natural Rubber	Industrial Machinery, Agricultural, Construction, Marine	All Elastomer	
Neoprene	Business, Agricultural, Construction, Marine	Light Loads, Low-Cost	
Neoprene	Industrial Machinery, Agricultural, Construction, Marine	Rugged, All Attitude, Fail-Safe, Easy Installation	
Hi-Damped Silicone	Military Electronics, Military Aircraft, Helicopters, Military Vehicles	Low-Profile, Very Hi-Damped	
Neoprene	Industrial Machinery, Agricultural, Construction, Marine	Low frequency, very high load range English Threads	
Neoprene	Industrial Machinery, Agricultural, Construction, Marine	Low frequency, very high load range Metric Threads	
Neoprene	Marine, Construction	Rugged, All Steel, Fail-Safe	
Neoprene	Industrial, Marine	Rugged, Compact	

ALL ELASTOMER ISOLATORS



All Elastomer Ring & Bushing Mount Series

Low cost, easily installed elastomeric isolators that protect against shock and vibration

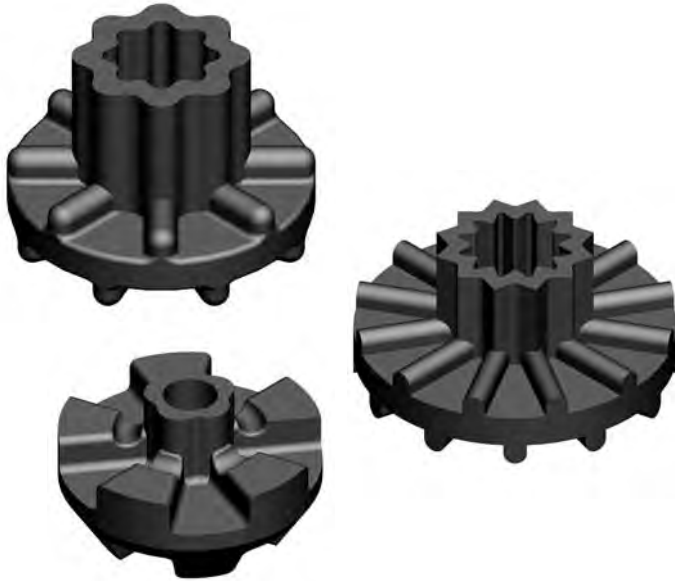

Applications

- Pumps
- Electric motors
- Fans & blowers
- HVAC
- Communications equipment
- Business machines
- Electronics

Load Range

- 1815/1816 = 4 load ratings to 12 lbs. max.
- 1818/1819 = 4 load ratings to 35 lbs. max.
- 1821/1822 = 4 load ratings to 75 lbs. max.
- 1826/1827 = 4 load ratings to 350 lbs. max.

Attributes

- Available in four sizes
- Low-cost but effective isolation
- Ribbed design aids in isolation
- Can be installed in parallel or series for greater load capacity or deflection

Specifications

- Natural Frequency—See tables
- Transmissibility at resonance—10:1
- Resilient Element—Natural Rubber
- Standard materials—None
- Weight—1826 = 3.37 oz. (all other parts weigh less than 1.0 oz.)

Elastomeric Data

- Natural rubber elastomer is compatible with most industrial and commercial environments and has an operating temperature range of -25°F to $+160^{\circ}\text{F}$ (-37°C to $+70^{\circ}\text{C}$). Special materials are available upon special order.

All Elastomer Ring & Bushing Mount Series: 1815/1816

Dimension and Performance Characteristics

RECOMMENDED LOAD LIMITS FOR RING & BUSHING ASSEMBLY					
Part #	Size	Minimum Load (lbs.)	Max. Load (lbs.)	Standard Material / Durometer	FN at max load
1815/1816 -1	1	1	4	Neoprene 30	16
1815/1816 -2	1	2	6	Neoprene 40	16.5
1815/1816 -3	1	3	8	Neoprene 50	21
1815/1816 -4	1	5	12	Neoprene 60	19

Dimensional
tolerance $\pm .03''$

1815 (Bushing)

1816 (Ring)

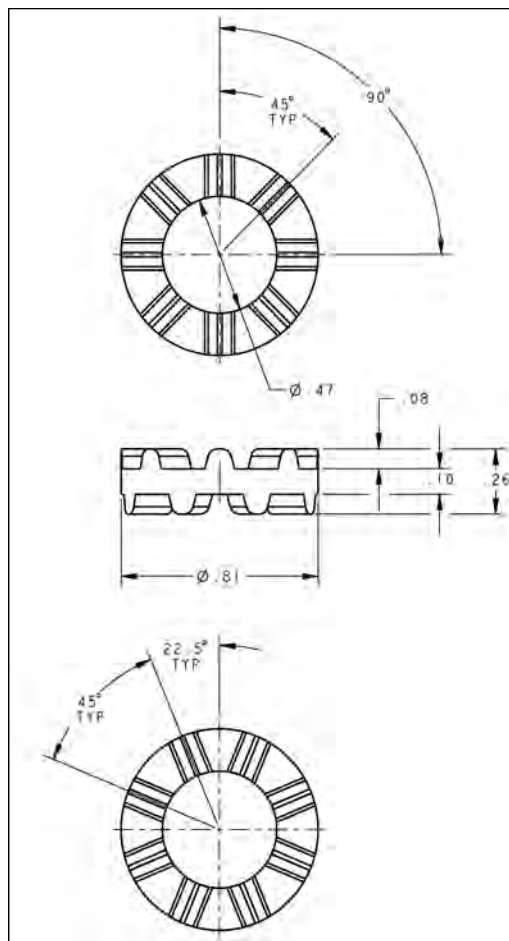
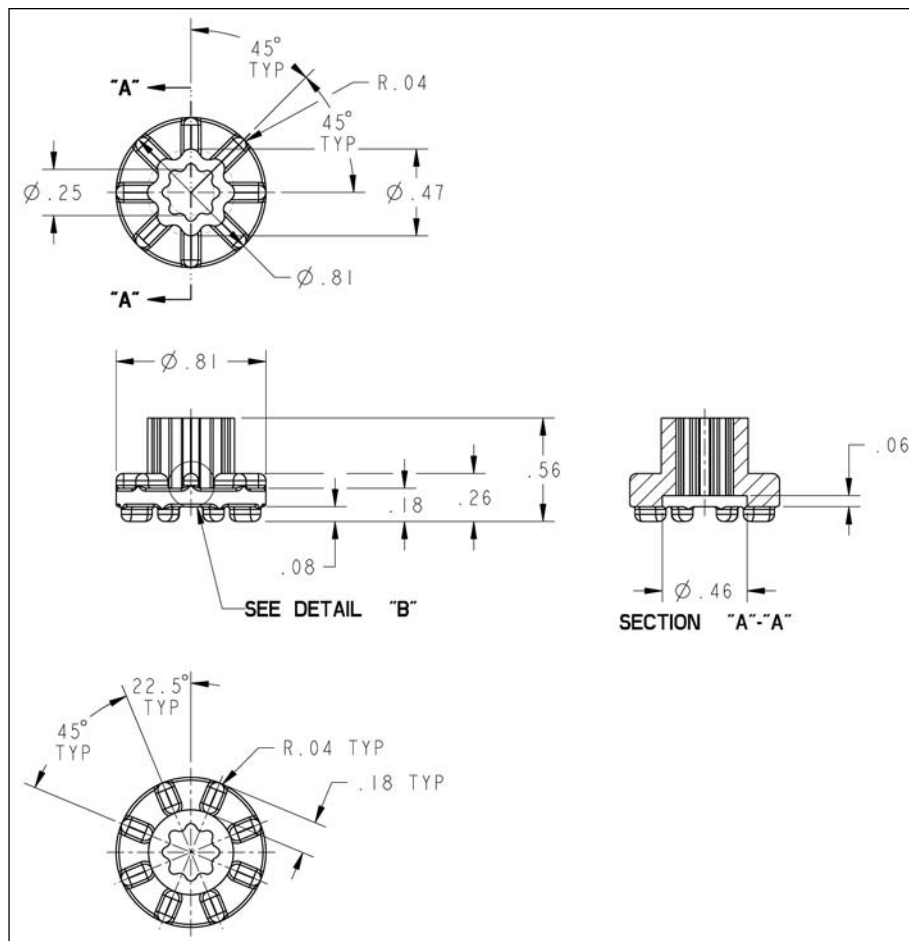

All Elastomer Ring & Bushing Mount Series: 1818/1819

Dimension and Performance Characteristics

RECOMMENDED LOAD LIMITS FOR RING & BUSHING ASSEMBLY					
Part #	Size	Minimum Load (lbs.)	Max. Load (lbs.)	Standard Material / Durometer	FN at max load
1818/1819 -1	3	6	20	Neoprene 30	14
1818/1819 -2	3	7	23	Neoprene 40	15
1818/1819 -3	3	10	25	Neoprene 50	19
1818/1819 -4	3	15	35	Neoprene 60	19

**Dimensional
tolerance $\pm .03$ "**

1818 (Bushing)

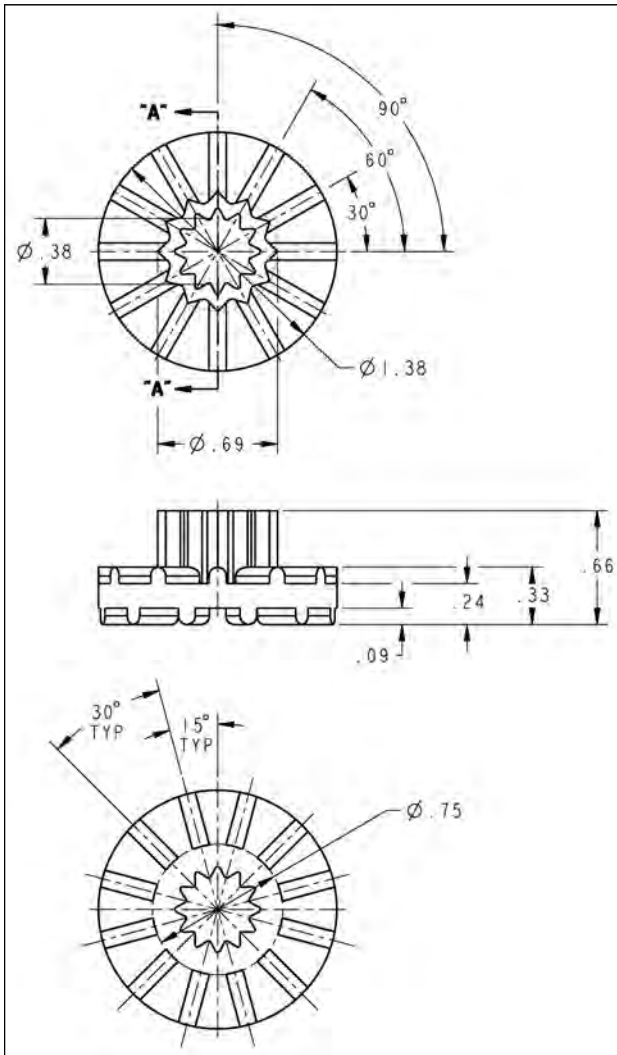

1819 (Ring)

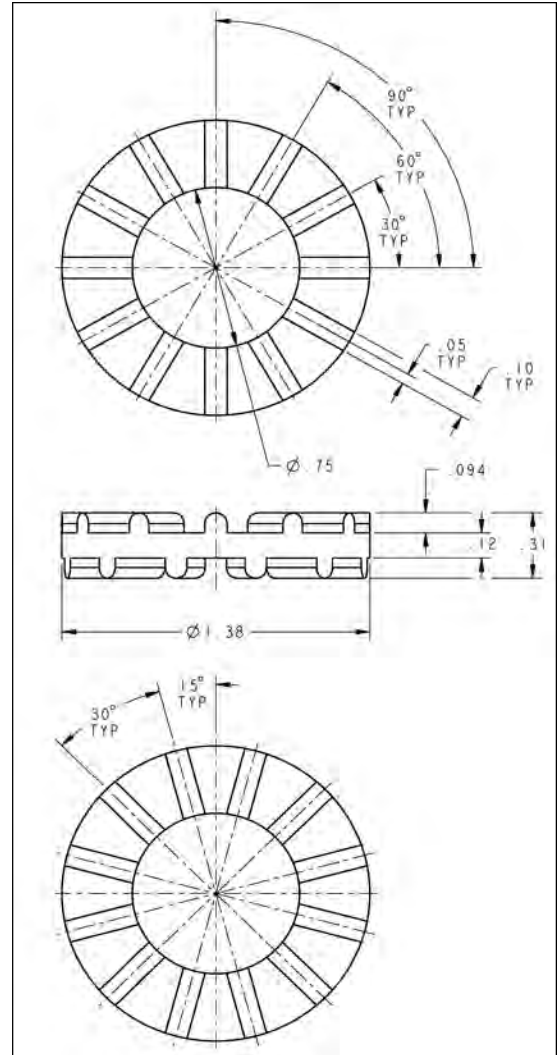

All Elastomer Ring & Bushing Mount Series: 1821/1822

Dimension and Performance Characteristics

RECOMMENDED LOAD LIMITS FOR RING & BUSHING ASSEMBLY					
Part #	Size	Minimum Load (lbs.)	Max. Load (lbs.)	Standard Material / Durometer	FN at max load
1821/1822 -1	4	10	35	Neoprene 30	10
1821/1822 -2	4	20	50	Neoprene 40	11
1821/1822 -3	4	30	60	Neoprene 50	12
1821/1822 -4	4	40	75	Neoprene 60	14

Dimensional
tolerance $\pm .03''$

1821 (Bushing)

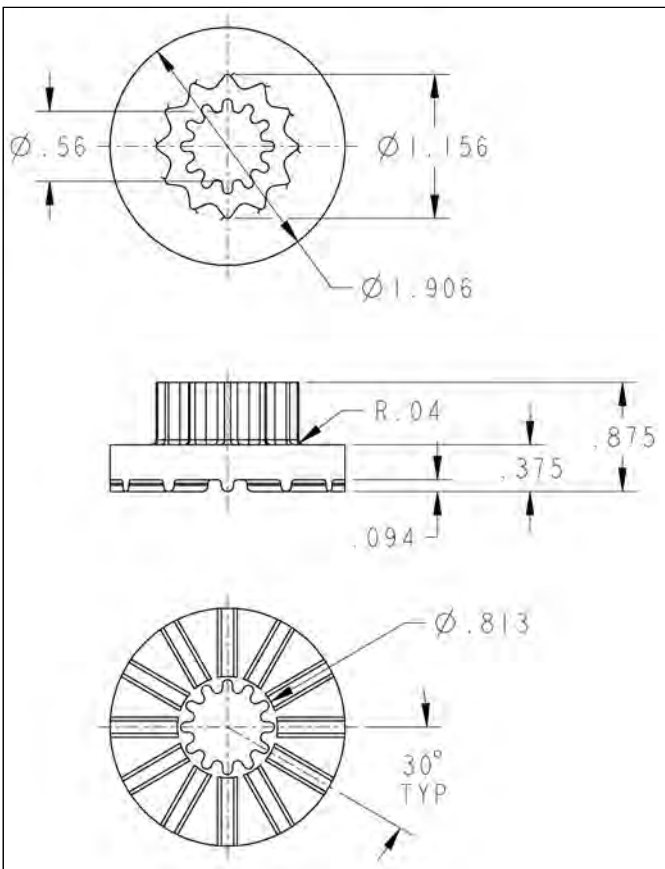

1822 (Ring)

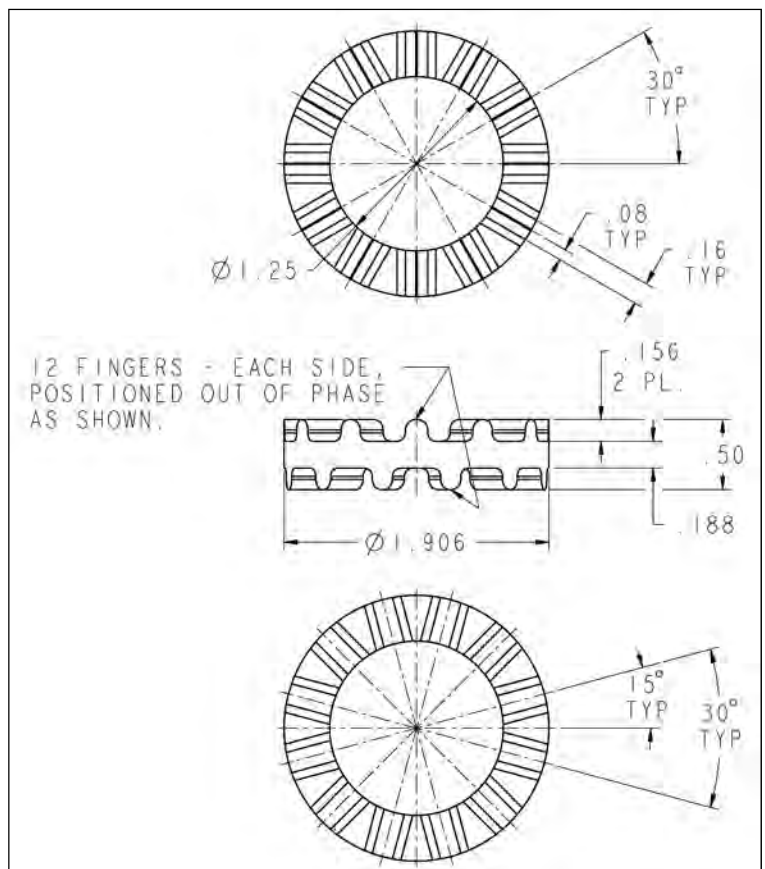

All Elastomer Ring & Bushing Mount Series: 1826/1827

Dimension and Performance Characteristics

RECOMMENDED LOAD LIMITS FOR RING & BUSHING ASSEMBLY					
Part #	Size	Minimum Load (lbs.)	Max. Load (lbs.)	Standard Material / Durometer	FN at max load
1826/1827 -1	6	60	120	Neoprene 30	7
1826/1827 -2	6	110	160	Neoprene 40	7
1826/1827 -3	6	135	250	Neoprene 50	7.5
1826/1827 -4	6	160	350	Neoprene 60	8

Dimensional
tolerance $\pm .03"$

1826 (Bushing)

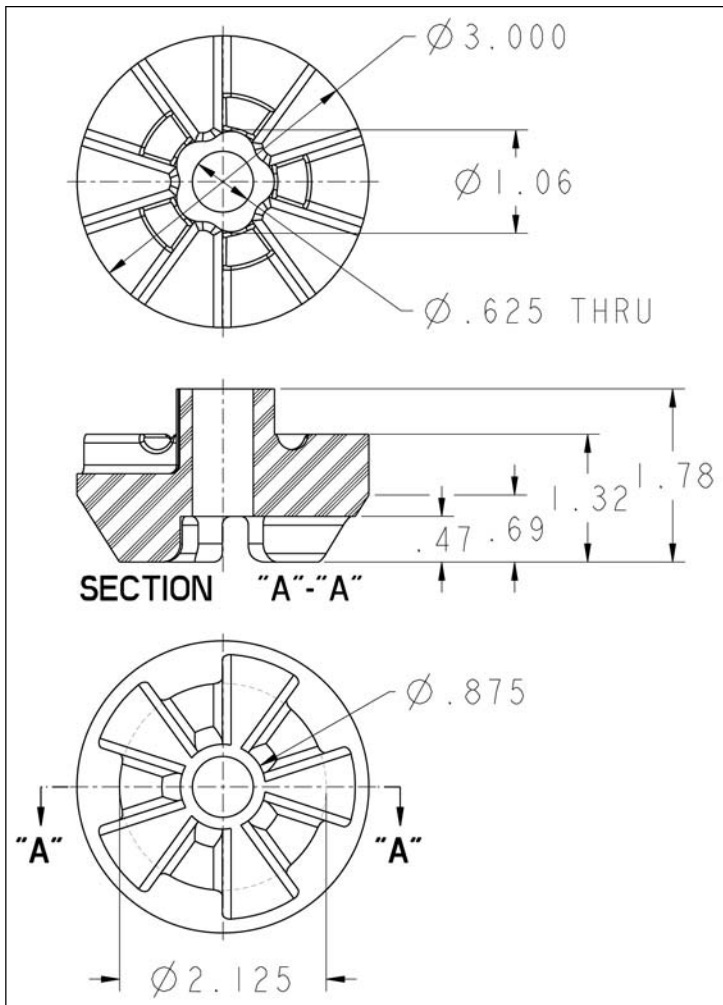

1827 (Ring)

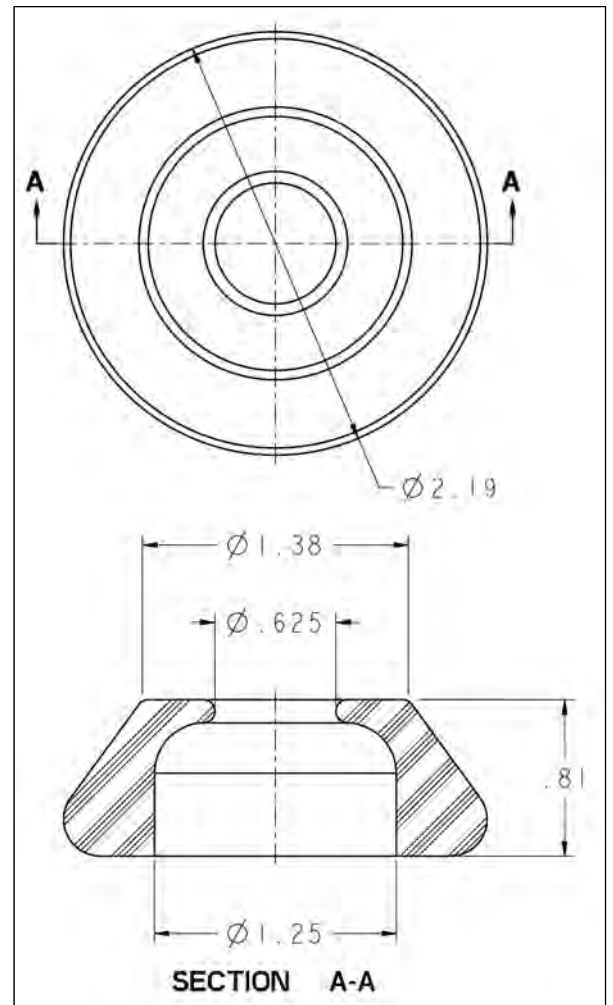

Ball Mount Series

Low cost, low profile, easily installed elastomer mounts for vibration and structure borne noise control



Attributes

- Simple buckling design
- Effective on very light loads
- Fail-safe when installed with industry standard bolts, nuts and washers
- Can be installed in multiple configurations

Applications

- Electronic cabinet panels
- Electromechanical equipment
- Small appliance
- Medical equipment
- Lightweight devices
- Business machines

Benefits

- One-piece design
- Effective isolation for low frequency inputs
- Survives light shock applications
- Effective for isolation for structure borne noise

Load Range

- 1893-1 = load ratings to .7 lbs. max.
- 1893-2 = load ratings to 1.2 lbs. max.
- 1893-3 = load ratings to 1.6 lbs. max.
- 1893-4 = load ratings to 2.6 lbs. max.
- 1893-5 = load ratings to 3.2 lbs. max.

Specifications

- Natural Frequency—10-20 Hertz
- Transmissibility at resonance—10 (Neoprene) /4.0 (Silicone)
- Resilient Element—Neoprene or Hi-damp Silicone
- Standard materials—None
- Weight—See load range table

Elastomeric Data

- Neoprene elastomer has an operating temperature range of -40°F to 200°F (-40°C to $+93^{\circ}\text{C}$) and is resistant to most solvents, oils and ozone.
- Silicone elastomer has an operating temperature range of -67°F to $+300^{\circ}\text{F}$ (-55°C to $+150^{\circ}\text{C}$)

Ball Mount Series: 1893

Dimensions and Load Ranges

Axial to Radial Stiffness 3:1

Part Number	Standard Material / Durometer	Color Code	Static Load Range/Mount (lbs.)
1893-1	35 Shore A Neoprene	Red	0.4-0.7
1893-2	45 Shore A Neoprene	Orange	0.6-1.2
1893-3	55 Shore A Neoprene	White	0.8-1.6
1893-4	65 Shore A Neoprene	Blue	1.3-2.6
1893-5	75 Shore A Neoprene	Green	1.6-3.2

Dimensional tolerance $\pm .015''$

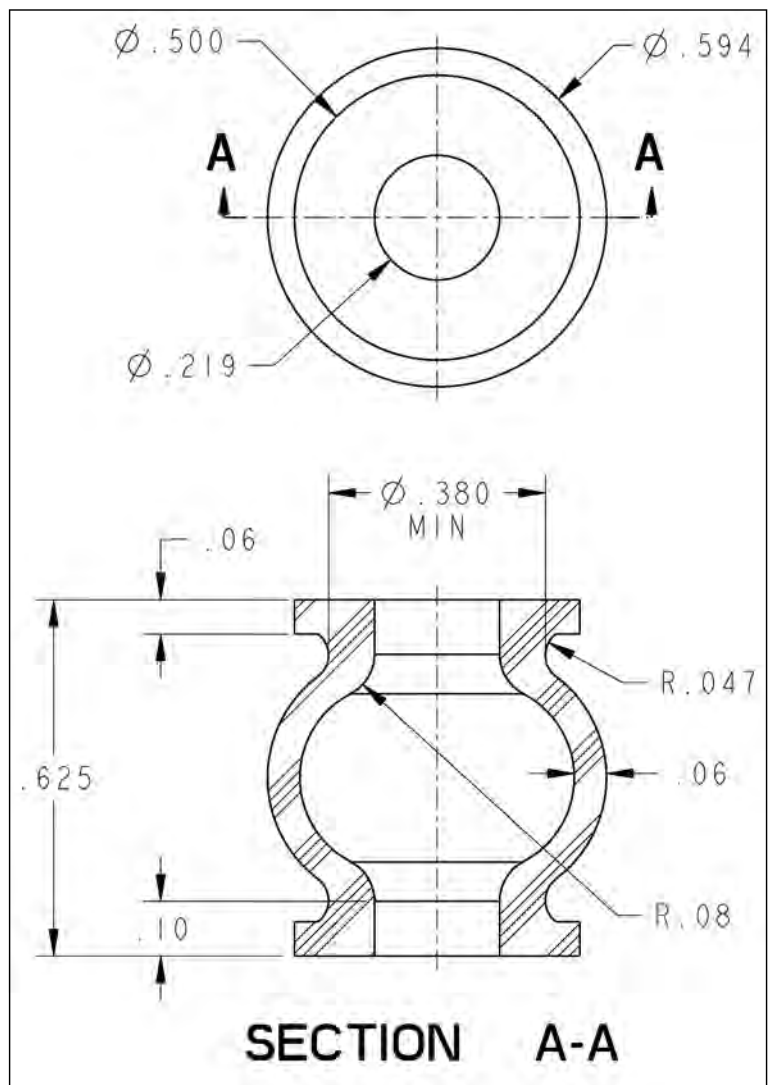

Ball Mount Series: 1893

Dimensions and Load Ranges

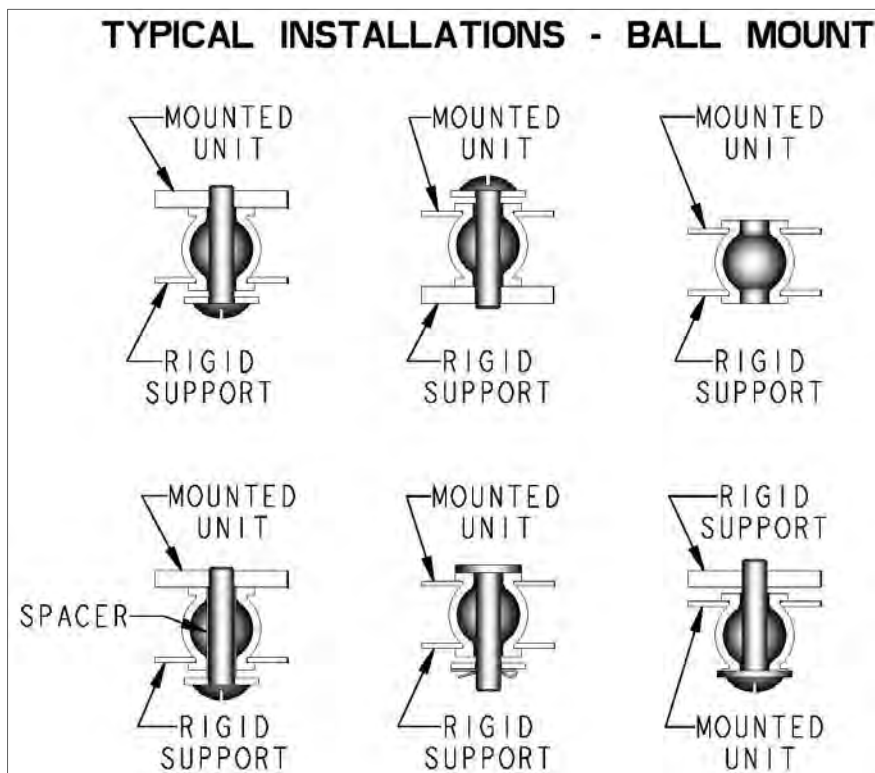
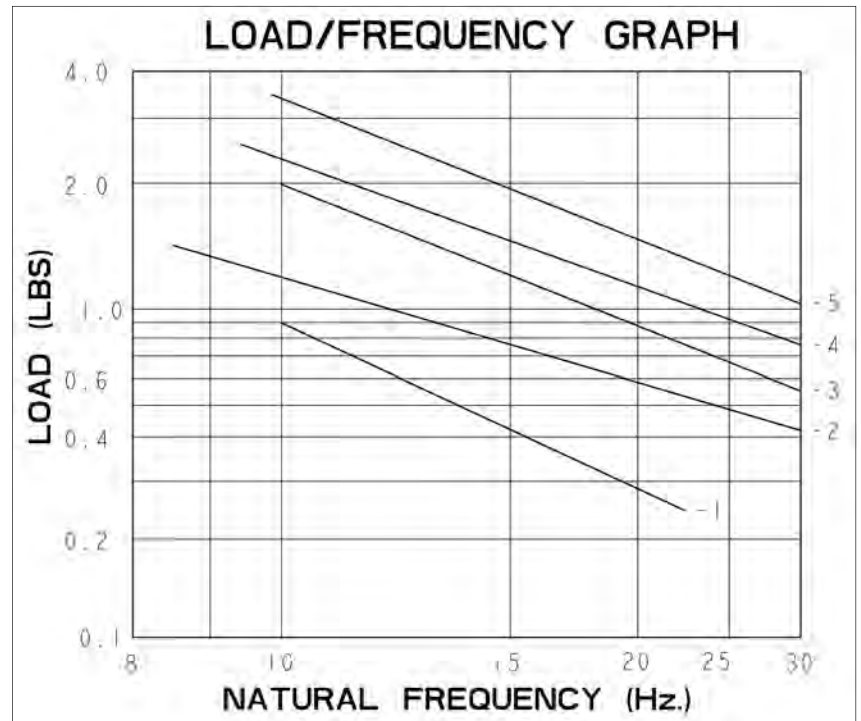

SECTION B INTENTIONALLY LEFT BLANK

CENTERBOND SERIES



Centerbond Series

Low cost, elastomeric mount to reduce vibration and shock

C



Applications

- Engine mounts
- Cab mounts
- Radiator mounts
- Pumps
- Air Compressors

Load Range

- EP2001 = load ratings to 160 lbs. max.
- EP2002 = load ratings to 520 lbs. max.
- EP2003 = load ratings to 720 lbs. max.
- EP2004 = load ratings to 720 lbs. max.
- EP2005 = load ratings to 1100 lbs. max.
- EP2006 = load ratings to 1500 lbs. max.
- EP2007 = load ratings to 2400 lbs. max.
- EP2012 = load ratings to 300 lbs. max.

Attributes

- Single bonded design
- Low profile design
- Low cost and easy to install
- Fail-safe when using a snubbing washer
- Axial and radial isolation

SNUBBING WASHERS

PART NUMBER	O.D"	I.D"	THICKNESS "	MATERIAL	FINISH	CENTERBOND PART NUMBER
SW-1120-0400-0125-SZ	1.12"	.400"	.125"	1010-1020 CRS	Clear Zinc	EP2001
SW-1500-0520-0125-SZ	1.50"	.520"	.125"	1010-1020 CRS	Clear Zinc	EP2002, EP2012-01 thru EP2012-04
SW-1700-0625-0125-SZ	1.70"	.625"	.125"	1010-1020 CRS	Clear Zinc	EP2003
SW-1700-0650-0125-SZ	1.70"	.650"	.125"	1010-1020 CRS	Clear Zinc	EP2004
SW-2500-0650-0190-SZ	2.50"	.650"	.190"	1010-1020 CRS	Clear Zinc	EP2005-EP2006
SW-2700-0800-0190-SZ	2.70"	.80"	.190"	1010-1020 CRS	Clear Zinc	EP2007
SW-1500-0375-0125-SZ	1.50"	.375"	.125"	1010-1020 CRS	Clear Zinc	EP2012-11 thru EP2012-14

Specifications

- Resilient Element—Natural Rubber or Neoprene
- Standard materials— Steel

Elastomeric Data

- Natural Rubber elastomer has an operating temperature range of -25°F to $+160^{\circ}\text{F}$ (-37°C to $+70^{\circ}\text{C}$).
- Neoprene elastomer is also available

Centerbond Series

Dimensional Drawing and Load Ranges

PART NUMBER	MAX LOAD	AXIAL SPRING RATE (lbs./in.)	A	B	C	D	E (MIN)	F (MIN)	G	H	I	J	R (MIN)
EP2001-01	30	1,000											
EP2001-02	50	2,000											
EP2001-03	80	4,200	0.31	0.22	0.69	0.40	1.25	1.10	0.81	0.75	1.09	0.80	0.06
EP2001-04	140	9,750											
EP2001-11	45	1,800											
EP2001-12	75	3,000											
EP2001-13	125	5,000	0.31	0.22	0.62	0.40	1.25	1.10	0.81	0.75	1.09	1.02	0.06
EP2001-14	160	6,400											
EP2002-01	130	2,000											
EP2002-02	190	3,875											
EP2002-03	300	7,500	0.41	0.38	1.00	0.47	2.00	1.50	1.24	1.12	1.75	1.25	0.06
EP2002-04	520	15,500											
EP2002-11	130	2,000											
EP2002-12	190	3,875											
EP2002-13	300	7,500	0.41	0.38	1.00	0.52	2.00	1.50	1.24	1.12	1.75	1.25	0.06
EP2002-14	520	15,500											
EP2003-01	230	3,400											
EP2003-02	360	6,000											
EP2003-03	520	10,600	0.50	0.53	1.00	0.53	2.25	1.70	1.35	1.25	2.00	1.25	0.06
EP2003-04	720	18,200											
EP2003-11	230	3,400											
EP2003-12	360	6,000											
EP2003-13	520	10,600	0.50	0.53	1.00	.625	2.25	1.70	1.35	1.25	2.00	1.25	0.06
EP2003-14	720	18,200											
EP2004-01	230	3,400											
EP2004-02	360	6,000											
EP2004-03	520	10,600	0.62	0.53	1.38	0.53	2.25	1.70	1.35	1.25	2.00	1.61	0.06
EP2004-04	720	18,200											
EP2004-11	230	3,400											
EP2004-12	360	6,000											
EP2004-13	520	10,600	0.62	0.53	1.38	0.64	2.25	1.70	1.35	1.25	2.00	1.61	0.06
EP2004-14	720	18,200											

Centerbond Series

Dimensional Drawing and Load Ranges

C

PART NUMBER	MAX LOAD	AXIAL SPRING RATE (lbs./in.)	A	B	C	D	E (MIN)	F (MIN)	G	H	I	J	R (MIN)
EP2005-01	400	4,450											
EP2005-02	540	7,500											
EP2005-03	750	12,900	0.75	0.62	1.75	0.64	2.85	2.20	1.61	1.50	2.50	2.00	0.06
EP2005-04	1100	22,000											
EP2006-01	600	5,200											
EP2006-02	800	9,400											
EP2006-03	1100	15,000	0.93	0.71	2.00	0.64	3.50	2.50	1.96	1.81	2.97	2.22	0.12
EP2006-04	1500	23,500											
EP2007-01	950	6,500											
EP2007-02	1300	10,700											
EP2007-03	1850	18,500	0.75	0.94	2.12	0.77	4.25	2.70	2.20	2.00	3.68	2.50	0.12
EP2007-04	2400	26,700											
EP2012-01	60	660											
EP2012-02	100	1,112											
EP2012-03	200	2,230	.38	.55	1.07	.41	1.50	1.50	.95	.875	1.25	1.44	.06
EP2012-04	300	3,300											
EP2012-11	60	660											
EP2012-12	100	1,112											
EP2012-13	200	2,230	.38	.55	1.07	.34	1.50	1.50	.95	.875	1.25	1.44	.06
EP2012-14	300	3,300											

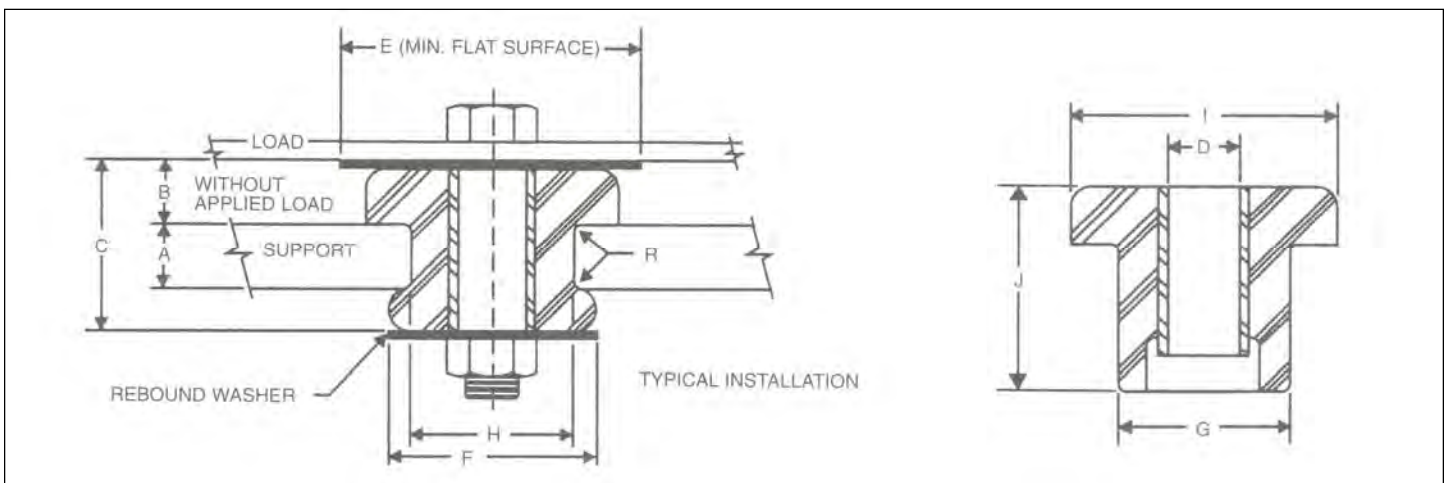

CUPMOUNT SERIES

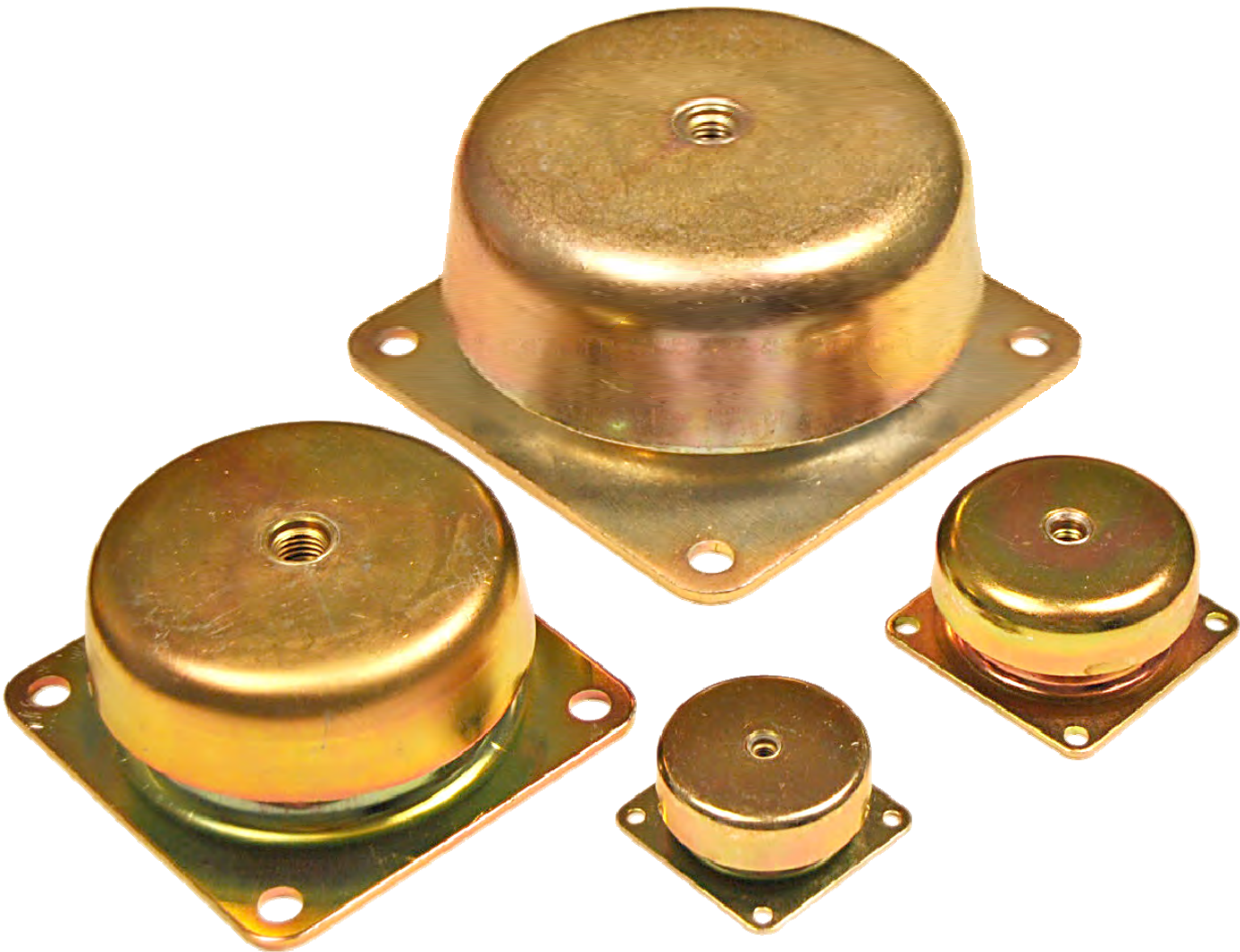

Size 0 Cupmount Series

A compact, universal mount used in the protection of equipment that is exposed to high shock and vibration environments

D



Attributes

- Fail-safe
- All-attitude design
- Compact, low profile design
- Easy to install
- High damped Silicone, Neoprene or Natural Rubber
- Zinc plated steel construction
- Can be used in tandem for higher deflection capability

Applications

- Shipboard equipment
- Mobile platforms
- Avionics
- Rack mounted systems
- Military radios
- Weapons system

Load Range

- 2100-1 = load ratings to 5 lbs./mount max.
- 2100-2 = load ratings to 10 lbs./mount max.
- 2100-3 = load ratings to 15 lbs./mount max.
- 2100-4 = load ratings to 20 lbs./mount max.

Shock & Vibe

- Attenuates a 10g, 11 millisecond half-sine shock to 2 g's
- Survives a 40g, 11 millisecond half-sine
- Passes MIL-STD-167 vibration

Specifications

- Natural Frequency — 20-45 Hertz
- Transmissibility at resonance — 4 max. (Hi-damp Silicone), 10 max. (Neoprene), 10 max. (Natural Rubber)
- Resilient Element — Hi-damp Silicone, Natural Rubber, Neoprene
- Standard materials — Zinc plated steel & black powder coated steel
- Weight — Size 0 = 2.58 oz.

Elastomeric Data

- High-Damp Silicone has an operating temperature of -67°F to +300°F (-55°C to +150°C) and is resistant to ozone, fungus and most solvents.
- Other elastomeric formulations are available in BUNA-N, Butyl, Polybutadiene and Neoprene.
- Neoprene has an operating range of -40°F to 200°F (-40°C to +93°C) and is used where oil immersion is present.
- Natural Rubber has an operating range of -25°F to +160°F (-37°C to +70°C) and is used in high dynamic amplitude environments.

Size 0 Cupmount: 2100

Dimension and Performance Characteristics

Part #	Size	Maximum Load (lbs.)	Load Range Shock lbs.	Free Height	Resilient Material	Structural Material	Core Style	Center Hole	Flange Holes	Transmissibility at Resonance Max.
2100-1SA	0	5	2-4	.83	Hi-Damp Silicone	Zinc Plated Steel	Threaded	8-32 UNC-2B	Ø.141	4:1
2100-2SA	0	10	4-7	.83	Hi-Damp Silicone	Zinc Plated Steel	Threaded	8-32 UNC-2B	Ø.141	4:1
2100-3SA	0	15	7-10	.83	Hi-Damp Silicone	Zinc Plated Steel	Threaded	8-32 UNC-2B	Ø.141	4:1
2100-4SA	0	20	10-14	.83	Hi-Damp Silicone	Zinc Plated Steel	Threaded	8-32 UNC-2B	Ø.141	4:1
2100-1SB	0	5	1-7	.83	Hi-Damp Silicone	Zinc Plated Steel	Thru Hole	Ø.172	Ø.141	4:1
2100-2SB	0	10	3-9	.83	Hi-Damp Silicone	Zinc Plated Steel	Thru Hole	Ø.172	Ø.141	4:1
2100-3SB	0	15	5-11	.83	Hi-Damp Silicone	Zinc Plated Steel	Thru Hole	Ø.172	Ø.141	4:1
2100-4SB	0	20	8-14	.83	Hi-Damp Silicone	Zinc Plated Steel	Thru Hole	Ø.172	Ø.141	4:1

Part #	Size	Maximum Load (lbs.)	Load Range Shock lbs.	Free Height	Resilient Material	Structural Material	Core Style	Center Hole	Flange Holes	Transmissibility at Resonance Max.
2100-1NA	0	5	2-4	.83	Neoprene	Zinc Plated Steel	Threaded	8-32 UNC-2B	Ø.141	10:1
2100-2NA	0	10	4-7	.83	Neoprene	Zinc Plated Steel	Threaded	8-32 UNC-2B	Ø.141	10:1
2100-3NA	0	15	7-10	.83	Neoprene	Zinc Plated Steel	Threaded	8-32 UNC-2B	Ø.141	10:1
2100-4NA	0	20	10-14	.83	Neoprene	Zinc Plated Steel	Threaded	8-32 UNC-2B	Ø.141	10:1
2100-1NB	0	5	1-7	.83	Neoprene	Zinc Plated Steel	Thru Hole	Ø.172	Ø.141	10:1
2100-2NB	0	10	3-9	.83	Neoprene	Zinc Plated Steel	Thru Hole	Ø.172	Ø.141	10:1
2100-3NB	0	15	5-11	.83	Neoprene	Zinc Plated Steel	Thru Hole	Ø.172	Ø.141	10:1
2100-4NB	0	20	8-14	.83	Neoprene	Zinc Plated Steel	Thru Hole	Ø.172	Ø.141	10:1

Size 0 Cupmount: 2100

Dimension and Performance Characteristics



Part #	Size	Maximum Load (lbs.)	Load Range Shock lbs.	Free Height	Resilient Material	Structural Material	Core Style	Center Hole	Flange Holes	Transmissibility at Resonance Max.
2100-1NRA	0	5	2-4	.83	Natural Rubber	Zinc Plated Steel	Threaded	8-32 UNC-2B	Ø.141	10:1
2100-2NRA	0	10	4-7	.83	Natural Rubber	Zinc Plated Steel	Threaded	8-32 UNC-2B	Ø.141	10:1
2100-3NRA	0	15	7-10	.83	Natural Rubber	Zinc Plated Steel	Threaded	8-32 UNC-2B	Ø.141	10:1
2100-4NRA	0	20	10-14	.83	Natural Rubber	Zinc Plated Steel	Threaded	8-32 UNC-2B	Ø.141	10:1
2100-1NRB	0	5	1-7	.83	Natural Rubber	Zinc Plated Steel	Thru Hole	Ø.172	Ø.141	10:1
2100-2NRB	0	10	3-9	.83	Natural Rubber	Zinc Plated Steel	Thru Hole	Ø.172	Ø.141	10:1
2100-3NRB	0	15	5-11	.83	Natural Rubber	Zinc Plated Steel	Thru Hole	Ø.172	Ø.141	10:1
2100-4NRB	0	20	8-14	.83	Natural Rubber	Zinc Plated Steel	Thru Hole	Ø.172	Ø.141	10:1

Part #	Size	Maximum Load (lbs.)	Load Range Shock lbs.	Free Height	Resilient Material	Structural Material	Core Style	Center Hole	Flange Holes	Transmissibility at Resonance Max.
2100-1SAPC	0	5	2-4	.83	Hi-Damp Silicone	Black Powder Coated Steel	Threaded	8-32 UNC-2B	Ø.141	4:1
2100-2SAPC	0	10	4-7	.83	Hi-Damp Silicone	Black Powder Coated Steel	Threaded	8-32 UNC-2B	Ø.141	4:1
2100-3SAPC	0	15	7-10	.83	Hi-Damp Silicone	Black Powder Coated Steel	Threaded	8-32 UNC-2B	Ø.141	4:1
2100-4SAPC	0	20	10-14	.83	Hi-Damp Silicone	Black Powder Coated Steel	Threaded	8-32 UNC-2B	Ø.141	4:1
2100-1SBPC	0	5	1-7	.83	Hi-Damp Silicone	Black Powder Coated Steel	Thru Hole	Ø.172	Ø.141	4:1
2100-2SBPC	0	10	3-9	.83	Hi-Damp Silicone	Black Powder Coated Steel	Thru Hole	Ø.172	Ø.141	4:1
2100-3SBPC	0	15	5-11	.83	Hi-Damp Silicone	Black Powder Coated Steel	Thru Hole	Ø.172	Ø.141	4:1
2100-4SBPC	0	20	8-14	.83	Hi-Damp Silicone	Black Powder Coated Steel	Thru Hole	Ø.172	Ø.141	4:1

Size 0 Cupmount: 2100

Dimension and Performance Characteristics

Part #	Size	Maximum Load (lbs.)	Load Range Shock lbs.	Free Height	Resilient Material	Structural Material	Core Style	Center Hole	Flange Holes	Transmissibility at Resonance Max.
2100-1NAPC	0	5	2-4	.83	Neoprene	Black Powder Coated Steel	Threaded	8-32 UNC-2B	Ø.141	10:1
2100-2NAPC	0	10	4-7	.83	Neoprene	Black Powder Coated Steel	Threaded	8-32 UNC-2B	Ø.141	10:1
2100-3NAPC	0	15	7-10	.83	Neoprene	Black Powder Coated Steel	Threaded	8-32 UNC-2B	Ø.141	10:1
2100-4NAPC	0	20	10-14	.83	Neoprene	Black Powder Coated Steel	Threaded	8-32 UNC-2B	Ø.141	10:1
2100-1NBPC	0	5	1-7	.83	Neoprene	Black Powder Coated Steel	Thru Hole	Ø.172	Ø.141	10:1
2100-2NBPC	0	10	3-9	.83	Neoprene	Black Powder Coated Steel	Thru Hole	Ø.172	Ø.141	10:1
2100-3NBPC	0	15	5-11	.83	Neoprene	Black Powder Coated Steel	Thru Hole	Ø.172	Ø.141	10:1
2100-4NBPC	0	20	8-14	.83	Neoprene	Black Powder Coated Steel	Thru Hole	Ø.172	Ø.141	10:1

Part #	Size	Maximum Load (lbs.)	Load Range Shock lbs.	Free Height	Resilient Material	Structural Material	Core Style	Center Hole	Flange Holes	Transmissibility at Resonance Max.
2100-1NRAPC	0	5	2-4	.83	Natural Rubber	Black Powder Coated Steel	Threaded	8-32 UNC-2B	Ø.141	10:1
2100-2NRAPC	0	10	4-7	.83	Natural Rubber	Black Powder Coated Steel	Threaded	8-32 UNC-2B	Ø.141	10:1
2100-3NRAPC	0	15	7-10	.83	Natural Rubber	Black Powder Coated Steel	Threaded	8-32 UNC-2B	Ø.141	10:1
2100-4NRAPC	0	20	10-14	.83	Natural Rubber	Black Powder Coated Steel	Threaded	8-32 UNC-2B	Ø.141	10:1
2100-1NRBPC	0	5	1-7	.83	Natural Rubber	Black Powder Coated Steel	Thru Hole	Ø.172	Ø.141	10:1
2100-2NRBPC	0	10	3-9	.83	Natural Rubber	Black Powder Coated Steel	Thru Hole	Ø.172	Ø.141	10:1
2100-3NRBPC	0	15	5-11	.83	Natural Rubber	Black Powder Coated Steel	Thru Hole	Ø.172	Ø.141	10:1
2100-4NRBPC	0	20	8-14	.83	Natural Rubber	Black Powder Coated Steel	Thru Hole	Ø.172	Ø.141	10:1

Size 0 Cupmount: 2100

Dimension and Performance Characteristics

D

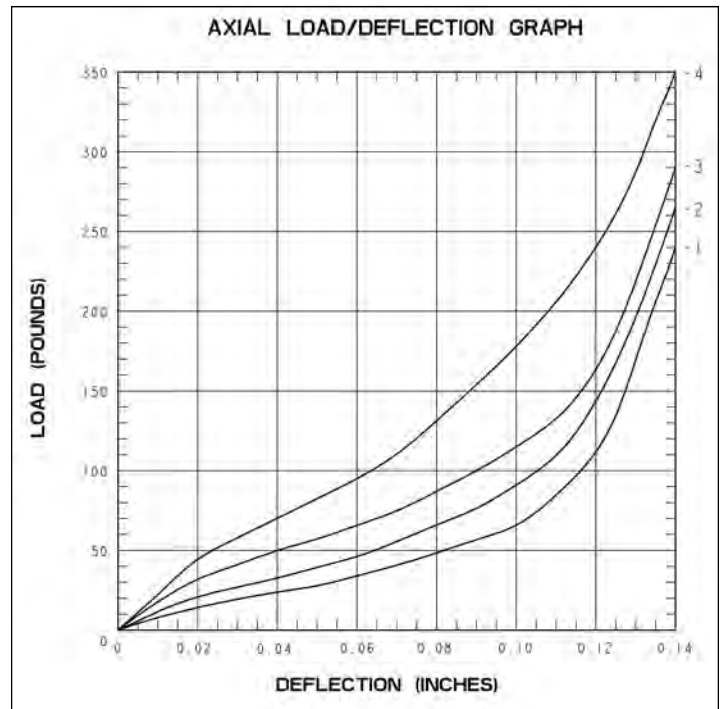
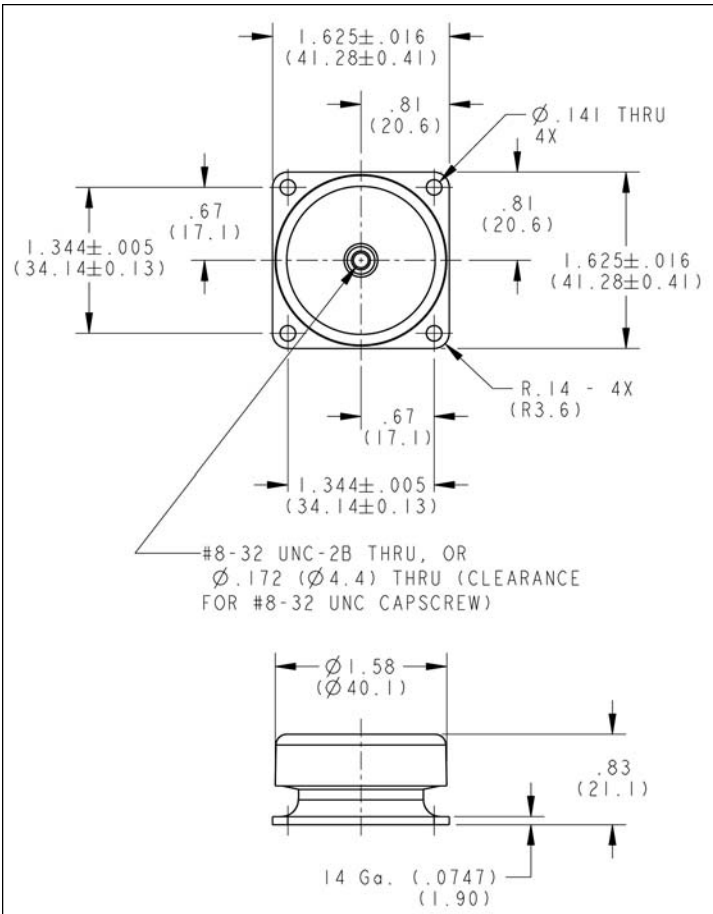

Size 1 Cupmount Series

A compact, universal mount used in the protection of equipment that is exposed to high shock and vibration environments

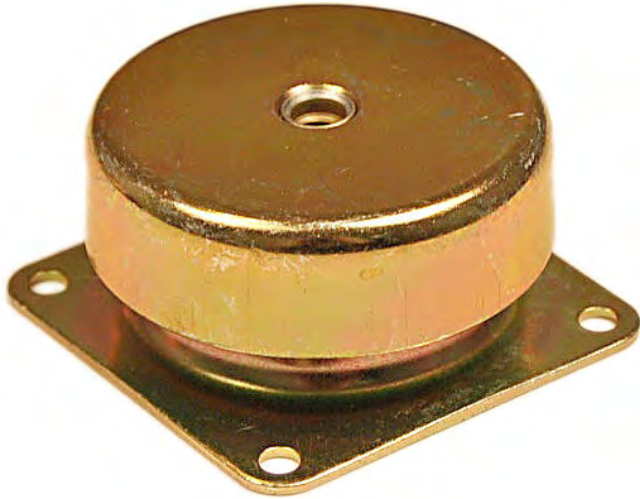

Attributes

- Fail-safe
- All-attitude design
- Compact, low profile design
- Easy to install
- High damped Silicone, Neoprene or Natural Rubber
- Zinc plated steel construction
- Can be used in tandem for higher deflection capability

Applications

- Shipboard equipment
- Mobile platforms
- Avionics
- Rack mounted systems
- Military radios
- Weapons system

Load Range

- 1870-1 = load ratings to 20 lbs./mount max.
- 1870-2 = load ratings to 30 lbs./mount max.
- 1870-3 = load ratings to 70 lbs./mount max.
- 1870-4 = load ratings to 100 lbs./mount max.

Shock & Vibe

- Attenuates a 10g, 11 millisecond half-sine shock to 2 g's
- Survives a 30g, 11 millisecond half-sine
- Passes MIL-STD-167 vibration

Specifications

- Natural Frequency—20-45 Hertz
- Transmissibility at resonance—4 max. (Hi-damp Silicone), 10 max. (Neoprene), 10 max. (Natural Rubber)
- Resilient Element—Hi-damp Silicone, Natural Rubber, Neoprene
- Standard materials—Zinc plated steel
- Weight—Size 1 = 6 oz.

Elastomeric Data

- High-Damp Silicone has an operating temperature of -67°F to $+300^{\circ}\text{F}$ (-55°C to $+150^{\circ}\text{C}$) and is resistant to ozone, fungus and most solvents.
- Other elastomeric formulations are available in BUNA-N, Butyl, Polybutadiene and Neoprene.
- Neoprene has an operating range of -40°F to 200°F (-40°C to $+93^{\circ}\text{C}$) and is used where oil immersion is present.
- Natural Rubber has an operating range of -25°F to $+160^{\circ}\text{F}$ (-37°C to $+70^{\circ}\text{C}$) and is used in high dynamic amplitude environments.

Size 1 Cupmount: 1870

Dimension and Performance Characteristics



Part #	Size	Maximum Load (lbs.)	Load Range Shock lbs.	Free Height	Resilient Material	Structural Material	Core Style	Center Hole	Flange Holes	Transmissibility at Resonance Max.
1870-1SA	1	20	8-14	1.17	Hi-Damp Silicone	Zinc Plated Steel	Threaded	1/4-20 UNC-2B	Ø.196	4:1
1870-2SA	1	30	14-24	1.17	Hi-Damp Silicone	Zinc Plated Steel	Threaded	1/4-20 UNC-2B	Ø.196	4:1
1870-3SA	1	70	24-38	1.17	Hi-Damp Silicone	Zinc Plated Steel	Threaded	1/4-20 UNC-2B	Ø.196	4:1
1870-4SA	1	100	38-60	1.17	Hi-Damp Silicone	Zinc Plated Steel	Threaded	1/4-20 UNC-2B	Ø.196	4:1
1870-1SB	1	20	8-14	1.17	Hi-Damp Silicone	Zinc Plated Steel	Thru Hole	Ø.266	Ø.196	4:1
1870-2SB	1	30	14-24	1.17	Hi-Damp Silicone	Zinc Plated Steel	Thru Hole	Ø.266	Ø.196	4:1
1870-3SB	1	70	24-38	1.17	Hi-Damp Silicone	Zinc Plated Steel	Thru Hole	Ø.266	Ø.196	4:1
1870-4SB	1	100	38-60	1.17	Hi-Damp Silicone	Zinc Plated Steel	Thru Hole	Ø.266	Ø.196	4:1

Part #	Size	Maximum Load (lbs.)	Load Range Shock lbs.	Free Height	Resilient Material	Structural Material	Core Style	Center Hole	Flange Holes	Transmissibility at Resonance Max.
1870-1NA	1	20	8-14	1.17	Neoprene	Zinc Plated Steel	Threaded	1/4-20 UNC-2B	Ø.196	10:1
1870-2NA	1	30	14-24	1.17	Neoprene	Zinc Plated Steel	Threaded	1/4-20 UNC-2B	Ø.196	10:1
1870-3NA	1	70	24-38	1.17	Neoprene	Zinc Plated Steel	Threaded	1/4-20 UNC-2B	Ø.196	10:1
1870-4NA	1	100	38-60	1.17	Neoprene	Zinc Plated Steel	Threaded	1/4-20 UNC-2B	Ø.196	10:1
1870-1NB	1	20	8-14	1.17	Neoprene	Zinc Plated Steel	Thru Hole	Ø.266	Ø.196	10:1
1870-2NB	1	30	14-24	1.17	Neoprene	Zinc Plated Steel	Thru Hole	Ø.266	Ø.196	10:1
1870-3NB	1	70	24-38	1.17	Neoprene	Zinc Plated Steel	Thru Hole	Ø.266	Ø.196	10:1
1870-4NB	1	100	38-60	1.17	Neoprene	Zinc Plated Steel	Thru Hole	Ø.266	Ø.196	10:1

Size 1 Cupmount: 1870

Dimension and Performance Characteristics

Part #	Size	Maximum Load (lbs.)	Load Range Shock lbs.	Free Height	Resilient Material	Structural Material	Core Style	Center Hole	Flange Holes	Transmissibility at Resonance Max.
1870-1NRA	1	20	8-14	1.17	Natural Rubber	Zinc Plated Steel	Threaded	1/4-20 UNC-2B	Ø.196	10:1
1870-2NRA	1	30	14-24	1.17	Natural Rubber	Zinc Plated Steel	Threaded	1/4-20 UNC-2B	Ø.196	10:1
1870-3NRA	1	70	24-38	1.17	Natural Rubber	Zinc Plated Steel	Threaded	1/4-20 UNC-2B	Ø.196	10:1
1870-4NRA	1	100	38-60	1.17	Natural Rubber	Zinc Plated Steel	Threaded	1/4-20 UNC-2B	Ø.196	10:1
1870-1NRB	1	20	8-14	1.17	Natural Rubber	Zinc Plated Steel	Thru Hole	Ø.266	Ø.196	10:1
1870-2NRB	1	30	14-24	1.17	Natural Rubber	Zinc Plated Steel	Thru Hole	Ø.266	Ø.196	10:1
1870-3NRB	1	70	24-38	1.17	Natural Rubber	Zinc Plated Steel	Thru Hole	Ø.266	Ø.196	10:1
1870-4NRB	1	100	38-60	1.17	Natural Rubber	Zinc Plated Steel	Thru Hole	Ø.266	Ø.196	10:1

Size 1 Cupmount: 1870

Dimension and Performance Characteristics

D

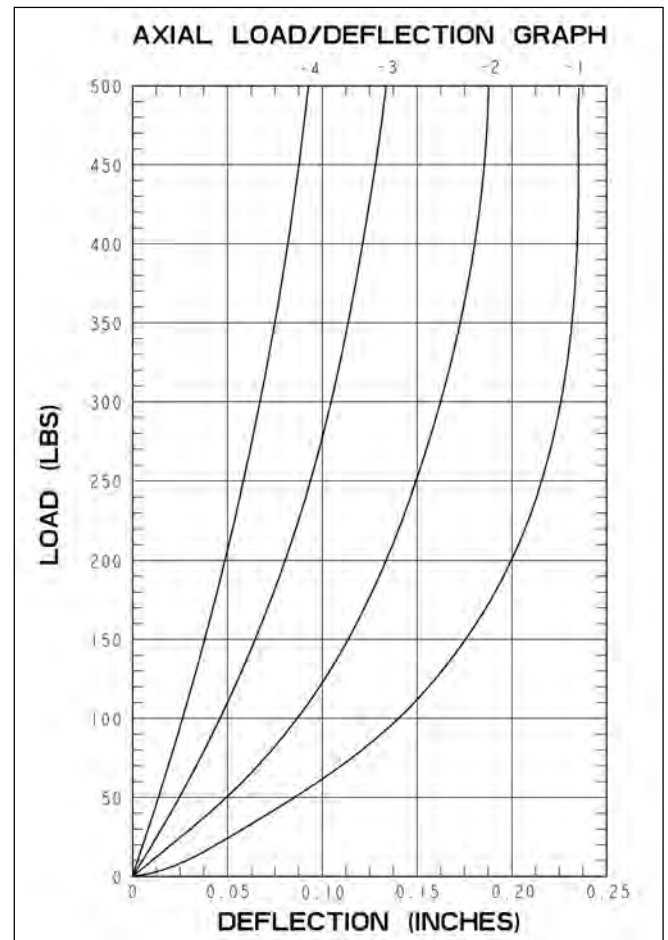
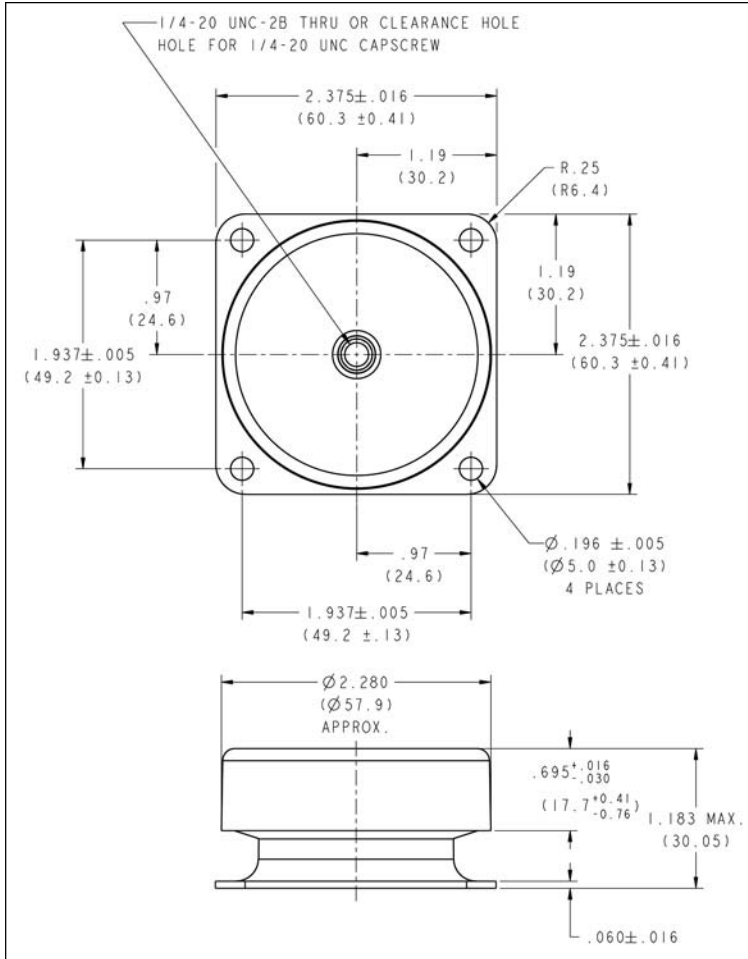

Size 2 Cupmount Series

A compact, universal mount used in the protection of equipment that is exposed to high shock and vibration environments

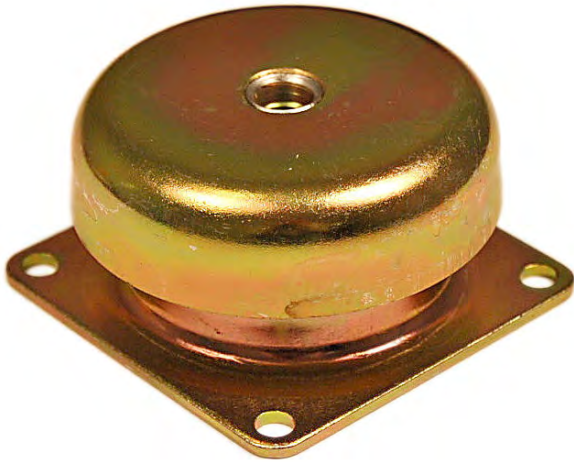

Attributes

- Fail-safe
- All-attitude design
- Compact, low profile design
- Easy to install
- High damped Silicone, Neoprene or Natural Rubber
- Zinc plated steel construction
- Can be used in tandem for higher deflection capability

Applications

- Shipboard equipment
- Mobile platforms
- Avionics
- Rack mounted systems
- Military radios
- Weapons system

Load Range

- 1871-1 = load ratings to 50 lbs./mount max.
- 1871-2 = load ratings to 100 lbs./mount max.
- 1871-3 = load ratings to 150 lbs./mount max.
- 1871-4 = load ratings to 250 lbs./mount max.

Shock & Vibe

- Attenuates a 10g, 11 millisecond half-sine shock to 2 g's
- Survives a 30g, 11 millisecond half-sine
- Passes MIL-STD-167 vibration

Specifications

- Natural Frequency—20-45 Hertz
- Transmissibility at resonance—4 max. (Hi-damp Silicone), 10 max. (Neoprene), 10 max. (Natural Rubber)
- Resilient Element—Hi-damp Silicone, Natural Rubber, Neoprene
- Standard materials—Zinc plated steel
- Weight—Size 2 = 1 lb.

Elastomeric Data

- High-Damp Silicone has an operating temperature of -67°F to $+300^{\circ}\text{F}$ (-55°C to $+150^{\circ}\text{C}$) and is resistant to ozone, fungus and most solvents.
- Other elastomeric formulations are available in BUNA-N, Butyl, Polybutadiene and Neoprene.
- Neoprene has an operating range of -40°F to 200°F (-40°C to $+93^{\circ}\text{C}$) and is used where oil immersion is present.
- Natural Rubber has an operating range of -25°F to $+160^{\circ}\text{F}$ (-37°C to $+70^{\circ}\text{C}$) and is used in high dynamic amplitude environments.

Size 2 Cupmount: 1871

Dimension and Performance Characteristics



Part #	Size	Maximum Load (lbs.)	Load Range Shock lbs.	Free Height	Resilient Material	Structural Material	Core Style	Center Hole	Flange Holes	Transmissibility at Resonance Max.
1871-1SA	2	50	15-30	1.56	Hi-Damp Silicone	Zinc Plated Steel	Threaded	3/8-16 UNC-2B	Ø.266	4:1
1871-2SA	2	100	30-50	1.56	Hi-Damp Silicone	Zinc Plated Steel	Threaded	3/8-16 UNC-2B	Ø.266	4:1
1871-3SA	2	150	50-80	1.56	Hi-Damp Silicone	Zinc Plated Steel	Threaded	3/8-16 UNC-2B	Ø.266	4:1
1871-4SA	2	250	80-105	1.56	Hi-Damp Silicone	Zinc Plated Steel	Threaded	3/8-16 UNC-2B	Ø.266	4:1
1871-1SB	2	50	15-30	1.56	Hi-Damp Silicone	Zinc Plated Steel	Thru Hole	Ø.391	Ø.266	4:1
1871-2SB	2	100	30-50	1.56	Hi-Damp Silicone	Zinc Plated Steel	Thru Hole	Ø.391	Ø.266	4:1
1871-3SB	2	150	50-80	1.56	Hi-Damp Silicone	Zinc Plated Steel	Thru Hole	Ø.391	Ø.266	4:1
1871-4SB	2	250	80-105	1.56	Hi-Damp Silicone	Zinc Plated Steel	Thru Hole	Ø.391	Ø.266	4:1

Part #	Size	Maximum Load (lbs.)	Load Range Shock lbs.	Free Height	Resilient Material	Structural Material	Core Style	Center Hole	Flange Holes	Transmissibility at Resonance Max.
1871-1NA	2	50	15-30	1.56	Neoprene	Zinc Plated Steel	Threaded	3/8-16 UNC-2B	Ø.266	10:1
1871-2NA	2	100	30-50	1.56	Neoprene	Zinc Plated Steel	Threaded	3/8-16 UNC-2B	Ø.266	10:1
1871-3NA	2	150	50-80	1.56	Neoprene	Zinc Plated Steel	Threaded	3/8-16 UNC-2B	Ø.266	10:1
1871-4NA	2	250	80-105	1.56	Neoprene	Zinc Plated Steel	Threaded	3/8-16 UNC-2B	Ø.266	10:1
1871-1NB	2	50	15-30	1.56	Neoprene	Zinc Plated Steel	Thru Hole	Ø.391	Ø.266	10:1
1871-2NB	2	100	30-50	1.56	Neoprene	Zinc Plated Steel	Thru Hole	Ø.391	Ø.266	10:1
1871-3NB	2	150	50-80	1.56	Neoprene	Zinc Plated Steel	Thru Hole	Ø.391	Ø.266	10:1
1871-4NB	2	250	80-105	1.56	Neoprene	Zinc Plated Steel	Thru Hole	Ø.391	Ø.266	10:1

Size 2 Cupmount: 1871

Dimension and Performance Characteristics

Part #	Size	Maximum Load (lbs.)	Load Range Shock lbs.	Free Height	Resilient Material	Structural Material	Core Style	Center Hole	Flange Holes	Transmissibility at Resonance Max.
1871-1NRA	2	50	15-30	1.56	Natural Rubber	Zinc Plated Steel	Threaded	3/8-16 UNC-2B	Ø.266	10:1
1871-2NRA	2	100	30-50	1.56	Natural Rubber	Zinc Plated Steel	Threaded	3/8-16 UNC-2B	Ø.266	10:1
1871-3NRA	2	150	50-80	1.56	Natural Rubber	Zinc Plated Steel	Threaded	3/8-16 UNC-2B	Ø.266	10:1
1871-4NRA	2	250	80-105	1.56	Natural Rubber	Zinc Plated Steel	Threaded	3/8-16 UNC-2B	Ø.266	10:1
1871-1NRB	2	50	15-30	1.56	Natural Rubber	Zinc Plated Steel	Thru Hole	Ø.391	Ø.266	10:1
1871-2NRB	2	100	30-50	1.56	Natural Rubber	Zinc Plated Steel	Thru Hole	Ø.391	Ø.266	10:1
1871-3NRB	2	150	50-80	1.56	Natural Rubber	Zinc Plated Steel	Thru Hole	Ø.391	Ø.266	10:1
1871-4NRB	2	250	80-105	1.56	Natural Rubber	Zinc Plated Steel	Thru Hole	Ø.391	Ø.266	10:1

Size 2 Cupmount: 1871

Dimension and Performance Characteristics

D

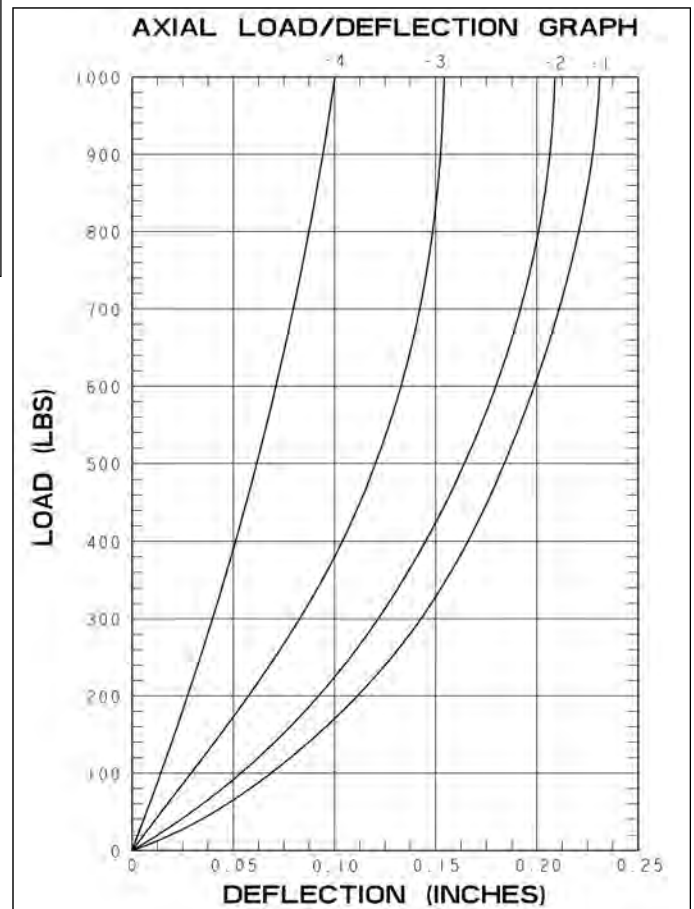
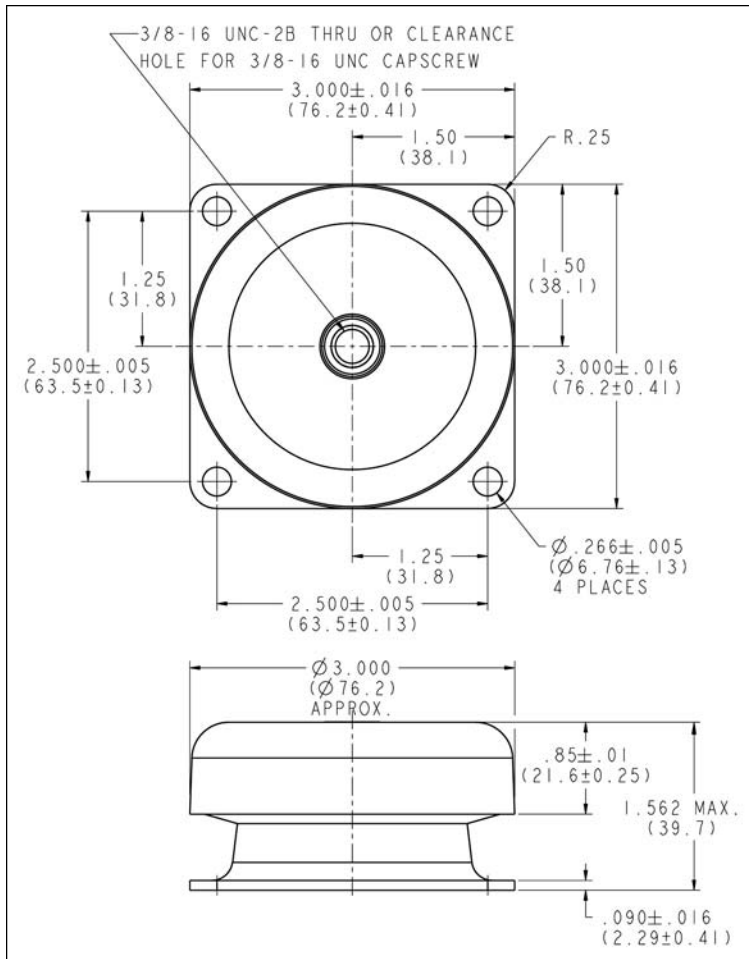

Size 3 Cupmount Series

A compact, universal mount used in the protection of equipment that is exposed to high shock and vibration environments



Attributes

- Fail-safe
- All-attitude design
- Compact, low profile design
- Easy to install
- High damped Silicone, Neoprene or Natural Rubber
- Zinc plated steel construction
- Can be used in tandem for higher deflection capability

Applications

- Shipboard equipment
- Mobile platforms
- Avionics
- Rack mounted systems
- Military radios
- Weapons system

Load Range

- 1872-1 = load ratings to 600 lbs./mount max.
- 1872-2 = load ratings to 800 lbs./mount max.
- 1872-3 = load ratings to 1400 lbs./mount max.
- 1872-4 = load ratings to 1800 lbs./mount max.

Shock & Vibe

- Attenuates a 10g, 11 millisecond half-sine shock to 2 g's
- Survives a 30g, 11 millisecond half-sine
- Passes MIL-STD-167 vibration

Specifications

- Natural Frequency—20-45 Hertz
- Transmissibility at resonance—4 max. (Hi-damp Silicone), 10 max. (Neoprene), 10 max. (Natural Rubber)
- Resilient Element—Hi-damp Silicone, Natural Rubber, Neoprene
- Standard materials—Zinc plated steel
- Weight—Size 3 = 10 lbs.

Elastomeric Data

- High-Damp Silicone has an operating temperature of -67°F to $+300^{\circ}\text{F}$ (-55°C to $+150^{\circ}\text{C}$) and is resistant to ozone, fungus and most solvents.
- Other elastomeric formulations are available in BUNA-N, Butyl, Polybutadiene and Neoprene.
- Neoprene has an operating range of -40°F to 200°F (-40°C to $+93^{\circ}\text{C}$) and is used where oil immersion is present.
- Natural Rubber has an operating range of -25°F to $+160^{\circ}\text{F}$ (-37°C to $+70^{\circ}\text{C}$) and is used in high dynamic amplitude environments.

Size 3 Cupmount: 1872

Dimension and Performance Characteristics



Part #	Size	Maximum Load (lbs.)	Load Range Shock lbs.	Free Height	Resilient Material	Structural Material	Core Style	Center Hole	Flange Holes	Transmissibility at Resonance Max.
1872-1SA	3	600	80-120	3.56	Hi-Damp Silicone	Zinc Plated Steel	Threaded	5/8-11 UNC-2B	Ø.531	4:1
1872-2SA	3	800	120-185	3.56	Hi-Damp Silicone	Zinc Plated Steel	Threaded	5/8-11 UNC-2B	Ø.531	4:1
1872-3SA	3	1400	185-285	3.56	Hi-Damp Silicone	Zinc Plated Steel	Threaded	5/8-11 UNC-2B	Ø.531	4:1
1872-4SA	3	1800	285-530	3.56	Hi-Damp Silicone	Zinc Plated Steel	Threaded	5/8-11 UNC-2B	Ø.531	4:1
1872-1SB	3	600	80-120	3.56	Hi-Damp Silicone	Zinc Plated Steel	Thru Hole	Ø.655	Ø.531	4:1
1872-2SB	3	800	120-185	3.56	Hi-Damp Silicone	Zinc Plated Steel	Thru Hole	Ø.655	Ø.531	4:1
1872-3SB	3	1400	185-285	3.56	Hi-Damp Silicone	Zinc Plated Steel	Thru Hole	Ø.655	Ø.531	4:1
1872-4SB	3	1800	285-530	3.56	Hi-Damp Silicone	Zinc Plated Steel	Thru Hole	Ø.655	Ø.531	4:1

Part #	Size	Maximum Load (lbs.)	Load Range Shock lbs.	Free Height	Resilient Material	Structural Material	Core Style	Center Hole	Flange Holes	Transmissibility at Resonance Max.
1872-1NA	3	600	80-120	3.56	Neoprene	Zinc Plated Steel	Threaded	5/8-11 UNC-2B	Ø.531	10:1
1872-2NA	3	800	120-185	3.56	Neoprene	Zinc Plated Steel	Threaded	5/8-11 UNC-2B	Ø.531	10:1
1872-3NA	3	1400	185-285	3.56	Neoprene	Zinc Plated Steel	Threaded	5/8-11 UNC-2B	Ø.531	10:1
1872-4NA	3	1800	285-530	3.56	Neoprene	Zinc Plated Steel	Threaded	5/8-11 UNC-2B	Ø.531	10:1
1872-1NB	3	600	80-120	3.56	Neoprene	Zinc Plated Steel	Thru Hole	Ø.655	Ø.531	10:1
1872-2NB	3	800	120-185	3.56	Neoprene	Zinc Plated Steel	Thru Hole	Ø.655	Ø.531	10:1
1872-3NB	3	1400	185-285	3.56	Neoprene	Zinc Plated Steel	Thru Hole	Ø.655	Ø.531	10:1
1872-4NB	3	1800	285-530	3.56	Neoprene	Zinc Plated Steel	Thru Hole	Ø.655	Ø.531	10:1

Size 3 Cupmount: 1872

Dimension and Performance Characteristics

Part #	Size	Maximum Load (lbs.)	Load Range Shock lbs.	Free Height	Resilient Material	Structural Material	Core Style	Center Hole	Flange Holes	Transmissibility at Resonance Max.
1872-1NRA	3	600	80-120	3.56	Natural Rubber	Zinc Plated Steel	Threaded	5/8-11 UNC-2B	Ø.531	10:1
1872-2NRA	3	800	120-185	3.56	Natural Rubber	Zinc Plated Steel	Threaded	5/8-11 UNC-2B	Ø.531	10:1
1872-3NRA	3	1400	185-285	3.56	Natural Rubber	Zinc Plated Steel	Threaded	5/8-11 UNC-2B	Ø.531	10:1
1872-4NRA	3	1800	285-530	3.56	Natural Rubber	Zinc Plated Steel	Threaded	5/8-11 UNC-2B	Ø.531	10:1
1872-1NRB	3	600	80-120	3.56	Natural Rubber	Zinc Plated Steel	Thru Hole	Ø.655	Ø.531	10:1
1872-2NRB	3	800	120-185	3.56	Natural Rubber	Zinc Plated Steel	Thru Hole	Ø.655	Ø.531	10:1
1872-3NRB	3	1400	185-285	3.56	Natural Rubber	Zinc Plated Steel	Thru Hole	Ø.655	Ø.531	10:1
1872-4NRB	3	1800	285-530	3.56	Natural Rubber	Zinc Plated Steel	Thru Hole	Ø.655	Ø.531	10:1

Size 3 Cupmount: 1872

Dimension and Performance Characteristics

D

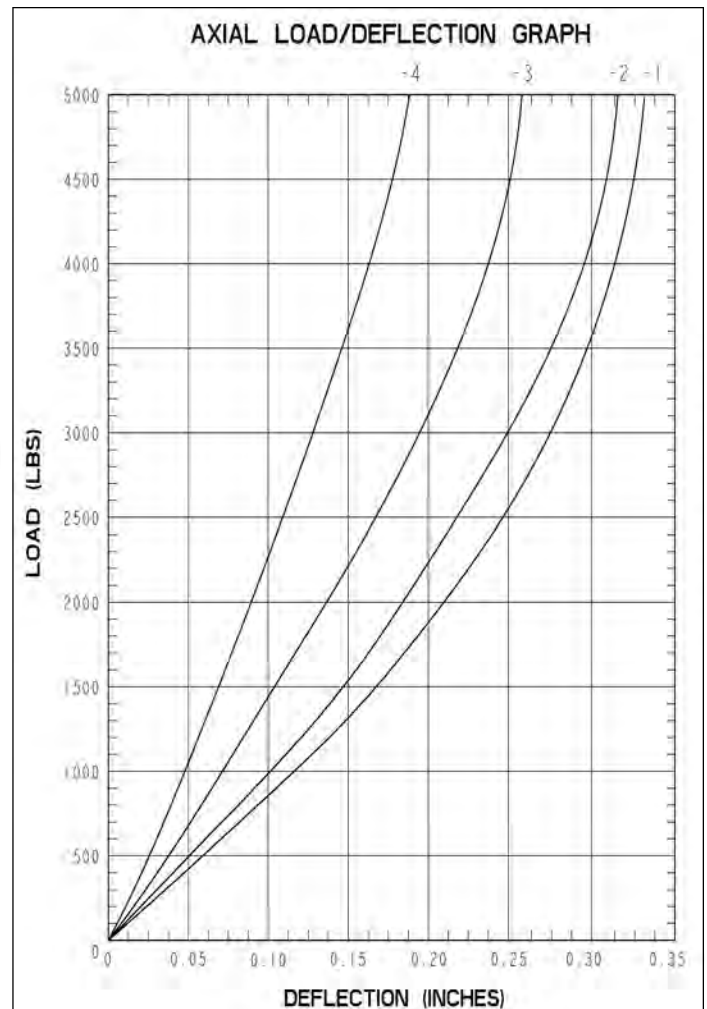
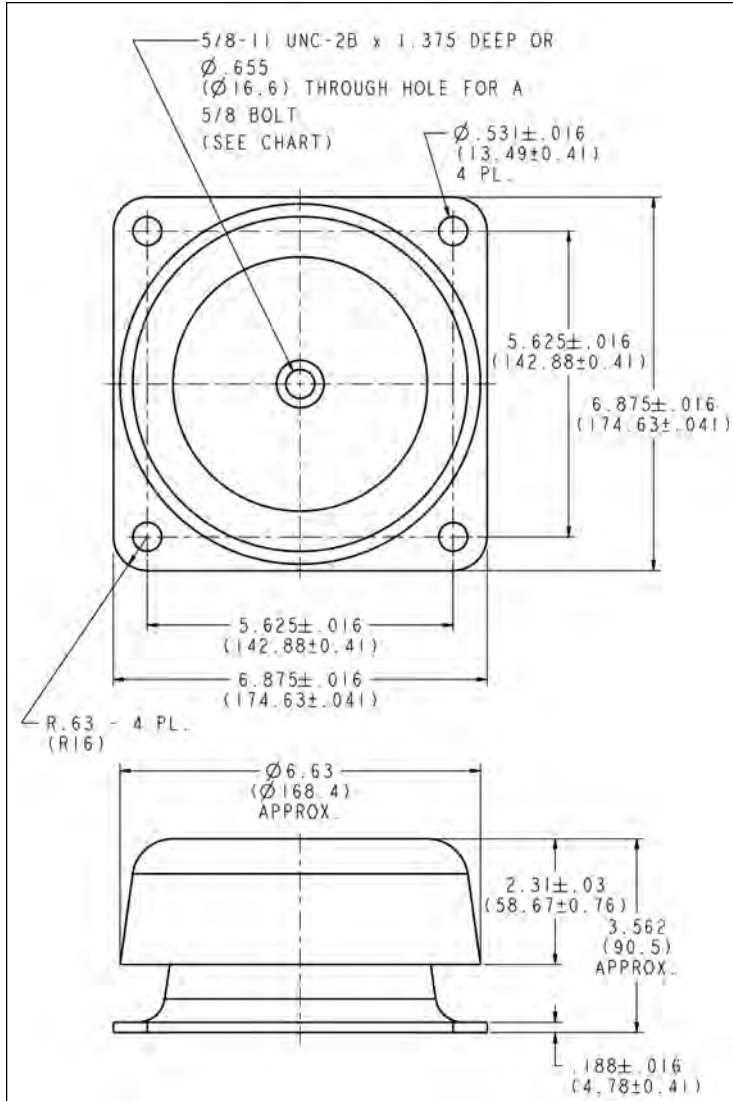

Size 4 Cupmount Series

A compact, universal mount used in the protection of equipment that is exposed to high shock and vibration environments



Attributes

- Fail-safe
- All-attitude design
- Compact, low profile design
- Easy to install
- High damped Silicone, Neoprene or Natural Rubber
- Zinc plated steel construction
- Can be used in tandem for higher deflection capability

Applications

- Shipboard equipment
- Mobile platforms
- Avionics
- Rack mounted systems
- Military radios
- Weapons system

Load Range

- 1873-1 = load ratings to 250 lbs./mount max.
- 1873-2 = load ratings to 400 lbs./mount max.
- 1873-3 = load ratings to 650 lbs./mount max.
- 1873-4 = load ratings to 900 lbs./mount max.

Shock & Vibe

- Attenuates a 10g, 11 millisecond half-sine shock to 2 g's
- Survives a 30g, 11 millisecond half-sine
- Passes MIL-STD-167 vibration

Specifications

- Natural Frequency—20-45 Hertz
- Transmissibility at resonance—4 max. (Hi-damp Silicone), 10 max. (Neoprene), 10 max. (Natural Rubber)
- Resilient Element—Hi-damp Silicone, Natural Rubber, Neoprene
- Standard materials—Zinc plated steel
- Weight—Size 4 = 4 lbs.

Elastomeric Data

- High-Damp Silicone has an operating temperature of -67°F to $+300^{\circ}\text{F}$ (-55°C to $+150^{\circ}\text{C}$) and is resistant to ozone, fungus and most solvents.
- Other elastomeric formulations are available in BUNA-N, Butyl, Polybutadiene and Neoprene.
- Neoprene has an operating range of -40°F to 200°F (-40°C to $+93^{\circ}\text{C}$) and is used where oil immersion is present.
- Natural Rubber has an operating range of -25°F to $+160^{\circ}\text{F}$ (-37°C to $+70^{\circ}\text{C}$) and is used in high dynamic amplitude environments.

Size 4 Cupmount: 1873

Dimension and Performance Characteristics



Part #	Size	Maximum Load (lbs.)	Load Range Shock lbs.	Free Height	Resilient Material	Structural Material	Core Style	Center Hole	Flange Holes	Transmissibility at Resonance Max.
1873-1SA	4	250	65-100	2.63	Hi-Damp Silicone	Zinc Plated Steel	Threaded	5/8-11 UNC-2B	Ø.469	4:1
1873-2SA	4	400	100-155	2.63	Hi-Damp Silicone	Zinc Plated Steel	Threaded	5/8-11 UNC-2B	Ø.469	4:1
1873-3SA	4	650	155-200	2.63	Hi-Damp Silicone	Zinc Plated Steel	Threaded	5/8-11 UNC-2B	Ø.469	4:1
1873-4SA	4	900	200-285	2.63	Hi-Damp Silicone	Zinc Plated Steel	Threaded	5/8-11 UNC-2B	Ø.469	4:1
1873-1SB	4	250	65-100	2.63	Hi-Damp Silicone	Zinc Plated Steel	Thru Hole	Ø.655	Ø.469	4:1
1873-2SB	4	400	100-155	2.63	Hi-Damp Silicone	Zinc Plated Steel	Thru Hole	Ø.655	Ø.469	4:1
1873-3SB	4	650	155-200	2.63	Hi-Damp Silicone	Zinc Plated Steel	Thru Hole	Ø.655	Ø.469	4:1
1873-4SB	4	900	200-285	2.63	Hi-Damp Silicone	Zinc Plated Steel	Thru Hole	Ø.655	Ø.469	4:1

Part #	Size	Maximum Load (lbs.)	Load Range Shock lbs.	Free Height	Resilient Material	Structural Material	Core Style	Center Hole	Flange Holes	Transmissibility at Resonance Max.
1873-1NA	4	250	65-100	2.63	Neoprene	Zinc Plated Steel	Threaded	5/8-11 UNC-2B	Ø.469	10:1
1873-2NA	4	400	100-155	2.63	Neoprene	Zinc Plated Steel	Threaded	5/8-11 UNC-2B	Ø.469	10:1
1873-3NA	4	650	155-200	2.63	Neoprene	Zinc Plated Steel	Threaded	5/8-11 UNC-2B	Ø.469	10:1
1873-4NA	4	900	200-285	2.63	Neoprene	Zinc Plated Steel	Threaded	5/8-11 UNC-2B	Ø.469	10:1
1873-1NB	4	250	65-100	2.63	Neoprene	Zinc Plated Steel	Thru Hole	Ø.655	Ø.469	10:1
1873-2NB	4	400	100-155	2.63	Neoprene	Zinc Plated Steel	Thru Hole	Ø.655	Ø.469	10:1
1873-3NB	4	650	155-200	2.63	Neoprene	Zinc Plated Steel	Thru Hole	Ø.655	Ø.469	10:1
1873-4NB	4	900	200-285	2.63	Neoprene	Zinc Plated Steel	Thru Hole	Ø.655	Ø.469	10:1

Size 4 Cupmount: 1873

Dimension and Performance Characteristics

Part #	Size	Maximum Load (lbs.)	Load Range Shock lbs.	Free Height	Resilient Material	Structural Material	Core Style	Center Hole	Flange Holes	Transmissibility at Resonance Max.
1873-1NRA	4	250	65-100	2.63	Natural Rubber	Zinc Plated Steel	Threaded	5/8-11 UNC-2B	Ø.469	10:1
1873-2NRA	4	400	100-155	2.63	Natural Rubber	Zinc Plated Steel	Threaded	5/8-11 UNC-2B	Ø.469	10:1
1873-3NRA	4	650	155-200	2.63	Natural Rubber	Zinc Plated Steel	Threaded	5/8-11 UNC-2B	Ø.469	10:1
1873-4NRA	4	900	200-285	2.63	Natural Rubber	Zinc Plated Steel	Threaded	5/8-11 UNC-2B	Ø.469	10:1
1873-1NRB	4	250	65-100	2.63	Natural Rubber	Zinc Plated Steel	Thru Hole	Ø.655	Ø.469	10:1
1873-2NRB	4	400	100-155	2.63	Natural Rubber	Zinc Plated Steel	Thru Hole	Ø.655	Ø.469	10:1
1873-3NRB	4	650	155-200	2.63	Natural Rubber	Zinc Plated Steel	Thru Hole	Ø.655	Ø.469	10:1
1873-4NRB	4	900	200-285	2.63	Natural Rubber	Zinc Plated Steel	Thru Hole	Ø.655	Ø.469	10:1

Size 4 Cupmount: 1873

Dimension and Performance Characteristics

D

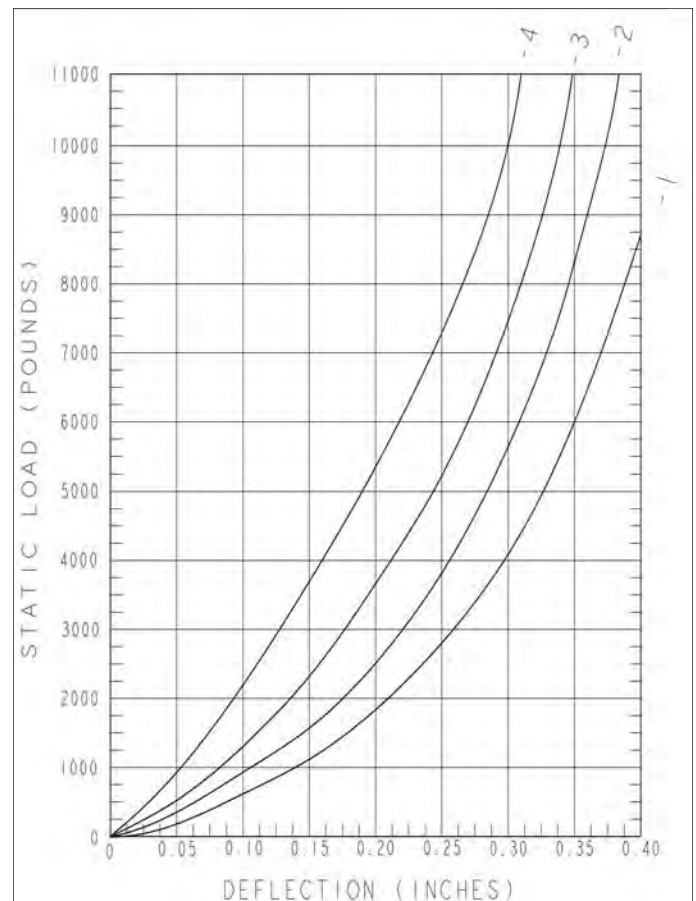
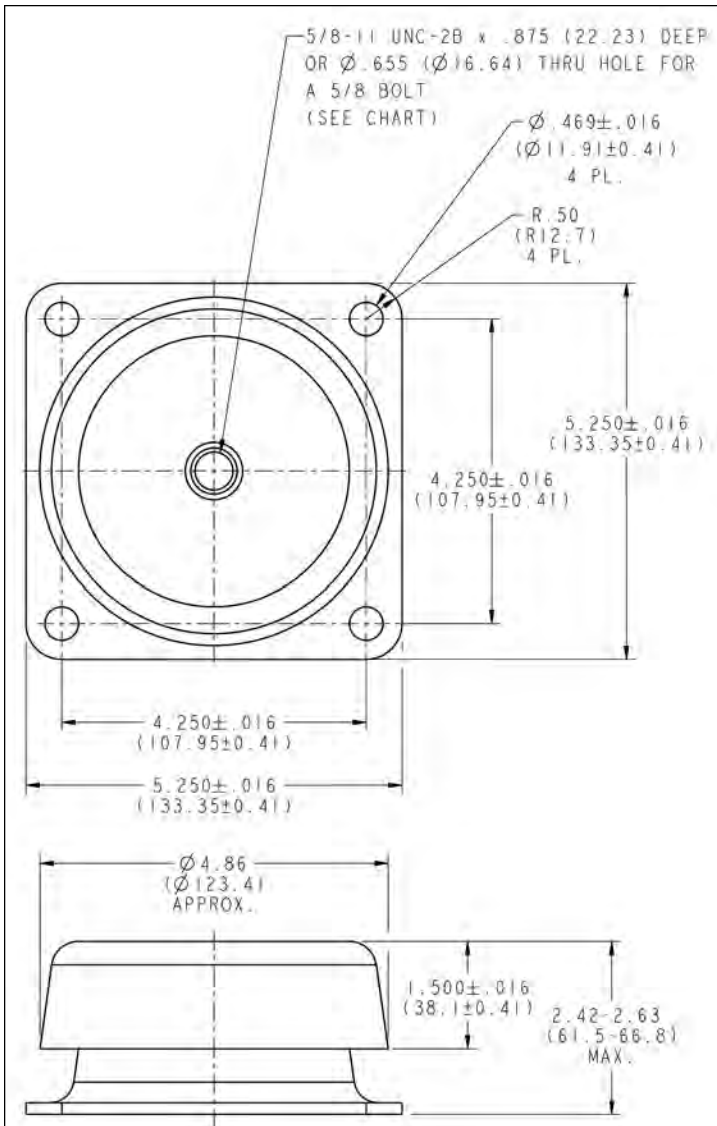

CYLINDRICAL MOUNT SERIES

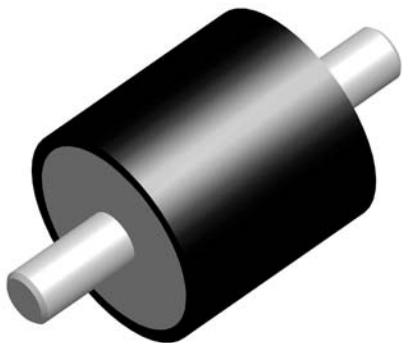
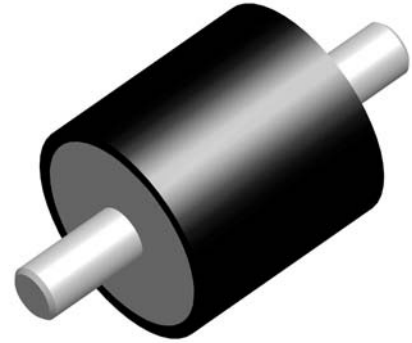

Cylindrical Mount Series

Industry standard easy to install, low-cost stud type mounts for vibration, shock and motion accommodation

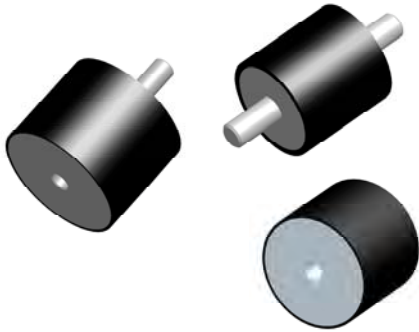

Attributes

- Easy to install
- Low-cost
- Numerous configuration
- Compact

How to order cylindrical mounts

EP1000-101-2-N

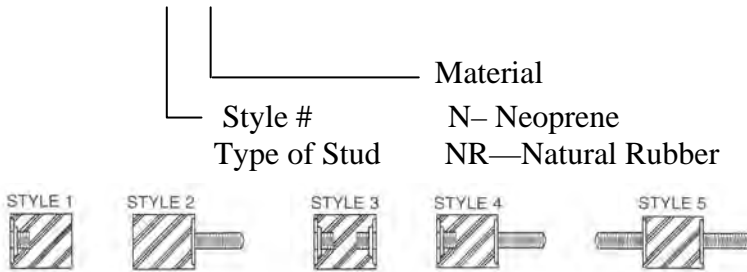

Applications

- Small industrial equipment
- HVAC equipment
- Business equipment
- Air compressors (no mobile)

Benefits

- Simple design and sturdy construction permit their use in a wide variety of industrial applications

Load Range Axial Compression

- EP1000 = load ratings from 3.0—27.2 lbs.
- EP1100 = load ratings from 2.5—45 lbs.
- EP1105 = load ratings from 5.0—18 lbs.
- EP1200 = load ratings from 6.0—92 lbs.
- EP1300 = load ratings from 9.2—380 lbs.
- EP1400 = load ratings from 20—220 lbs.
- EP1500 = load ratings from 37—560 lbs.
- EP1600 = load ratings from 44—180 lbs.
- EP1700 = load ratings from 110—230 lbs.
- EP1830 = load ratings from 80—400 lbs.
- EP1810 = load ratings from 60—780 lbs.

Specifications

- Natural Frequency—10-30 Hertz
- Transmissibility at resonance—10:1
- Resilient Element—Neoprene and Natural Rubber
- Materials—Low carbon steel, zinc plate

Elastomeric Data

- Neoprene elastomer has an operating temperature range of -40°F to 200°F (-40°C to $+93^{\circ}\text{C}$) and is resistant to oils, most solvents and ozone
- Natural Rubber has an operating temperature range of -25°F to $+160^{\circ}\text{F}$ (-37°C to $+70^{\circ}\text{C}$)
- Other materials are available on special order to meet specific operating characteristics

E

Cylindrical Mount Series: 6-32 Threads

*Ordering example: EP1000-101-(5)-(N) = 3/8 dia x 5/16 long, 3 lbs. load, Style 5, Neoprene

PART NUMBER	STYLES AVAILABLE	DIA (in.)	T (in.)	STANDARD STUD LENGTH (in.)	MAXIMUM STATIC LOAD (lbs.)	
					Shear	Compression
EP1000-101-(-)(-)	2,4,5	3/8	5/16	3/8	.5	3.0
EP1000-102-(-)(-)					.7	4.0
EP1000-103-(-)(-)					1.0	5.0
EP1000-104-(-)(-)					1.2	6.0
EP1000-105-(-)(-)					1.5	7.0
EP1000-121-(-)(-)	2,4,5	7/16	7/16	3/8	2.0	4.2
EP1000-122-(-)(-)					2.9	5.7
EP1000-123-(-)(-)					4.2	8.5
EP1000-124-(-)(-)					5.8	10.4
EP1000-125-(-)(-)					6.9	11.9
EP1000-131-(-)(-)	2,4,5	7/16	1/2	3/8	2.7	4.9
EP1000-132-(-)(-)					3.6	6.4
EP1000-133-(-)(-)					5.6	10.4
EP1000-134-(-)(-)					6.4	13.3
EP1000-135-(-)(-)					7.4	15.8
EP1000-141-(-)(-)	2,4,5	1/2	1/2	3/8	3.6	6.5
EP1000-142-(-)(-)					4.5	9.2
EP1000-143-(-)(-)					7.3	13.2
EP1000-144-(-)(-)					9.2	19.3
EP1000-145-(-)(-)					11.2	27.2

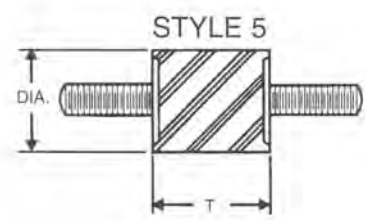
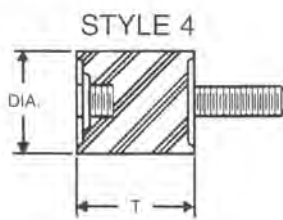
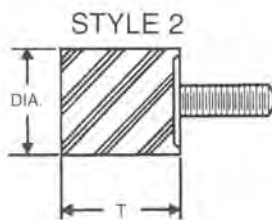

AVAILABLE IN NATURAL AND NEOPRENE

NON STANDARD STUD LENGTHS AVAILABLE

Cylindrical Mount Series: 8-32 Threads

*Ordering example: EP1100-101-(5)-(NR) = 3/8 dia x 1/4 long, 3 lbs. load, Style 5, Natural Rubber

E

PART NUMBER	STYLES AVAILABLE	DIA (in.)	T (in.)	STANDARD STUD LENGTH (in.)	MAXIMUM STATIC LOAD (lbs.)	
					Shear	Compression
EP1100-101-(-)-(-)	1, 2, 4, 5	3/8	1/4	3/8	.5	3.0
EP1100-102-(-)-(-)					.7	4.0
EP1100-103-(-)-(-)					1.0	5.0
EP1100-104-(-)-(-)					1.2	6.0
EP1100-105-(-)-(-)					1.5	7.0
EP1100-106-(-)-(-)	2, 5	3/8	5/32	3/8	.3	2.5
EP1100-107-(-)-(-)					.5	3.5
EP1100-108-(-)-(-)					.8	4.5
EP1100-109-(-)-(-)					1.0	5.5
EP1100-110-(-)-(-)					1.2	6.5
EP1100-111-(-)-(-)	1, 2, 4, 5	3/8	1/2	3/8	.8	4.5
EP1100-112-(-)-(-)					1.2	6.2
EP1100-113-(-)-(-)					1.7	8.0
EP1100-114-(-)-(-)					1.9	9.5
EP1100-115-(-)-(-)					2.3	10.9
EP1100-116-(-)-(-)	2, 5	3/8	5/16	3/8	.5	3.0
EP1100-117-(-)-(-)					.7	4.0
EP1100-118-(-)-(-)					1.0	5.0
EP1100-119-(-)-(-)					1.2	6.0
EP1100-120-(-)-(-)					1.5	7.0

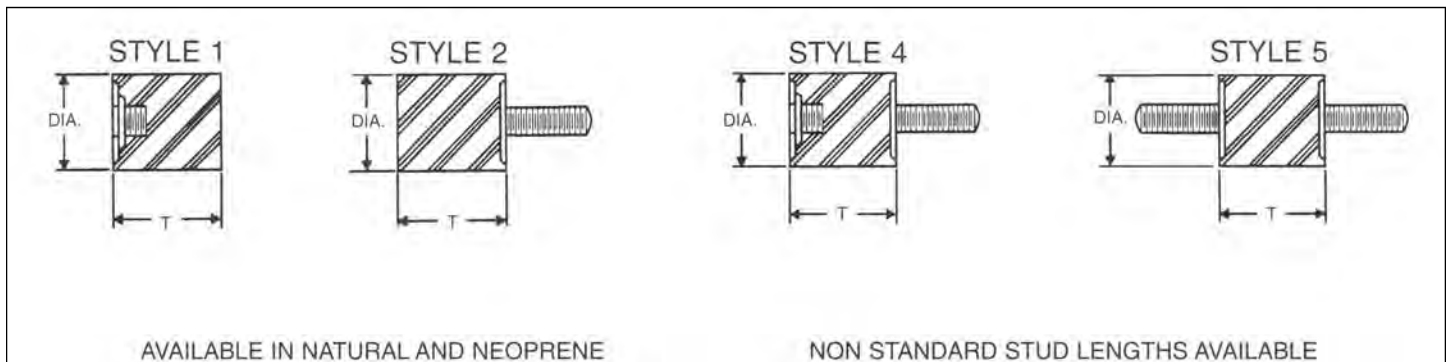

Cylindrical Mount Series: 8-32 Threads

*Ordering example: EP1100-121-(5)-(N) = 7/16 dia x 1/2 long, 4.9 lbs. load, Style 5, Neoprene

PART NUMBER	STYLES AVAILABLE	DIA (in.)	T (in.)	STANDARD STUD LENGTH (in.)	MAXIMUM STATIC LOAD (lbs.)	
					Shear	Compression
EP1100-121-(-)(-)	1, 2, 3, 4, 5	7/16	1/2	3/8	2.7	4.9
EP1100-122-(-)(-)					3.6	6.4
EP1100-123-(-)(-)					5.6	10.4
EP1100-124-(-)(-)					6.4	13.3
EP1100-125-(-)(-)					7.4	15.8
EP1100-126-(-)(-)	1, 2, 3, 4, 5	1/2	3/4	3/8	8.5	22.0
EP1100-127-(-)(-)					12.0	29.0
EP1100-128-(-)(-)					16.0	35.0
EP1100-129-(-)(-)					20.0	40.0
EP1100-130-(-)(-)					25.0	45.0
EP1100-131-(-)(-)	1, 2, 3, 4, 5	9/16	1/2	3/8	4.4	8.0
EP1100-132-(-)(-)					6.7	12.0
EP1100-133-(-)(-)					9.0	16.0
EP1100-134-(-)(-)					12.0	25.0
EP1100-135-(-)(-)					15.0	33.0
EP1100-136-(-)(-)	1, 2, 3, 4, 5	9/16	.66	3/8	4.2	7.8
EP1100-137-(-)(-)					6.3	11.5
EP1100-138-(-)(-)					8.5	15.3
EP1100-139-(-)(-)					11.4	22.2
EP1100-140-(-)(-)					14.1	45.0

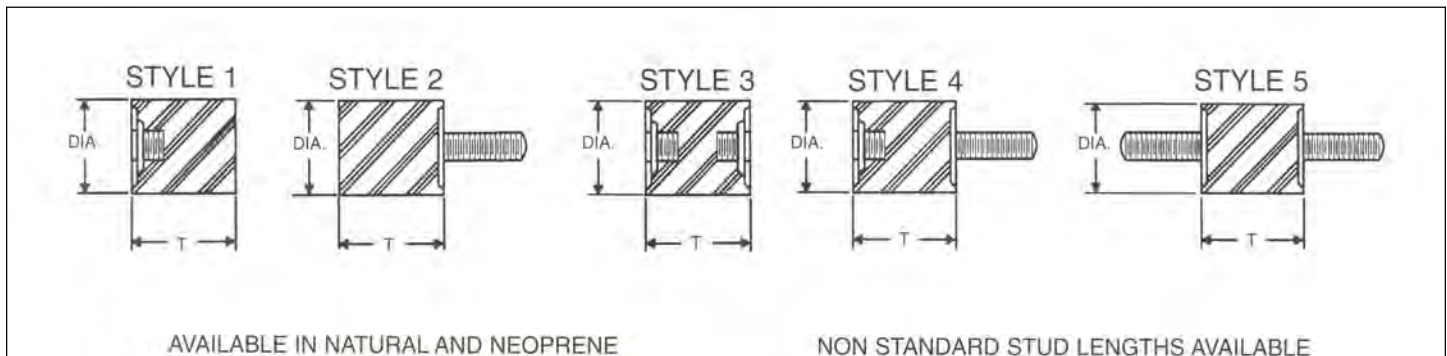

Cylindrical Mount Series: 8-32 Threads

*Ordering example: EP1100-141-(5)-(N) = 9/16 dia x 3/4 long, 22 lbs. load, Style 5, Neoprene

E

PART NUMBER	STYLES AVAILABLE	DIA (in.)	T (in.)	STANDARD STUD LENGTH (in.)	MAXIMUM STATIC LOAD (lbs.)	
					Shear	Compression
EP1100-141-(-)(-)	1, 2, 3, 4, 5	9/16	3/4	3/8	8.5	22.0
EP1100-142-(-)(-)					12.0	29.0
EP1100-143-(-)(-)					16.0	35.0
EP1100-144-(-)(-)					20.0	40.0
EP1100-145-(-)(-)					25.0	45.0
EP1100-146-(-)(-)	1, 2, 3, 4, 5	7/16	7/16	3/8	2.0	4.2
EP1100-147-(-)(-)					2.9	5.7
EP1100-148-(-)(-)					4.2	8.5
EP1100-149-(-)(-)					5.8	10.4
EP1100-150-(-)(-)					6.9	11.9
EP1100-151-(-)(-)	1, 2, 3, 4, 5	5/8	1/2	3/8	4.6	9.0
EP1100-152-(-)(-)					6.8	13.0
EP1100-153-(-)(-)					9.5	17.0
EP1100-154-(-)(-)					13.0	26.0
EP1100-155-(-)(-)					15.0	31.0
EP1100-161-(-)(-)	1, 2, 3, 4, 5	3/4	1/2	3/8	8.0	22.0
EP1100-162-(-)(-)					11.0	29.0
EP1100-163-(-)(-)					15.0	35.0
EP1100-164-(-)(-)					18.0	18.0
EP1100-165-(-)(-)					21.0	21.0

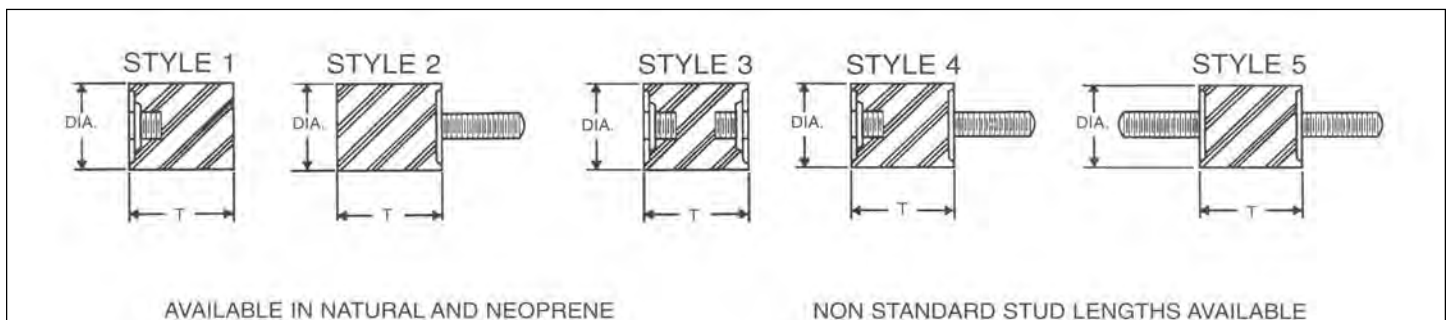

Rectangular Mount Series: 8-32 Threads

*Ordering example: EP1105-801-(N) = 5/16 long, 6.5 lbs. load, Neoprene

PART NUMBER	SQ (square) (in.)	T (in.)	STANDARD STUD LENGTH (in.)	MAXIMUM STATIC LOAD (lbs.)	
				Shear	Compression
EP1105-801-(-)	3/8	5/16	7/32	4.5	6.5
EP1105-802-(-)	3/8	5/16	7/32	5.5	9.0
EP1105-803-(-)	3/8	5/16	7/32	8.0	12.0
EP1105-804-(-)	3/8	5/16	7/32	10.0	15.5
EP1105-805-(-)	3/8	5/16	7/32	12.5	18.0
EP1105-811-(-)	3/8	1/2	3/8	2.5	5.0
EP1105-812-(-)	3/8	1/2	3/8	3.5	6.5
EP1105-813-(-)	3/8	1/2	3/8	5.5	11.0
EP1105-814-(-)	3/8	1/2	3/8	7.0	14.0
EP1105-815-(-)	3/8	1/2	3/8	8.5	17.0



AVAILABLE IN NATURAL AND NEOPRENE

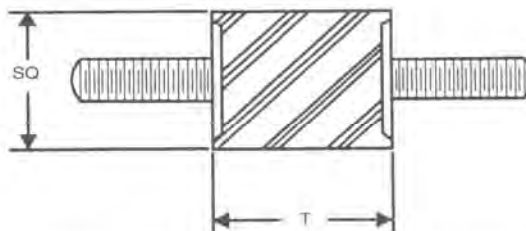

NON STANDARD STUD LENGTHS AVAILABLE

Cylindrical Mount Series: 10-32 Threads

*Ordering example: EP1200-101-(5)-(N) = 9/16 dia x 1/2 long, 8 lbs. load, Style 5, Neoprene

E

PART NUMBER	STYLES AVAILABLE	DIA (in.)	T (in.)	STANDARD STUD LENGTH (in.)	MAXIMUM STATIC LOAD (lbs.)	
					Shear	Compression
EP1200-101-(-)-(-)	2, 4, 5	9/16	1/2	3/8	4.4	8.0
EP1200-102-(-)-(-)					6.7	12.0
EP1200-103-(-)-(-)					9.4	16.0
EP1200-104-(-)-(-)					12.0	25.0
EP1200-105-(-)-(-)					15.0	33.0
EP1200-106-(-)-(-)	2, 5	9/16	5/16	3/8	3.0	6.0
EP1200-107-(-)-(-)					5.2	8.0
EP1200-108-(-)-(-)					7.0	12.0
EP1200-109-(-)-(-)					9.0	19.0
EP1200-110-(-)-(-)					11.0	27.0
EP1200-121-(-)-(-)	2, 4, 5	3/4	5/8	3/8	9.0	23.0
EP1200-122-(-)-(-)					12.0	30.0
EP1200-123-(-)-(-)					16.0	37.0
EP1200-124-(-)-(-)					18.5	41.0
EP1200-125-(-)-(-)					21.0	45.5
EP1200-131-(-)-(-)	2, 5	1	3/8	3/8	8.5	21.0
EP1200-132-(-)-(-)					1.2	31.0
EP1200-133-(-)-(-)					17.5	36.5
EP1200-134-(-)-(-)					18.0	40.0
EP1200-135-(-)-(-)					22.0	46.0
EP1200-141-(-)-(-)	2, 4, 5	1	3/4	3/8	18.0	35.0
EP1200-142-(-)-(-)					25.0	45.0
EP1200-143-(-)-(-)					34.0	60.0
EP1200-144-(-)-(-)					40.0	80.0
EP1200-145-(-)-(-)					48.0	92.0

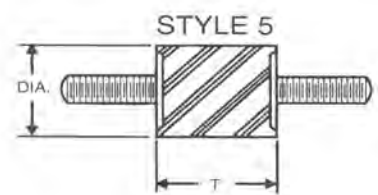
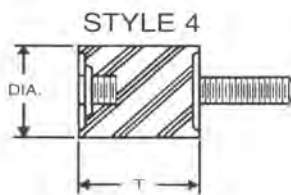
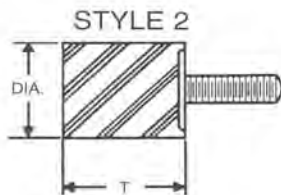

AVAILABLE IN NATURAL AND NEOPRENE

NON STANDARD STUD LENGTHS AVAILABLE

Cylindrical Mount Series: 1/4-20 Threads

*Ordering example: EP1300-101-(5)-(N) = 5/8 dia x 5/8 long, 9.2 lbs. load, Style 5, Neoprene

PART NUMBER	STYLES AVAILABLE	DIA (in.)	T (in.)	STANDARD STUD LENGTH (in.)	MAXIMUM STATIC LOAD (lbs.)	
					Shear	Compression
EP1300-101-(-)(-)	1, 2, 4, 5	5/8	5/8	1/2	5.2	9.2
EP1300-102-(-)(-)					7.3	13.1
EP1300-103-(-)(-)					10.1	17.0
EP1300-104-(-)(-)					13.2	24.0
EP1300-105-(-)(-)					14.0	28.0
EP1300-111-(-)(-)	2, 4, 5	3/4	3/8	1/2	8.5	22.0
EP1300-112-(-)(-)					12.0	29.0
EP1300-113-(-)(-)					16.0	35.0
EP1300-114-(-)(-)					20.0	40.0
EP1300-115-(-)(-)					25.0	45.0
EP1300-116-(-)(-)	2, 4, 5	1	1/4	1/2	10.0	22.0
EP1300-117-(-)(-)					12.5	32.0
EP1300-118-(-)(-)					17.0	36.5
EP1300-119-(-)(-)					19.5	43.0
EP1300-120-(-)(-)					21.0	46.5
EP1300-121-(-)(-)	1, 2, 4, 5	3/4	1/2	1/2	8.5	22.0
EP1300-122-(-)(-)					13.0	30.0
EP1300-123-(-)(-)					16.5	36.0
EP1300-124-(-)(-)					19.2	42.5
EP1300-125-(-)(-)					26.5	47.0
EP1300-126-(-)(-)	2, 5	1	3/8	1/2	9.0	20.0
EP1300-127-(-)(-)					11.5	30.0
EP1300-128-(-)(-)					15.5	35.0
EP1300-129-(-)(-)					18.0	41.0
EP1300-130-(-)(-)					20.5	45.0

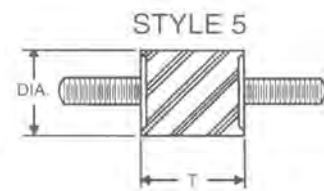
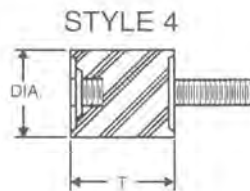
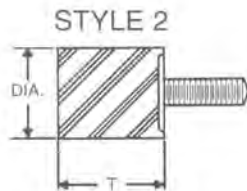
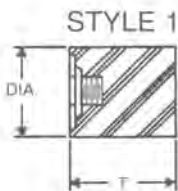

AVAILABLE IN NATURAL AND NEOPRENE

NON STANDARD STUD LENGTHS AVAILABLE

Cylindrical Mount Series: 1/4-20 Threads

*Ordering example: EP1300-131-(5)-(N) = 3/4 dia x 5/8 long, 23 lbs. load, Style 5, Neoprene

E

PART NUMBER	STYLES AVAILABLE	DIA (in.)	T (in.)	STANDARD STUD LENGTH (in.)	MAXIMUM STATIC LOAD (lbs.)	
					Shear	Compression
EP1300-131-(-)(-)	1, 2, 4, 5	3/4	5/8	1/2	9.0	23.0
EP1300-132-(-)(-)					12.0	30.0
EP1300-133-(-)(-)					16.0	37.0
EP1300-134-(-)(-)					18.5	41.0
EP1300-135-(-)(-)					21.0	45.5
EP1300-136-(-)(-)	1, 2, 4, 5	3/4	3/4	1/2	9.5	24.0
EP1300-137-(-)(-)					14.0	32.0
EP1300-138-(-)(-)					18.0	38.0
EP1300-139-(-)(-)					21.0	45.0
EP1300-140-(-)(-)					28.5	50.0
EP1300-141-(-)(-)	1, 2, 4, 5	3/4	1	1/2	8.0	22.5
EP1300-142-(-)(-)					12.5	30.5
EP1300-143-(-)(-)					17.0	36.5
EP1300-144-(-)(-)					20.0	43.0
EP1300-145-(-)(-)					27.0	48.5
EP1300-146-(-)(-)	1, 2, 4, 5	1	17/32	1/2	19.0	40.0
EP1300-147-(-)(-)					21.0	43.0
EP1300-148-(-)(-)					37.0	74.0
EP1300-149-(-)(-)					42.0	175.0
EP1300-150-(-)(-)					49.0	380.0
EP1300-151-(-)(-)	1, 2, 4, 5	1	3/4	1/2	18.0	35.0
EP1300-152-(-)(-)					25.0	45.0
EP1300-153-(-)(-)					34.0	60.0
EP1300-154-(-)(-)					40.0	80.0
EP1300-155-(-)(-)					45.0	88.0

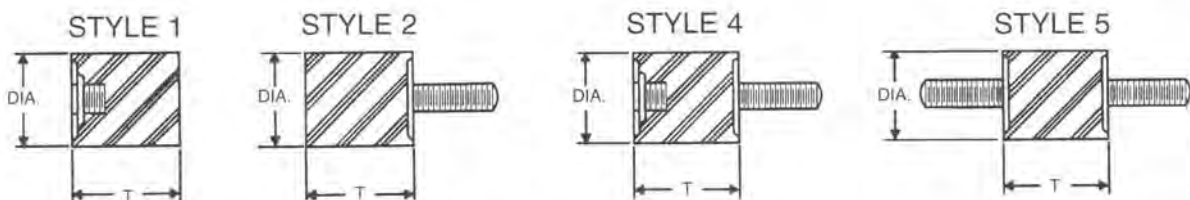

AVAILABLE IN NATURAL AND NEOPRENE

NON STANDARD STUD LENGTHS AVAILABLE

Cylindrical Mount Series: 1/4-20 Threads

*Ordering example: EP1300-156-(5)-(N) = 1" dia x 5/8 long, 37.5 lbs. load, Style 5, Neoprene

PART NUMBER	STYLES AVAILABLE	DIA (in.)	T (in.)	STANDARD STUD LENGTH (in.)	MAXIMUM STATIC LOAD (lbs.)	
					Shear	Compression
EP1300-156-(-)(-)	1, 2, 4, 5	1	5/8	1/2	18.5	37.5
EP1300-157-(-)(-)					23.0	44.0
EP1300-158-(-)(-)					35.0	57.0
EP1300-159-(-)(-)					41.0	77.0
EP1300-160-(-)(-)					47.0	84.0
EP1300-161-(-)(-)	1, 2, 4, 5	1	1	1/2	15.0	37.0
EP1300-162-(-)(-)					23.0	50.0
EP1300-163-(-)(-)					35.0	62.0
EP1300-164-(-)(-)					43.0	85.0
EP1300-165-(-)(-)					48.0	91.0
EP1300-166-(-)(-)	1, 2, 4, 5	1	1 1/4	1/2	13.0	34.5
EP1300-167-(-)(-)					21.5	48.0
EP1300-168-(-)(-)					33.0	60.0
EP1300-169-(-)(-)					41.0	83.5
EP1300-170-(-)(-)					46.5	89.0
EP1300-171-(-)(-)	1, 2, 4, 5	1 1/4	3/4	1/2	30.0	55.0
EP1300-172-(-)(-)					40.0	75.0
EP1300-173-(-)(-)					50.0	100
EP1300-174-(-)(-)					60.0	140
EP1300-175-(-)(-)					70.0	160
EP1300-176-(-)(-)	1, 2, 4, 5	1 1/4	1	1/2	32.0	56.0
EP1300-177-(-)(-)					37.0	82.0
EP1300-178-(-)(-)					48.0	115
EP1300-179-(-)(-)					63.0	123
EP1300-180-(-)(-)					72.0	130

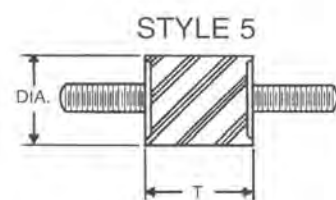
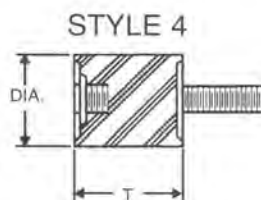
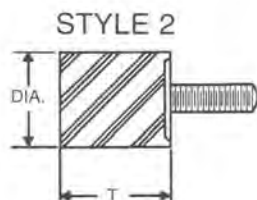
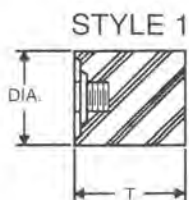

AVAILABLE IN NATURAL AND NEOPRENE

NON STANDARD STUD LENGTHS AVAILABLE

Cylindrical Mount Series: 5/16-18 Threads

*Ordering example: EP1400-091-(5)-(N) = 3/4 dia x 1" long, 25 lbs. load, Style 5, Neoprene

E

PART NUMBER	STYLES AVAILABLE	DIA (in.)	T (in.)	STANDARD STUD LENGTH (in.)	MAXIMUM STATIC LOAD (lbs.)	
					Shear	Compression
EP1400-091-(-)(-)	1, 2, 4, 5	3/4	1	1/2	10.0	25.0
EP1400-092-(-)(-)					13.0	30.0
EP1400-093-(-)(-)					15.8	39.0
EP1400-094-(-)(-)					22.0	47.0
EP1400-095-(-)(-)					31.0	59.0
EP1400-096-(-)(-)	1, 2, 4, 5	3/4	5/8	1/2	9.0	23.0
EP1400-097-(-)(-)					12.0	30.0
EP1400-098-(-)(-)					16.0	37.0
EP1400-099-(-)(-)					18.5	41.0
EP1400-100-(-)(-)					21.0	45.5
EP1400-101-(-)(-)	1, 2, 5	1	5/8	1/2	19.0	37.0
EP1400-102-(-)(-)					23.5	44.5
EP1400-103-(-)(-)					35.5	56.0
EP1400-104-(-)(-)					41.0	77.0
EP1400-105-(-)(-)					47.5	84.0
EP1400-106-(-)(-)	1, 2, 4, 5	1	17/32	1/2	20.0	39.0
EP1400-107-(-)(-)					22.0	44.0
EP1400-108-(-)(-)					37.0	54.0
EP1400-109-(-)(-)					42.0	74.0
EP1400-110-(-)(-)					50.0	80.0
EP1400-111-(-)(-)	1, 2, 4, 5	1	3/4	1/2	18.0	35.0
EP1400-112-(-)(-)					25.0	45.0
EP1400-113-(-)(-)					34.0	60.0
EP1400-114-(-)(-)					40.0	80.0
EP1400-115-(-)(-)					45.0	88.0
EP1400-116-(-)(-)	2, 5	1	3/8	1/2	9.0	20.0
EP1400-117-(-)(-)					11.5	30.0
EP1400-118-(-)(-)					15.5	35.0
EP1400-119-(-)(-)					18.0	41.0
EP1400-120-(-)(-)					20.5	45.0

Cylindrical Mount Series: 5/16-18 Threads

*Ordering example: EP1400-121-(2)-(NR) = 1" dia x 1" long, 37 lbs. load, Style 2, Natural Rubber

PART NUMBER	STYLES AVAILABLE	DIA (in.)	T (in.)	STANDARD STUD LENGTH (in.)	MAXIMUM STATIC LOAD (lbs.)	
					Shear	Compression
EP1400-121-(-)(-)	1, 2, 3, 4, 5	1	1	1/2	15.0	37.0
EP1400-122-(-)(-)					23.0	50.0
EP1400-123-(-)(-)					35.0	62.0
EP1400-124-(-)(-)					43.0	85.0
EP1400-125-(-)(-)					48.0	91.0
EP1400-126-(-)(-)	1, 2, 4, 5	3/4	3/4	1/2	9.5	24.0
EP1400-127-(-)(-)					14.0	32.0
EP1400-128-(-)(-)					18.0	38.0
EP1400-129-(-)(-)					22.0	45.0
EP1400-130-(-)(-)					28.5	50.0
EP1400-131-(-)(-)	1, 2, 4, 5	1	1 1/4	5/8	16.5	40.0
EP1400-132-(-)(-)					25.0	52.0
EP1400-133-(-)(-)					37.0	63.0
EP1400-134-(-)(-)					45.0	87.0
EP1400-135-(-)(-)					50.0	98.0
EP1400-146-(-)(-)	2	3/4	3/8	1/2	N/A	22.0
EP1400-147-(-)(-)					N/A	28.5
EP1400-148-(-)(-)					N/A	35.0
EP1400-149-(-)(-)					N/A	41.0
EP1400-150-(-)(-)					N/A	48.5

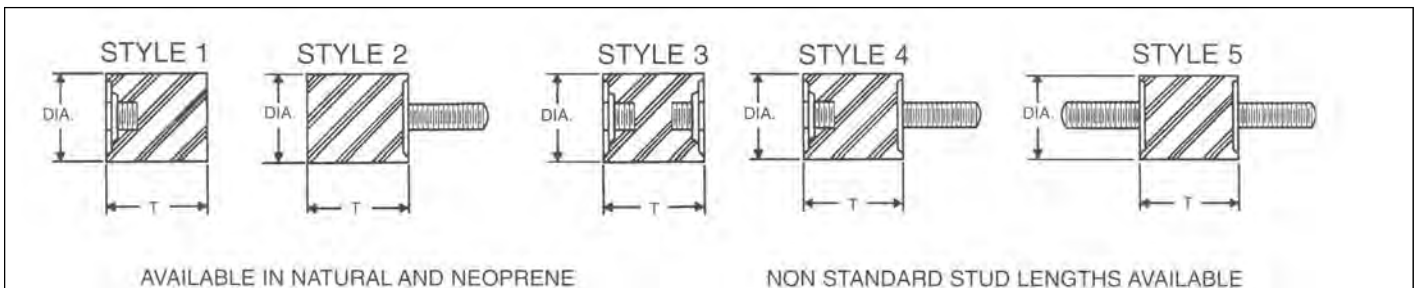

Cylindrical Mount Series: 5/16-18 Threads

*Ordering example: EP1400-156-(2)-(N) = 1 1/4 dia x 3/4 long, 55 lbs. load, Style 2, Neoprene

PART NUMBER	STYLES AVAILABLE	DIA (in.)	T (in.)	STANDARD STUD LENGTH (in.)	MAXIMUM STATIC LOAD (lbs.)	
					Shear	Compression
EP1400-156-(-)(-)	1, 2, 4, 5	1 1/4	3/4	9/16	30.0	55.0
EP1400-157-(-)(-)					40.0	75.0
EP1400-158-(-)(-)					50.0	100
EP1400-159-(-)(-)					60.0	140
EP1400-160-(-)(-)					70.0	155
EP1400-161-(-)(-)	1, 2, 3, 4, 5	1 1/4	1	9/16	30.0	55.0
EP1400-162-(-)(-)					40.0	80.0
EP1400-163-(-)(-)					49.0	112
EP1400-164-(-)(-)					60.0	126
EP1400-165-(-)(-)					69.0	140
EP1400-166-(-)(-)	1, 2, 3, 4, 5	1 1/4	7/8	9/16	32.0	56.0
EP1400-167-(-)(-)					37.0	82.0
EP1400-168-(-)(-)					48.0	115
EP1400-169-(-)(-)					63.0	123
EP1400-170-(-)(-)					75.0	135
EP1400-171-(-)(-)	1, 2, 3, 4, 5	1 1/4	1 1/4	9/16	21.0	41.0
EP1400-172-(-)(-)					31.0	64.0
EP1400-173-(-)(-)					48.0	90.0
EP1400-174-(-)(-)					63.0	120
EP1400-175-(-)(-)					72.0	140
EP1400-176-(-)(-)	2	1 1/4	1/4	9/16	N/A	75.0
EP1400-177-(-)(-)					N/A	100
EP1400-178-(-)(-)					N/A	132
EP1400-179-(-)(-)					N/A	146
EP1400-180-(-)(-)					N/A	160
EP1400-181-(-)(-)	2, 4, 5	1 3/8	5/8	9/16	36.0	93.0
EP1400-182-(-)(-)					46.0	118
EP1400-183-(-)(-)					57.0	158
EP1400-184-(-)(-)					67.0	185
EP1400-185-(-)(-)					77.0	220

E

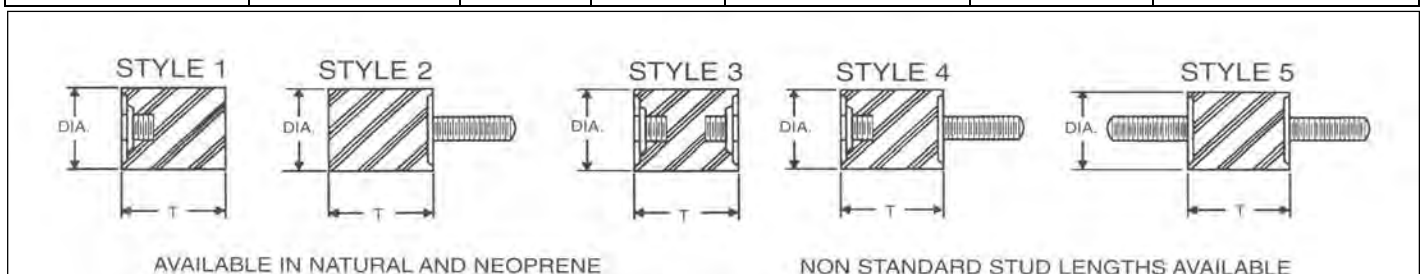

Cylindrical Mount Series: 5/16-18 Threads

*Ordering example: EP1400-191-(5)-(N) = 1 3/8 dia x 1" long, 55 lbs. load, Style 5, Neoprene

PART NUMBER	STYLES AVAILABLE	DIA (in.)	T (in.)	STANDARD STUD LENGTH (in.)	MAXIMUM STATIC LOAD (lbs.)	
					Shear	Compression
EP1400-191-(-)(-)	1, 2, 4, 5	1 3/8	1	9/16	30.0	55.0
EP1400-192-(-)(-)					40.0	81.0
EP1400-193-(-)(-)					50.0	110
EP1400-194-(-)(-)					61.0	125
EP1400-195-(-)(-)					70.0	142
EP1400-201-(-)(-)	2, 4, 5	1 3/8	1 1/2	9/16	30.0	90.0
EP1400-202-(-)(-)					42.0	110
EP1400-203-(-)(-)					53.0	148
EP1400-204-(-)(-)					62.0	179
EP1400-205-(-)(-)					70.0	195
EP1400-206-(-)(-)	2, 4, 5	1 1/2	3/4	9/16	23.5	44.5
EP1400-207-(-)(-)					35.0	67.0
EP1400-208-(-)(-)					49.5	102
EP1400-209-(-)(-)					63.5	115
EP1400-210-(-)(-)					72.0	125
EP1400-211-(-)(-)	2, 4, 5	1 1/2	1	9/16	22.0	43.0
EP1400-212-(-)(-)					33.0	65.0
EP1400-213-(-)(-)					48.0	100
EP1400-214-(-)(-)					62.0	110
EP1400-215-(-)(-)					70.0	119
EP1400-216-(-)(-)	2, 4, 5	1 1/2	1.2	9/16	20.0	41.0
EP1400-217-(-)(-)					31.5	63.0
EP1400-218-(-)(-)					46.0	97.5
EP1400-219-(-)(-)					60.0	107
EP1400-220-(-)(-)					67.5	115
EP1400-246-(-)(-)	2, 4, 5	1 1/2	1 1/2	9/16	18.0	39.5
EP1400-247-(-)(-)					24.5	61.0
EP1400-248-(-)(-)					44.5	96.0
EP1400-249-(-)(-)					57.5	105
EP1400-250-(-)(-)					65.0	112

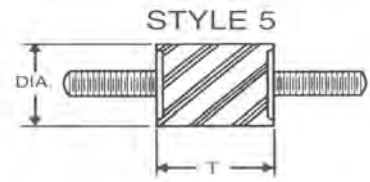
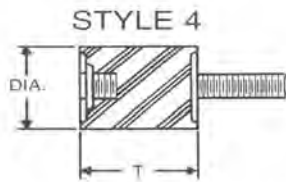
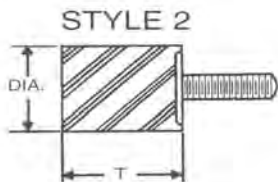

AVAILABLE IN NATURAL AND NEOPRENE

NON STANDARD STUD LENGTHS AVAILABLE

Cylindrical Mount Series: 3/8-16 Threads

*Ordering example: EP1500-106-(5)-(NR) = 1" dia x 1" long, 37 lbs. load, Style 5, Natural Rubber



PART NUMBER	STYLES AVAILABLE	DIA (in.)	T (in.)	STANDARD STUD LENGTH (in.)	MAXIMUM STATIC LOAD (lbs.)	
					Shear	Compression
EP1500-106-(-)(-)	2, 4, 5	1	1	3/8	18.0	37.0
EP1500-107-(-)(-)					25.0	50.0
EP1500-108-(-)(-)					35.0	62.0
EP1500-109-(-)(-)					43.0	85.0
EP1500-110-(-)(-)					48.0	91.0
EP1500-111-(-)(-)	2, 4, 5	1 1/2	1	3/4	22.0	95
EP1500-112-(-)(-)					33.0	135
EP1500-113-(-)(-)					48.0	185
EP1500-114-(-)(-)					62.0	210
EP1500-115-(-)(-)					70.0	210
EP1500-126-(-)(-)	2, 4, 5	2	3/4	3/4	45	250
EP1500-127-(-)(-)					70	310
EP1500-128-(-)(-)					90	370
EP1500-129-(-)(-)					110	450
EP1500-130-(-)(-)					140	560

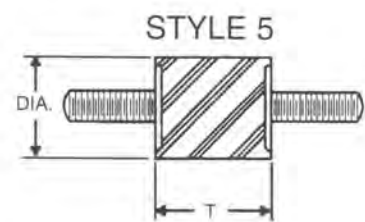
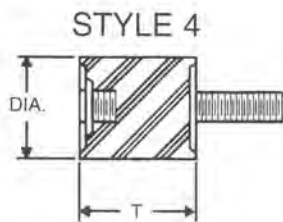
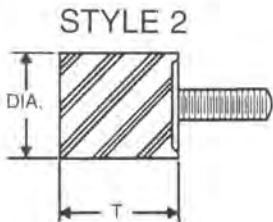

AVAILABLE IN NATURAL AND NEOPRENE

Cylindrical Mount Series: 3/8-16 Threads

*Ordering example: EP1500-131-(5)-(N) = 2" dia x 1 1/2 long, 80 lbs. load, Style 5, Neoprene

PART NUMBER	STYLES AVAILABLE	DIA (in.)	T (in.)	STANDARD STUD LENGTH (in.)	MAXIMUM STATIC LOAD (lbs.)	
					Shear	Compression
EP1500-131-(-)-(-)	2, 5	2	1 1/2	3/4	35.0	80.0
EP1500-132-(-)-(-)					40.0	100
EP1500-133-(-)-(-)					55.0	165
EP1500-134-(-)-(-)					65.0	240
EP1500-135-(-)-(-)					80.0	350
EP1500-141-(-)-(-)	2, 5	2	1 3/4	3/4	24.0	80.0
EP1500-142-(-)-(-)					29.0	135
EP1500-143-(-)-(-)					58.0	280
EP1500-144-(-)-(-)					79.0	360
EP1500-145-(-)-(-)					29.0	8.5
EP1500-151-(-)-(-)	2, 5	2	2 1/8	3/4	32.0	140
EP1500-152-(-)-(-)					44.0	250
EP1500-153-(-)-(-)					50.0	110
EP1500-154-(-)-(-)					58.0	285
EP1500-155-(-)-(-)					92.0	380

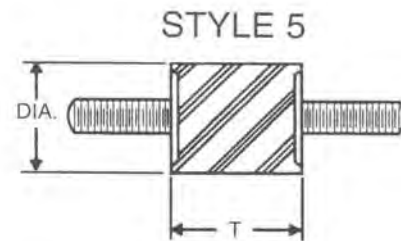
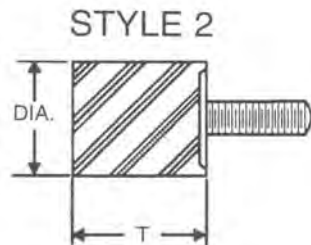

AVAILABLE IN NATURAL AND NEOPRENE

Conical Mount Series: 5/16-18 Threads

*Ordering example: EP1600-101-(NR) = 1 1/4 long, 90 lbs. load, Natural Rubber

E

PART NUMBER	D ₁ (in.)	D ₂ (in.)	T (in.)	S (in.)	STATIC LOAD (lbs.)	DYNAMIC LOAD (lbs.)
EP1600-101(-)	1 1/2	1	1 1/4	9/16	44	90
EP1600-102(-)					49	100
EP1600-103(-)					56	125
EP1600-104(-)					62	150
EP1600-105(-)					68	160
EP1600-106(-)	1 1/2	1	1 1/4	5/8	44	90
EP1600-107(-)					49	100
EP1600-108(-)					56	125
EP1600-109(-)					62	150
EP1600-110(-)					68	160
EP1600-111(-)	1 1/2	1	1 1/4	3/4	44	90
EP1600-112(-)					49	100
EP1600-113(-)					56	125
EP1600-114(-)					62	150
EP1600-115(-)					68	160
EP1600-121(-)	1 1/2	1	1 1/4	1 1/8	44	90
EP1600-122(-)					49	100
EP1600-123(-)					56	125
EP1600-124(-)					62	150
EP1600-125(-)					68	160
EP1600-126(-)	1 1/2	1	1 1/4	1	44	90
EP1600-127(-)					49	100
EP1600-128(-)					56	125
EP1600-129(-)					62	150
EP1600-130(-)					68	160
EP1600-131(-)	1 1/2	1	1 1/4	1 1/2	44	90
EP1600-132(-)					49	100
EP1600-133(-)					56	125
EP1600-134(-)					62	150
EP1600-135(-)					68	160

Conical Mount Series: 5/16-18 Threads

*Ordering example: EP1600-141-(N) = 1 1/4 long, 90 lbs. load, Neoprene

PART NUMBER	D ₁ (in.)	D ₂ (in.)	T (in.)	S (in.)	STATIC LOAD (lbs.)	DYNAMIC LOAD (lbs.)
EP1600-141-(-)	1 1/2	1	1 1/4	1/2	44	90
EP1600-142-(-)					49	100
EP1600-143-(-)					56	125
EP1600-144-(-)					62	150
EP1600-145-(-)					68	160
EP1600-301-(-)	1 5/8	1 3/8	1	5/8	40	85
EP1600-302-(-)					55	115
EP1600-303-(-)					80	175
EP1600-304-(-)					100	205
EP1600-305-(-)					180	350

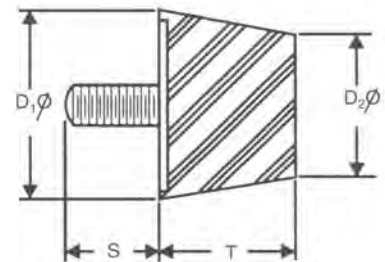

AVAILABLE IN NATURAL AND NEOPRENE

Cylindrical Mount Series

*Ordering example: EP1700-101-(N) = 1 1/32 long, 260 lbs. load, Neoprene

E

PART NUMBER	D ₁ (in.)	D ₂ (in.)	T (in.)	THREAD	S (in.)	STATIC LOAD (lbs.)	DYNAMIC LOAD (lbs.)
EP1700-101(-)	2 3/4	2	1 1/32	1/2-13	1 1/4	110	260
EP1700-102(-)						140	330
EP1700-103(-)						165	380
EP1700-104(-)						190	430
EP1700-105(-)						230	500
EP1700-111(-)	2 3/4	2	1 1/32	1/2-20	29/32	110	260
EP1700-112(-)						140	330
EP1700-113(-)						165	380
EP1700-114(-)						190	430
EP1700-115(-)						230	500

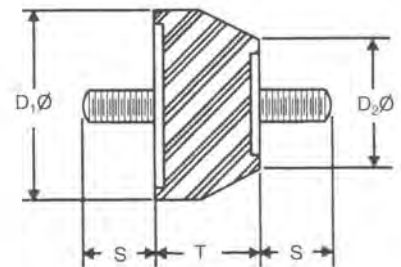

AVAILABLE IN NATURAL AND NEOPRENE

Cylindrical Mount Series

*Ordering example: EP1830-301-(3)-(N) = 2" dia x 1 3/4 long, 40 lbs. load, Style 3, Neoprene

PART NUMBER	STYLE	DIA. (in.)	T (in.)	THREAD	COMPRESSION (lbs.)	SHEAR (lbs.)
EP1830-301-(-)-(-)	3	2	1 3/4	1/2-13	90	40
EP1830-302-(-)-(-)					120	60
EP1830-303-(-)-(-)					160	80
EP1830-304-(-)-(-)					225	100
EP1830-305-(-)-(-)					480	200
EP1830-311-(-)-(-)	3	2	2 1/8	1/2-13	80	30
EP1830-312-(-)-(-)					100	40
EP1830-313-(-)-(-)					135	55
EP1830-314-(-)-(-)					180	70
EP1830-315-(-)-(-)					400	140
EP1810-331-(-)-(-)	1	2	1 3/4	1/2-13	90	N/A
EP1810-332-(-)-(-)					150	N/A
EP1810-333-(-)-(-)					275	N/A
EP1810-334-(-)-(-)					625	N/A
EP1810-335-(-)-(-)					780	N/A
EP1810-341-(-)-(-)	1	2	1	1/2-13	95	N/A
EP1810-342-(-)-(-)					160	N/A
EP1810-343-(-)-(-)					300	N/A
EP1810-344-(-)-(-)					650	N/A
EP1810-345-(-)-(-)					725	N/A
EP1810-361-(-)-(-)	3	2	2 5/8	1/2-13	60	15
EP1810-362-(-)-(-)					90	30
EP1810-363-(-)-(-)					125	45
EP1810-364-(-)-(-)					160	50
EP1810-365-(-)-(-)					385	100

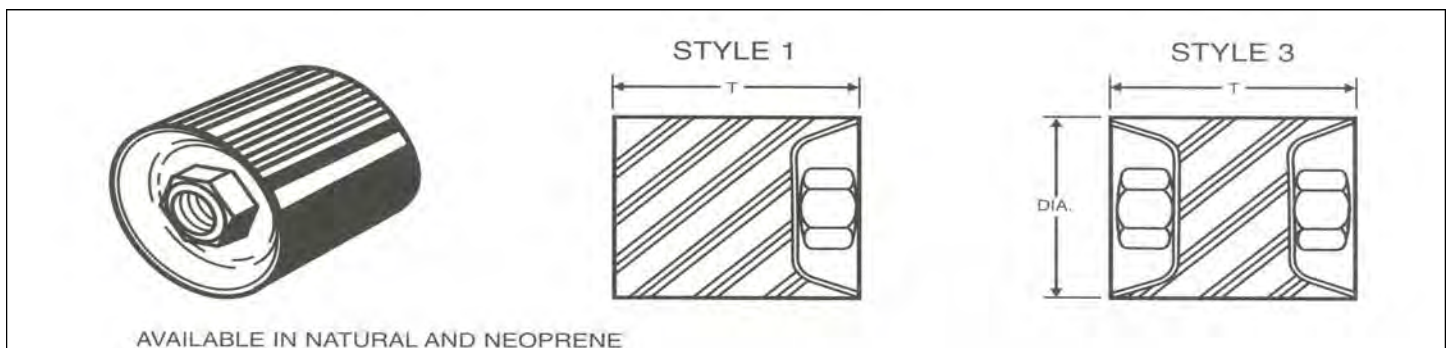

DAMPING MATERIALS

Available in sheets, die-cut or water-jet shapes.

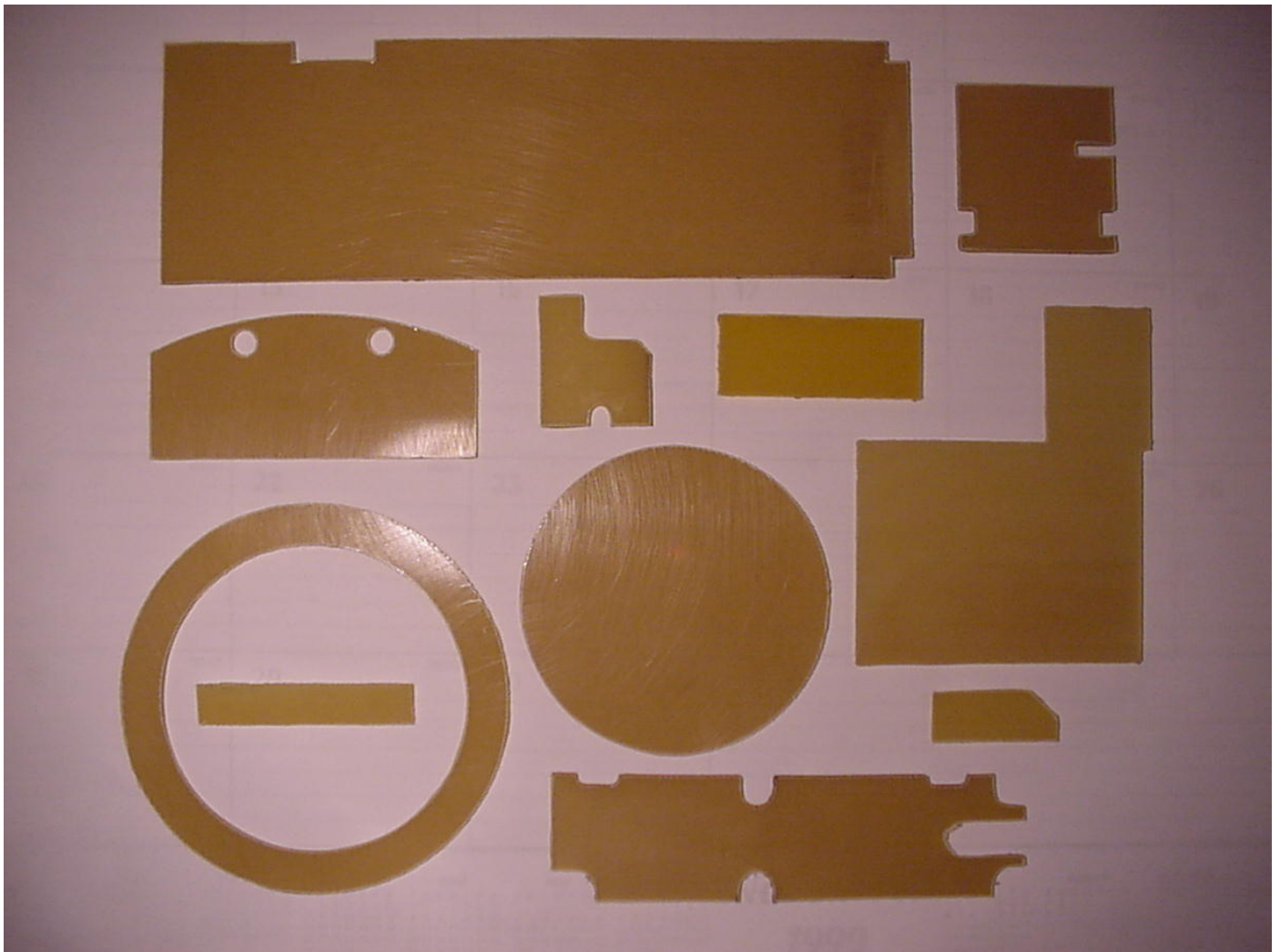

Constrained Layer Damping Material

Reduction of vibration in circuit boards and panel-type structures using a highly damped, constrained viscoelastic material

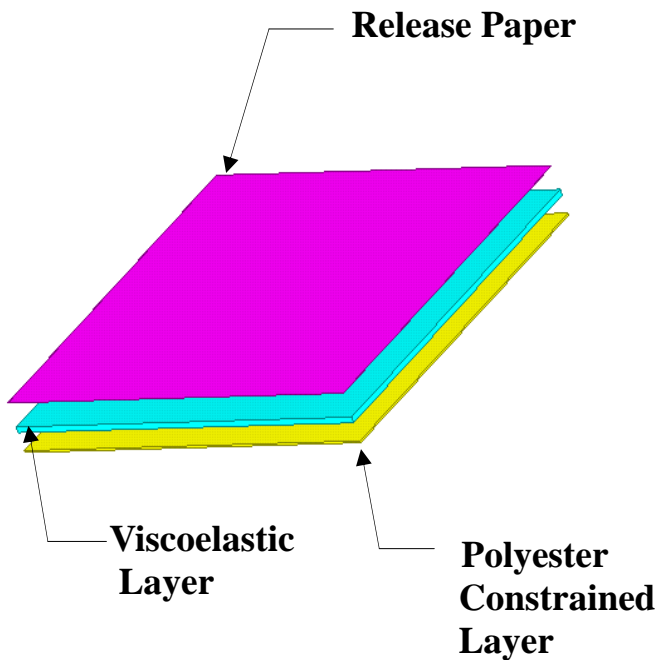

Attributes

The CLDM material effectively and efficiently reduces the amount of vibration transmitted to a structure resulting in longer fatigue life of the structure or circuit board components. Typically, undamped structures have resonant transmissibility's of 30:1 to 50:1 compared to the input. Damped systems have transmissibility's of 3:1 to 10:1. This significant decrease in transmissibility directly correlates to a reduction in sound power transmission from the structure at resonance. Circuit boards can be ruggedized efficiently and cost effectively without changes to the components of the circuit board.

Applications

The CLDM damping material has three layers: a viscoelastic damping material, a polyester constraining layer, and a protective release paper. The CLDM material is designed to offer the maximum amount of structural damping to circuit boards and panel structures by shearing the highly damped viscoelastic layer.

Material Properties

Temperature range----- -60F to 200F
Thermal Conductivity----- 1.712 BTU-IN/HR/FT²/F
Tensile Strength----- 52 PSI
Adhesive Peel Strength---- 122 OZ/IN after 5 MIN
 156 OZ/IN after 24 HR
Breakdown Voltage----- 45 KVAC
Specific Gravity ----- 1.234 Grams/CM³
Dielectric Strength----- 490 Volts/MM
Shear Strength----- 45PSI
Fungus Resistance----- No Growth
Shelf Life----One Year from Date of Manufacture

Installation Data

To install the CLDM material, simply remove the protective release paper and place the damping material on the undamped structure. In circuit board application, the CLDM material must cover at least 60% of the back of the circuit board. Hand pressure is all that is required to adhere the CLDM damper. No additional pressure or curing is needed. The CLDM material is flexible enough to adhere to slightly imperfect surfaces.

Dimensions

The CLDM material is available in sheets of different sizes and shapes as well as different constraining layer materials polyester, stainless steel, aluminum, galvanized steel as well other unique materials. The thickness of the constraining and viscoelastic layers can be varied depending on the application's requirements. The data below is based on a .020 inch thick polyester layer and a .060 inch thick viscoelastic layer. We have found that this configuration provides optimal damping of circuit boards and undamped structures.

Input

A Sine sweep of 2G's at 30 to 500 HZ

Constrained Layer Damping Material

VIBRATION CHARACTERISTICS

RANDOM INPUT _____ INCREASED STIFFNESS _____ 27%
 DECREASE IN TRANSMISSIBILITY _____ 59%

SINUSOIDAL INPUT _____ INCREASED STIFFNESS _____ 11%
 DECREASE IN TRANSMISSIBILITY _____ 60%

OUTGASSING CHARACTERISTICS

MATERIAL OUTGASSING _____ TOTAL MASS LOSS _____ 3.23%
 CVCM _____ .52%

FLAMMABILITY CHARACTERISTICS

FLAMMABILITY RESISTANCE _____ FAR 25.853 B-2, B-3

F

TYPICAL CLDM TRANSMISSIBILITY DATA

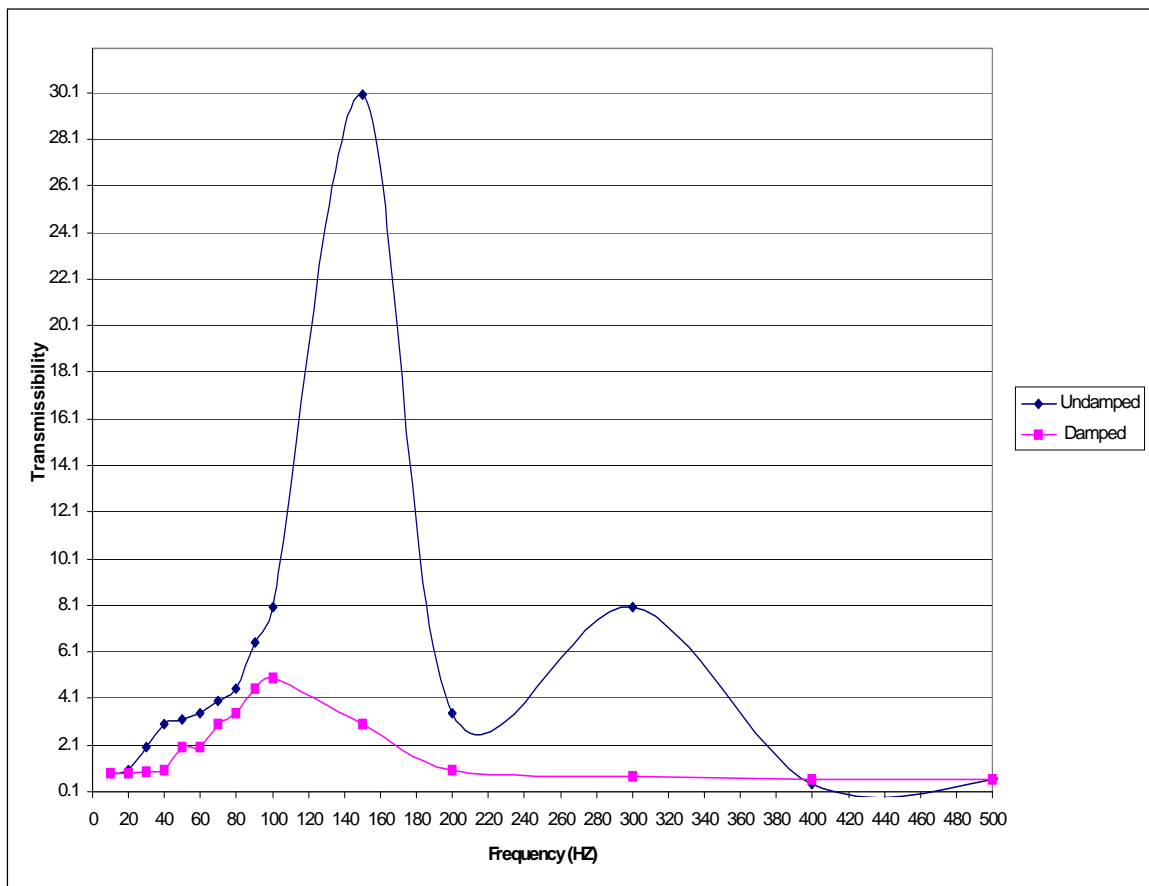

Damping Material 7361D

Reduction of vibration in panel-type structures using a highly damped, constrained viscoelastic material



Attributes

The 7361D material effectively and efficiently reduces the amount of vibration transmitted to a structure resulting in longer fatigue life of the structure or components. Typically, un-damped structures have resonant transmissibility's of 30:1 to 50:1 compared to the input. Damped systems have transmissibility's of 3:1 to 10:1. This significant decrease in transmissibility directly correlates to a reduction in sound power transmission from the structure at resonance. 7361D has an aggressive surface tack and high tensile strength that provides an immediate bond while remaining flexible.

Applications

The 7361D damping material is produced as constrained layer or non constrained layer depending on the application. The constrained version is a viscoelastic damping material, a constraining layer, and a protective release paper. The 7361D material is designed to offer the maximum amount of structural damping to panel structures by shearing the highly damped viscoelastic layer between the two constrained layers.

Material Properties

Hardness (Shore 00)	60-80
Color	Black
Temperature range	25F to 180F
Thermal Conductivity	1.972 BTU-IN/HR/FT ² /F
Breakdown Voltage	60 KVAC
Specific Gravity (ASTM D792)	1.40 Grams/CM ³
Dielectric Strength	490 Volts/MM
Tensile Strength (ASTM C907)	10-18 PSI
Elongation at Break (ASTM C908)	300%
Lap Shear Strength (ASTM C961)	6 PLI Min
Adhesive Peel Strength	49 OZ/IN after 5 73 OZ/IN after 24 HR
Fungus Resistance	No Growth

Installation Data

To install the 7361D material, simply remove the protective release paper and place the damping material on the un-damped structure. The 7361D material must cover at least 80% of the back of the structure. Hand pressure is all that is required to adhere the 7361D damper. No additional pressure or curing is needed. The 7361D material is flexible enough to adhere to imperfect surfaces no primer is required.

Dimensions

The 7361D material is available in sheets of different sizes and shapes as well as different constraining layer materials polyester, stainless steel, aluminum, galvanized steel as well other unique materials . The thickness of the constraining and viscoelastic layers can be varied depending on the application's requirements. The data below is based on a .005 inch thick aluminum layer and a .039 inch thick viscoelastic layer. We have found that this configuration provides optimal damping of un-damped structures.

Damping Material 7361D

Composite Loss Factor of 7361D at 30, 60 and 71 C from Oberst Bar Damping Tests

Sample Description: .005 aluminum with 1 MM 7361D

Measured Sample Thickness 1.3 MM

Measured Sample Surface Weight 1.7 kg/m²

Steel Bar- Free length 200 mm, Thickness 0.8 mm, Width 12.7 mm

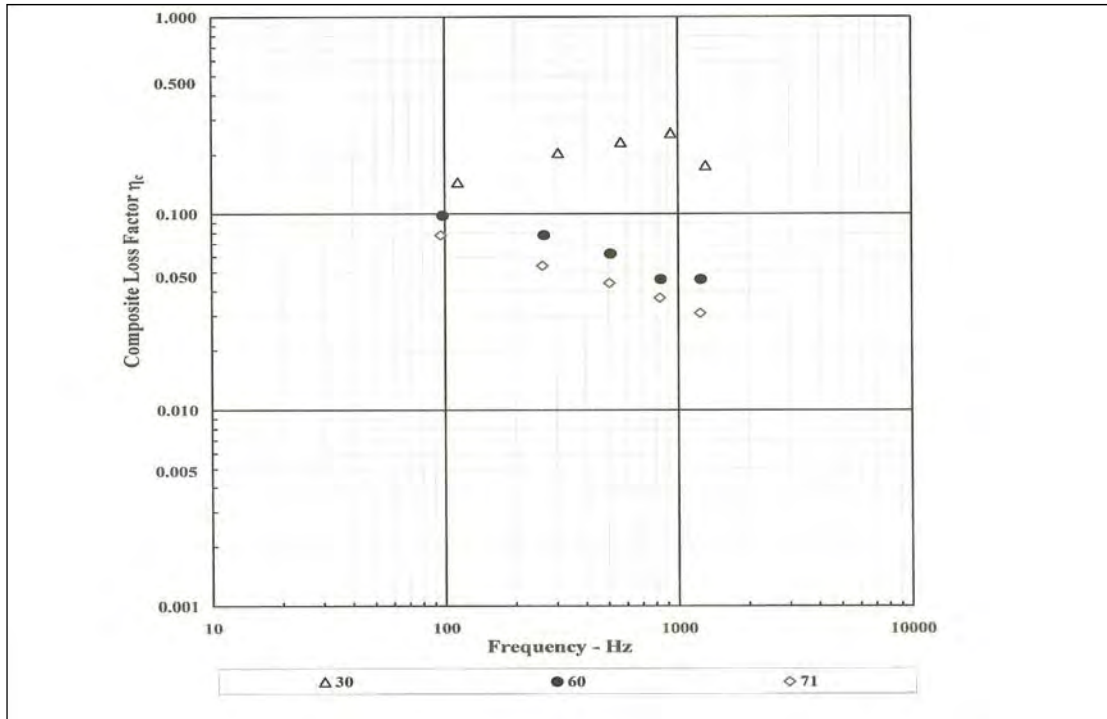

F

Dynamic Mechanical Thermal Analysis Test

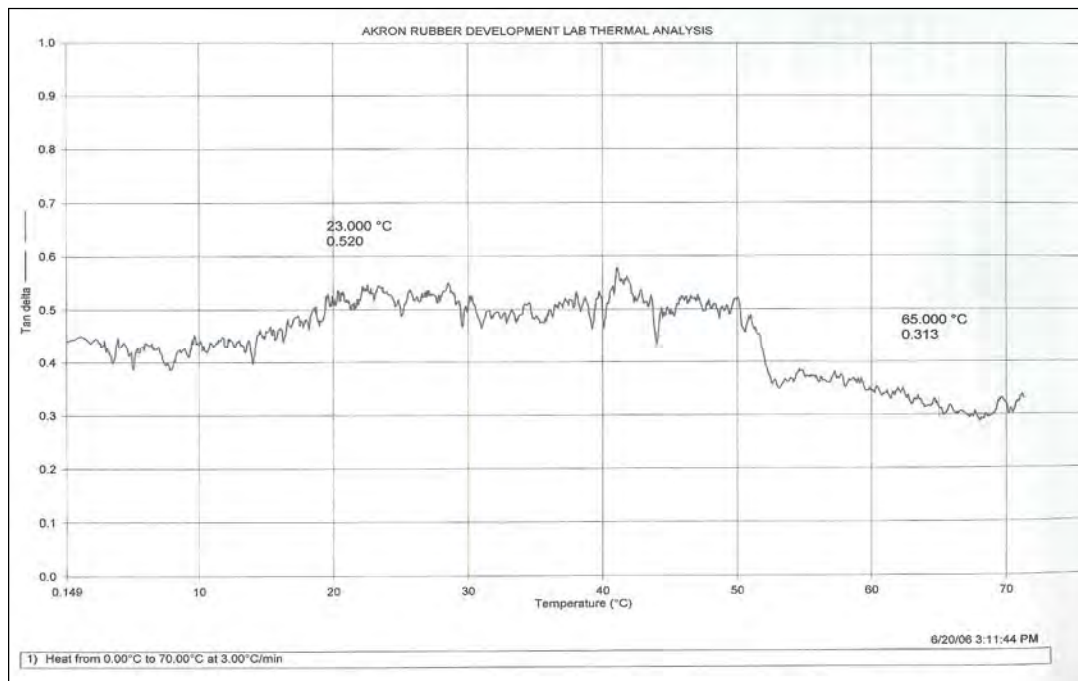

DOMESTIC MOUNT SERIES



Dome Mount Series

Low profile, fail-safe, easy to install for vibration and shock accommodation



Applications

- Industrial machinery
- Military/defense
- Power generation
- HVAC
- Large motors/pumps/ compressors
- Diesel engine applications

G

Attributes

- Fail-safe design
- Wide load range covered by four sizes
- Low height for tight locations
- One piece mount
- Threaded core
- Top-down assembly

Load Range

- 1961-1 = load ratings to 325 lbs.
- 1961-2 = load ratings to 800 lbs.
- 1961-3 = load ratings to 925 lbs.
- 1961-4 = load ratings to 1425 lbs.

Specifications

- Natural frequency—8-15 Hertz
- Transmissibility at resonance - 10:1
- Resilient Element—Neoprene and Natural Rubber
- Standard materials—Zinc phosphate, low carbon steel

Elastomeric Data

- Neoprene elastomer has an operating temperature range of -40°F to 200°F (-40°C to $+93^{\circ}\text{C}$) and is resistant to oils, most solvents and ozone
- Natural Rubber has an operating temperature range of -25°F to $+160^{\circ}\text{F}$ (-37°C to $+70^{\circ}\text{C}$)
- Other materials are available on special order to meet specific operating characteristics

Dome Mount Series

Dimensions and Load Deflection Curves

PART NUMBER	MAX LOAD (lbs.)	SPRING RATE (lbs./in.)	Color Code
1961-1	375	3,000	Red
1961-2	800	6,400	Orange
1961-3	925	7,400	Yellow
1961-4	1,425	11,500	Green

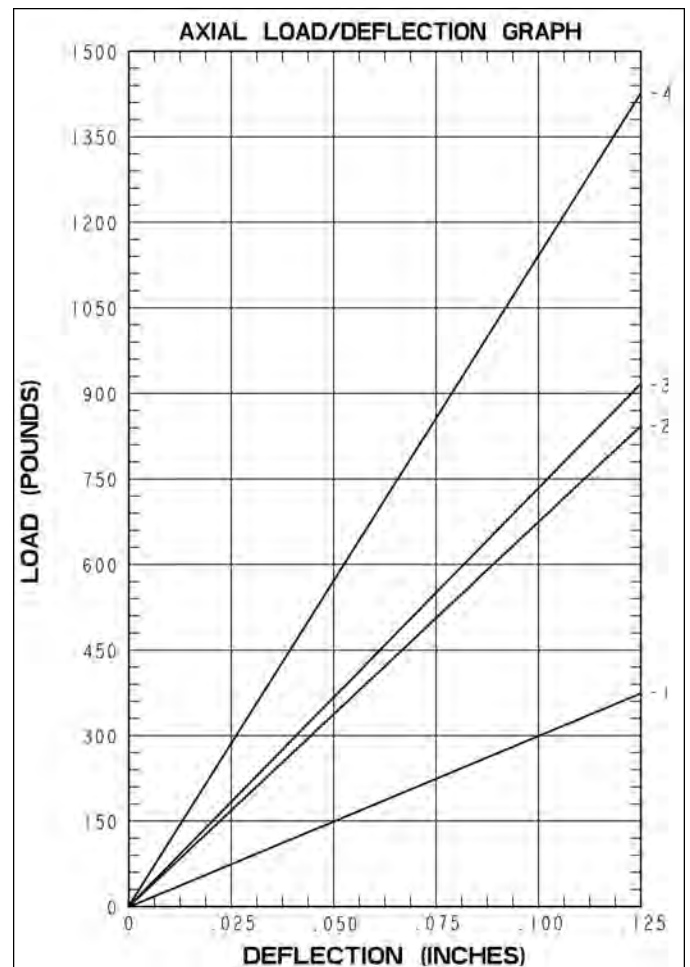
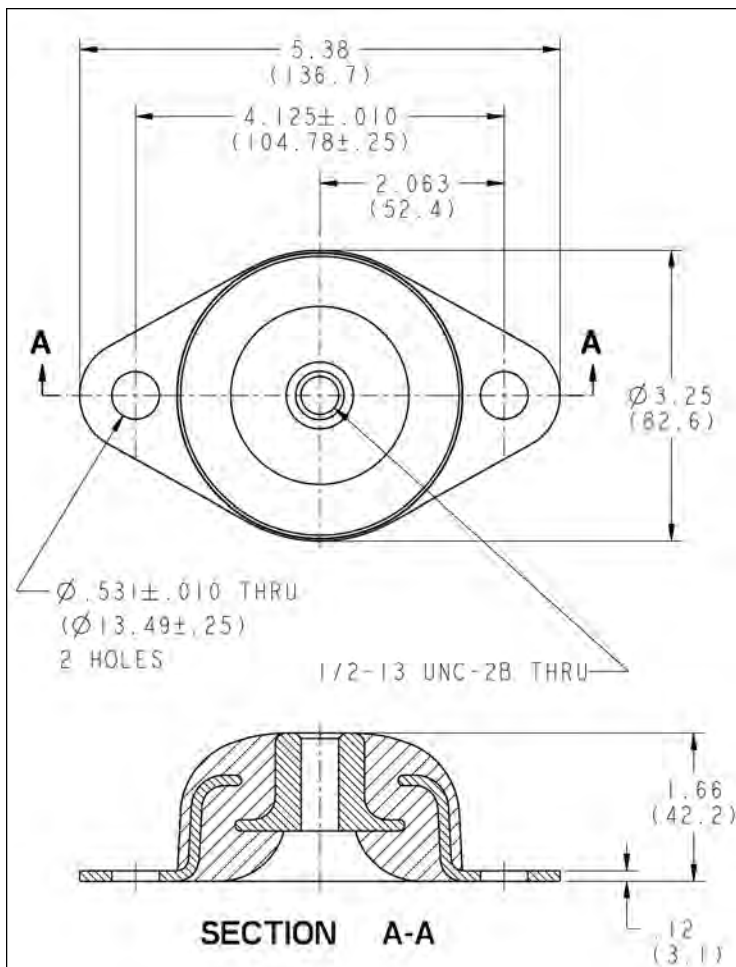

FAIL-SAFE COMPRESSION MOUNT SERIES

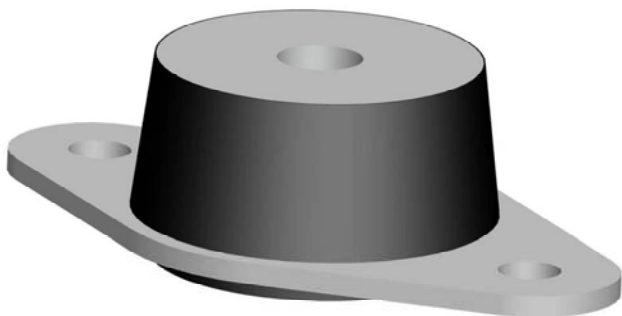
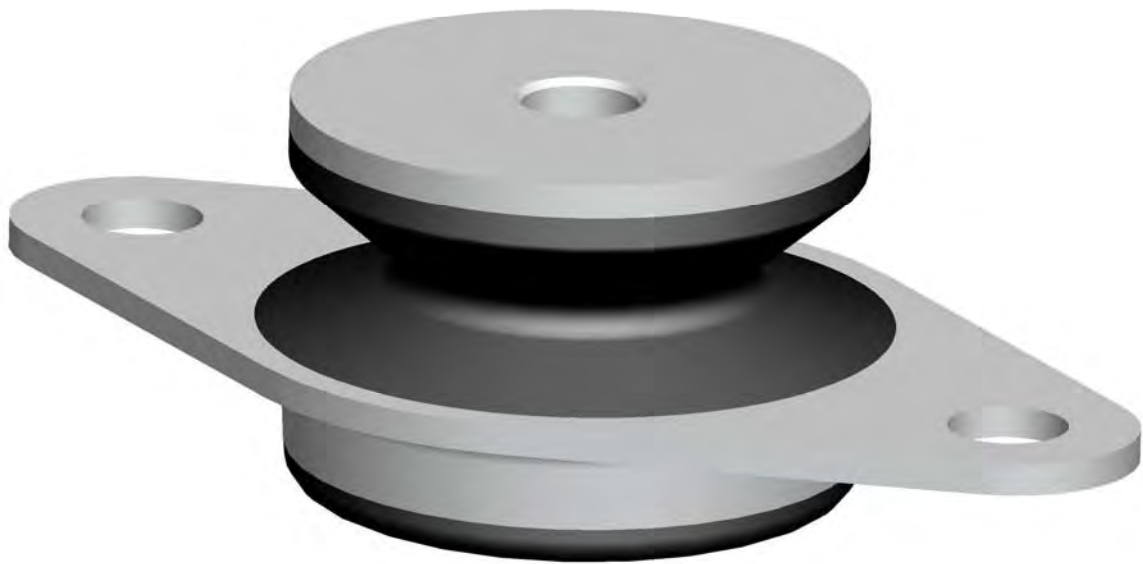

Fail-Safe Compression Mount Series

1751—1757

Compact, high load capacity mounts for vibration and shock protection



Applications

- Lab equipment
- Business machines
- Vehicle application
- Marine engines
- Power generation
- Cab mounts

Benefits

- Easy to install
- Low cost construction
- Can be mounted in both axial and radial direction

Attributes

- All attitude
- Fail-safe design
- Rugged construction
- High fatigue resistance

Load Range

- 1751 = 3 load ratings to 60 lbs.
- 1752 = 3 load ratings to 100 lbs.
- 1753 = 5 load ratings to 220 lbs.
- 1754 = 5 load ratings to 380 lbs.
- 1755 = 5 load ratings to 680 lbs.
- 1756 = 5 load ratings to 1000 lbs.
- 1757 = 5 load ratings to 1780 lbs.

Specifications

- Natural Frequency - 8-18 Hertz
- Transmissibility at resonance - 10:1
- Resilient Element - Neoprene
- Standard materials - Cold-rolled steel
- Standard Finish - Zinc Phosphate, Black Enamel Paint (BP), Electroless Nickel (EN)
- Weight - See dimensional drawings

Elastomeric Data

- Neoprene elastomer has an operating temperature range of -40°F to 200°F (-40°C to $+93^{\circ}\text{C}$) and is resistant to most solvents, oils and ozone
- Special elastomer and finishes are available for applications in severe environments. Please note that Silicone elastomer is not compatible with nickel plating.

Fail-Safe Compression Mount Series: 1751

Dimension and Performance Characteristics

Part #	Nominal Axial Load (lbs.)	Max. Axial Load (lbs.)	Axial Stiffness at .10" Deflection (lbs./in.)	Transmissibility	Free Height (max. in.)	Resilient Materials	Structural Materials	Finish	Core Style	Center Hole	Flange Hole	Color Code
1751-30	25	38	250	10:1	1.25	Neoprene	Steel	Zinc	Thru Hole	.334	.344	Red
1751-40	40	60	400	10:1	1.25	Neoprene	Steel	Zinc	Thru Hole	.334	.344	Orange
1751-50	60	90	600	10:1	1.25	Neoprene	Steel	Zinc	Thru Hole	.334	.344	Yellow
1751-30BP	25	38	250	10:1	1.25	Neoprene	Steel	Black Paint	Thru Hole	.334	.344	Red
1751-40BP	40	60	400	10:1	1.25	Neoprene	Steel	Black Paint	Thru Hole	.334	.344	Orange
1751-50BP	60	90	600	10:1	1.25	Neoprene	Steel	Black Paint	Thru Hole	.334	.344	Yellow
1751-30EN	25	38	250	10:1	1.25	Neoprene	Steel	Electroless Nickel	Thru Hole	.334	.344	Red
1751-40EN	40	60	400	10:1	1.25	Neoprene	Steel	Electroless Nickel	Thru Hole	.334	.344	Orange
1751-50EN	60	90	600	10:1	1.25	Neoprene	Steel	Electroless Nickel	Thru Hole	.334	.344	Yellow

H

Fail-Safe Compression Mount Series: 1751

Dimension and Performance Characteristics

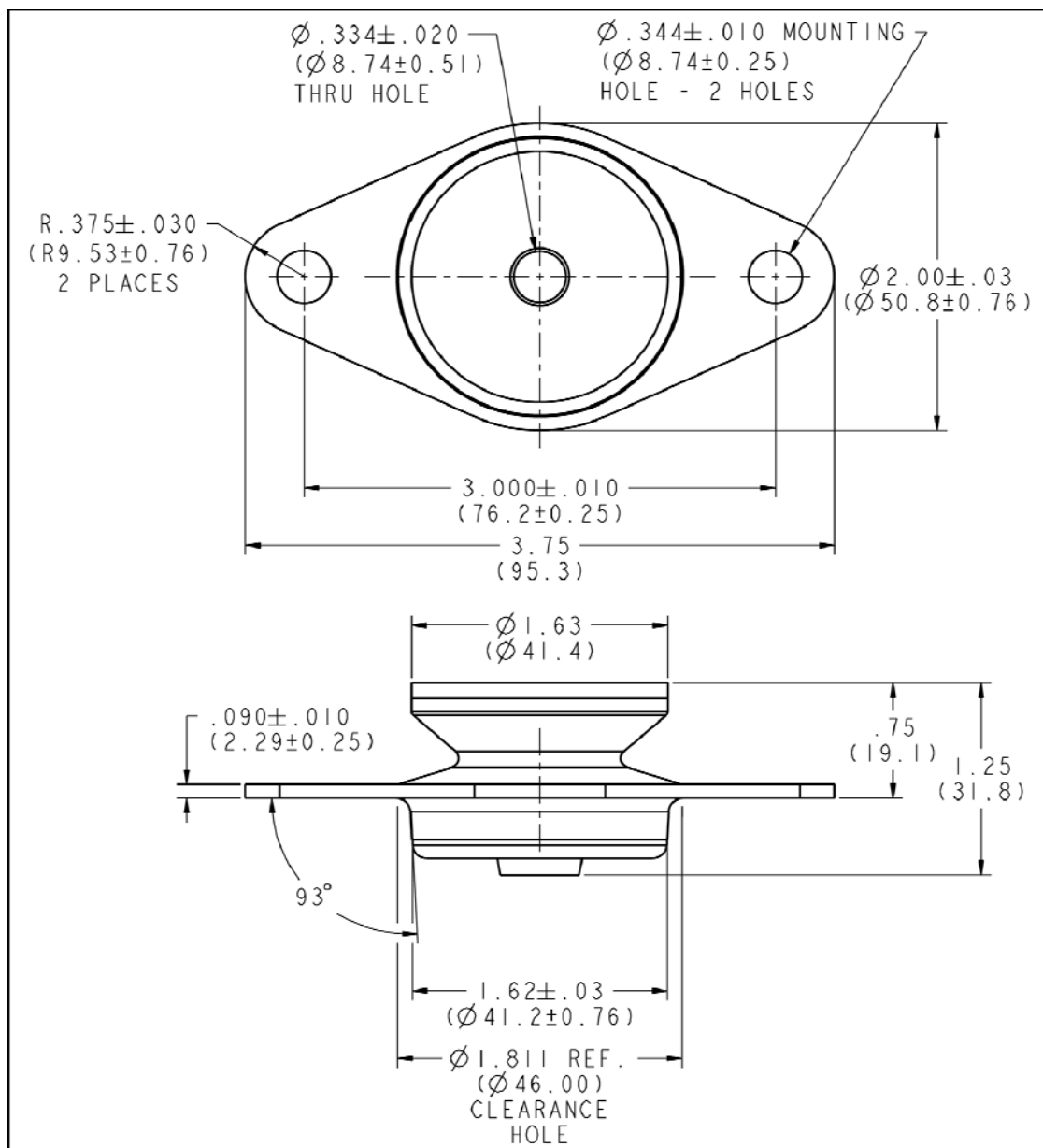

Fail-Safe Compression Mount Series: 1751

Dimension and Performance Characteristics

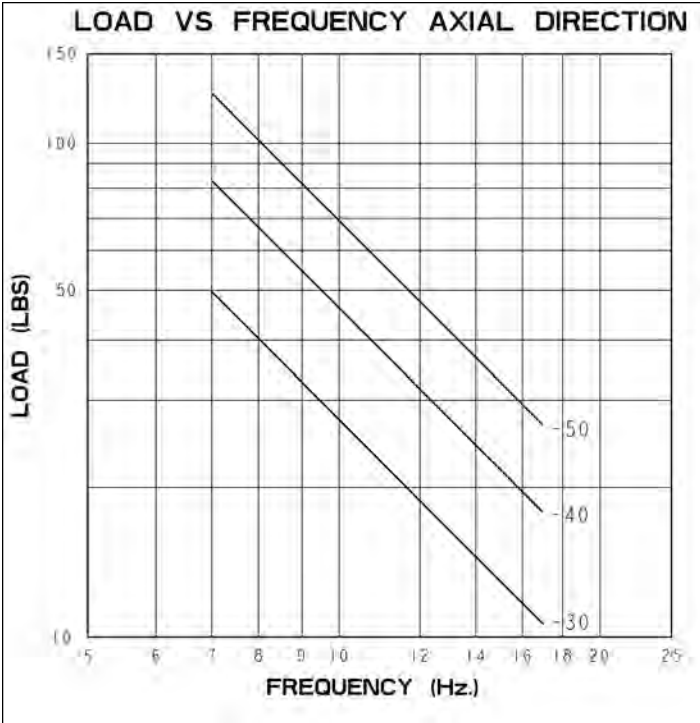

SNUBBING WASHER
P/N SW-1625-0322-0093-SZ
O.D. = Ø 1.630"
I.D. = Ø .322"
THICKNESS = .093"
MATERIAL—1010-1020 CRS
FINISH—CLEAR ZINC

H

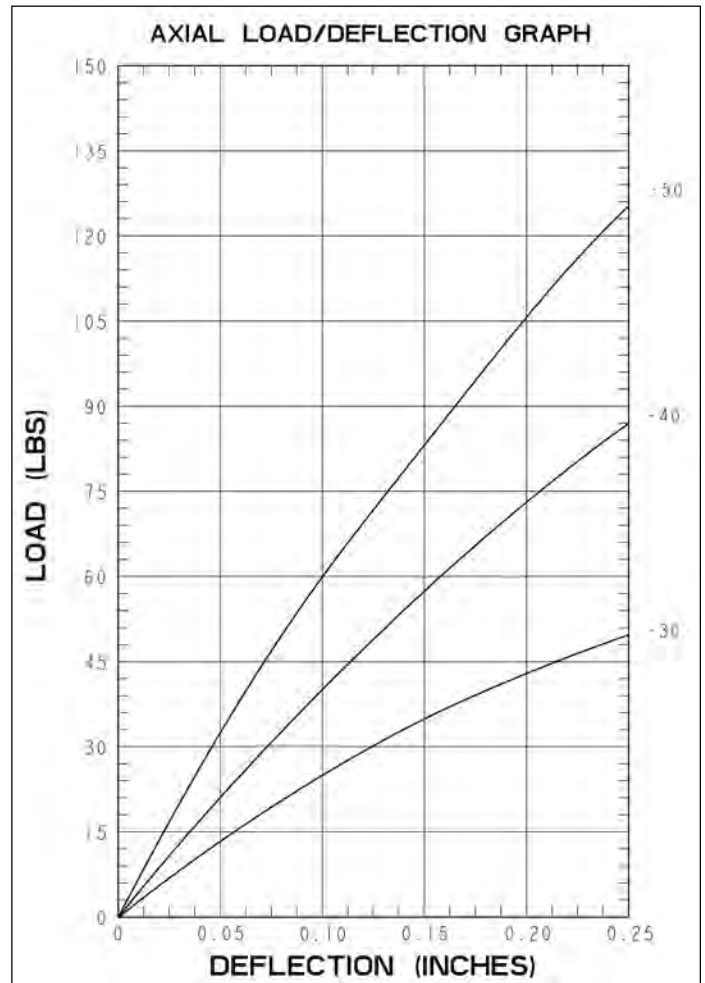

Fail-Safe Compression Mount Series: 1752

Dimension and Performance Characteristics

Part #	Nominal Axial Load (lbs.)	Max. Axial Load (lbs.)	Axial Stiffness at .10" Deflection (lbs./in.)	Transmissibility	Free Height (max. in.)	Resilient Materials	Structural Materials	Finish	Core Style	Center Hole	Flange Hole	Color Code
1752-30	50	75	500	10:1	1.38	Neoprene	Steel	Zinc	Thru Hole	.396	.344	Red
1752-40	70	105	700	10:1	1.38	Neoprene	Steel	Zinc	Thru Hole	.396	.344	Orange
1752-50	100	150	1000	10:1	1.38	Neoprene	Steel	Zinc	Thru Hole	.396	.344	Yellow
1752-30BP	50	75	500	10:1	1.38	Neoprene	Steel	Black Paint	Thru Hole	.396	.344	Red
1752-40BP	70	105	700	10:1	1.38	Neoprene	Steel	Black Paint	Thru Hole	.396	.344	Orange
1752-50BP	100	150	1000	10:1	1.38	Neoprene	Steel	Black Paint	Thru Hole	.396	.344	Yellow
1752-30EN	50	75	500	10:1	1.38	Neoprene	Steel	Electroless Nickel	Thru Hole	.396	.344	Red
1752-40EN	70	105	700	10:1	1.38	Neoprene	Steel	Electroless Nickel	Thru Hole	.396	.344	Orange
1752-50EN	100	150	1000	10:1	1.38	Neoprene	Steel	Electroless Nickel	Thru Hole	.396	.344	Yellow

Fail-Safe Compression Mount Series: 1752

Dimension and Performance Characteristics

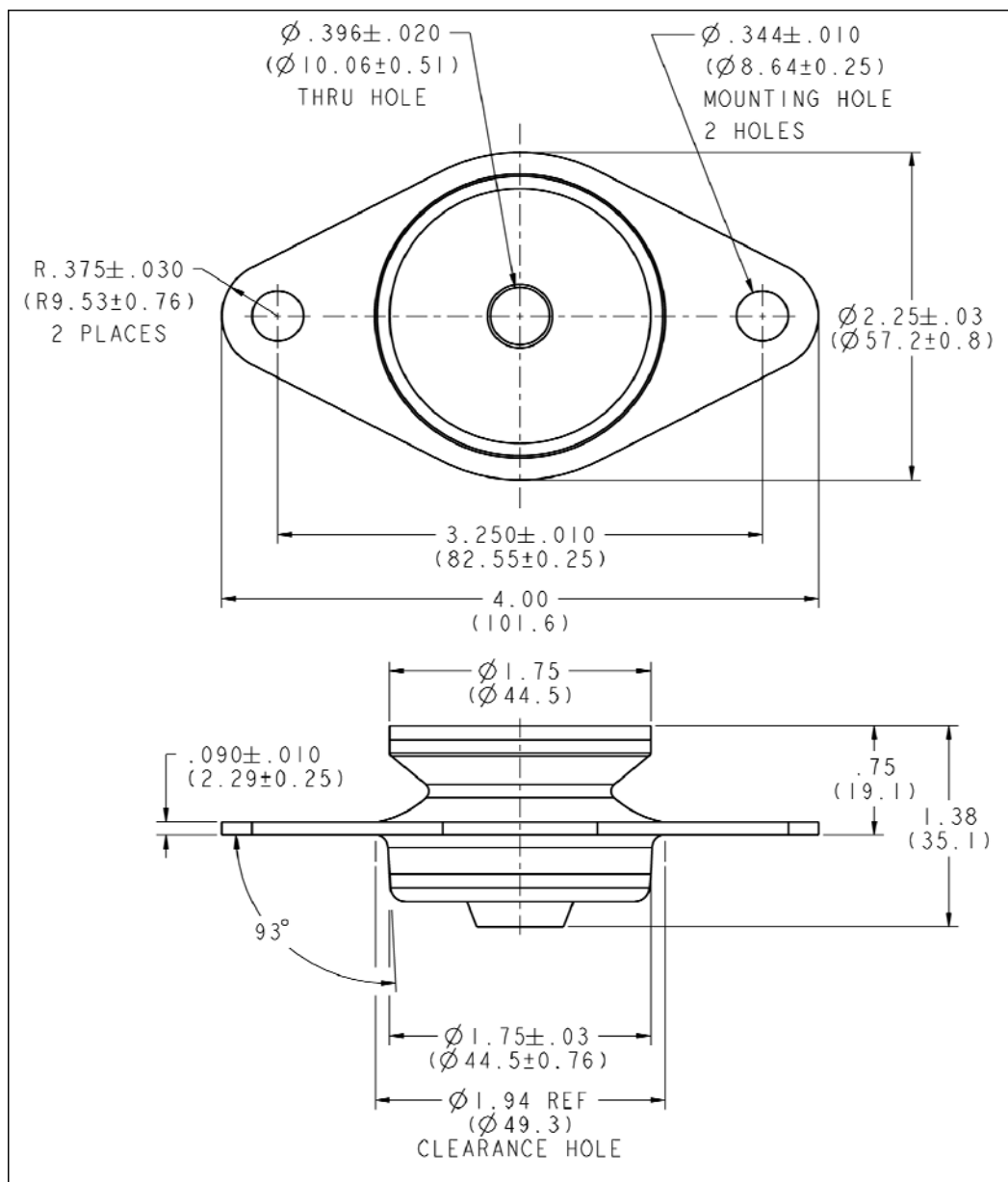

H

Fail-Safe Compression Mount Series: 1752

Dimension and Performance Characteristics

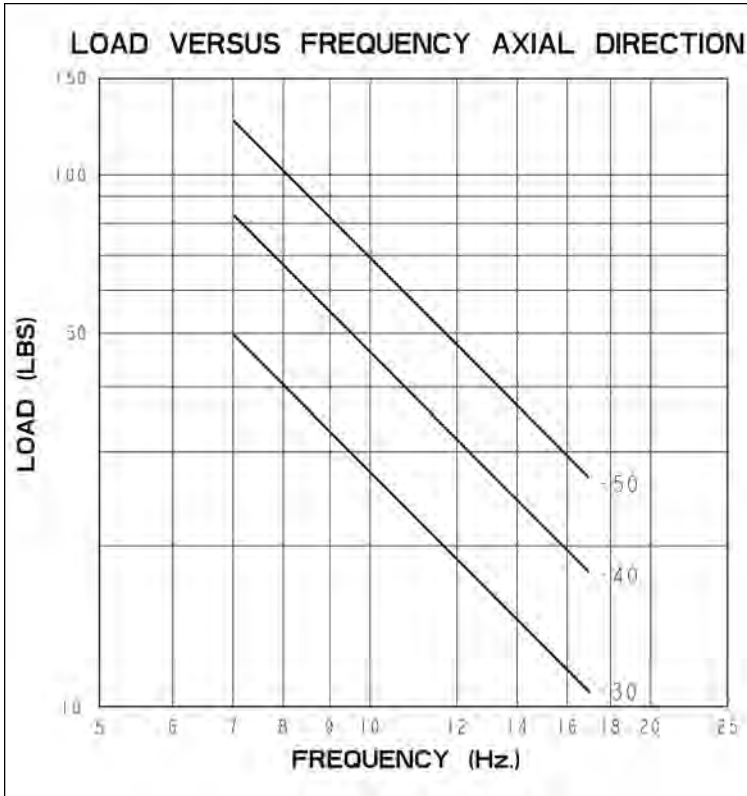

SNUBBING WASHER
P/N SW-1750-0385-0093-SZ
O.D. = \varnothing 1.750"
I.D. = \varnothing .385"
THICKNESS = .093"
MATERIAL—1010-1020 CRS
FINISH—CLEAR ZINC

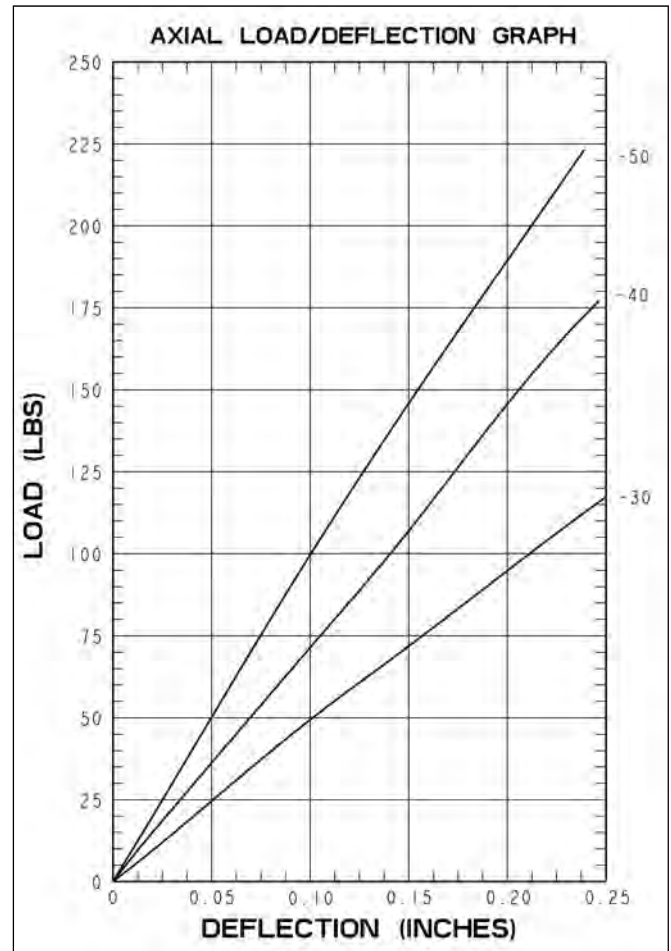

Fail-Safe Compression Mount Series: 1753

Dimension and Performance Characteristics



Part #	Nominal Axial Load (lbs.)	Max. Axial Load (lbs.)	Axial Stiffness at .10" Deflection (lbs./in.)	Radial Static Load Nominal	Radial Static Load Max.	Radial Stiffness at .10" Deflection (lbs./in.)	Transmissibility	Free Height (max. in.)	Resilient Materials	Structural Materials	Finish	Core Style	Center Hole	Flange Hole	Color Code
1753-30	100	150	1000	50	100	500	10:1	1.75	Neoprene	Steel	Zinc	Thru Hole	.459	.406	Red
1753-40	120	180	1200	60	120	600	10:1	1.75	Neoprene	Steel	Zinc	Thru Hole	.459	.406	Orange
1753-50	150	225	1500	75	150	750	10:1	1.75	Neoprene	Steel	Zinc	Thru Hole	.459	.406	Yellow
1753-60	180	270	1800	90	180	900	10:1	1.75	Neoprene	Steel	Zinc	Thru Hole	.459	.406	Green
1753-70	220	330	2200	110	220	1100	10:1	1.75	Neoprene	Steel	Zinc	Thru Hole	.459	.406	Blue
1753-30BP	100	150	1000	50	100	500	10:1	1.75	Neoprene	Steel	Black Paint	Thru Hole	.459	.406	Red
1753-40BP	120	180	1200	60	120	600	10:1	1.75	Neoprene	Steel	Black Paint	Thru Hole	.459	.406	Orange
1753-50BP	150	225	1500	75	150	750	10:1	1.75	Neoprene	Steel	Black Paint	Thru Hole	.459	.406	Yellow
1753-60BP	180	270	1800	90	180	900	10:1	1.75	Neoprene	Steel	Black Paint	Thru Hole	.459	.406	Green
1753-70BP	220	330	2200	110	220	1100	10:1	1.75	Neoprene	Steel	Black Paint	Thru Hole	.459	.406	Blue
1753-30EN	100	150	1000	50	100	500	10:1	1.75	Neoprene	Steel	Electroless Nickel	Thru Hole	.459	.406	Red
1753-40EN	120	180	1200	60	120	600	10:1	1.75	Neoprene	Steel	Electroless Nickel	Thru Hole	.459	.406	Orange
1753-50EN	150	225	1500	75	150	750	10:1	1.75	Neoprene	Steel	Electroless Nickel	Thru Hole	.459	.406	Yellow
1753-60EN	180	270	1800	90	180	900	10:1	1.75	Neoprene	Steel	Electroless Nickel	Thru Hole	.459	.406	Green
1753-70EN	220	330	2200	110	220	1100	10:1	1.75	Neoprene	Steel	Electroless Nickel	Thru Hole	.459	.406	Blue

Fail-Safe Compression Mount Series: 1753

Dimension and Performance Characteristics

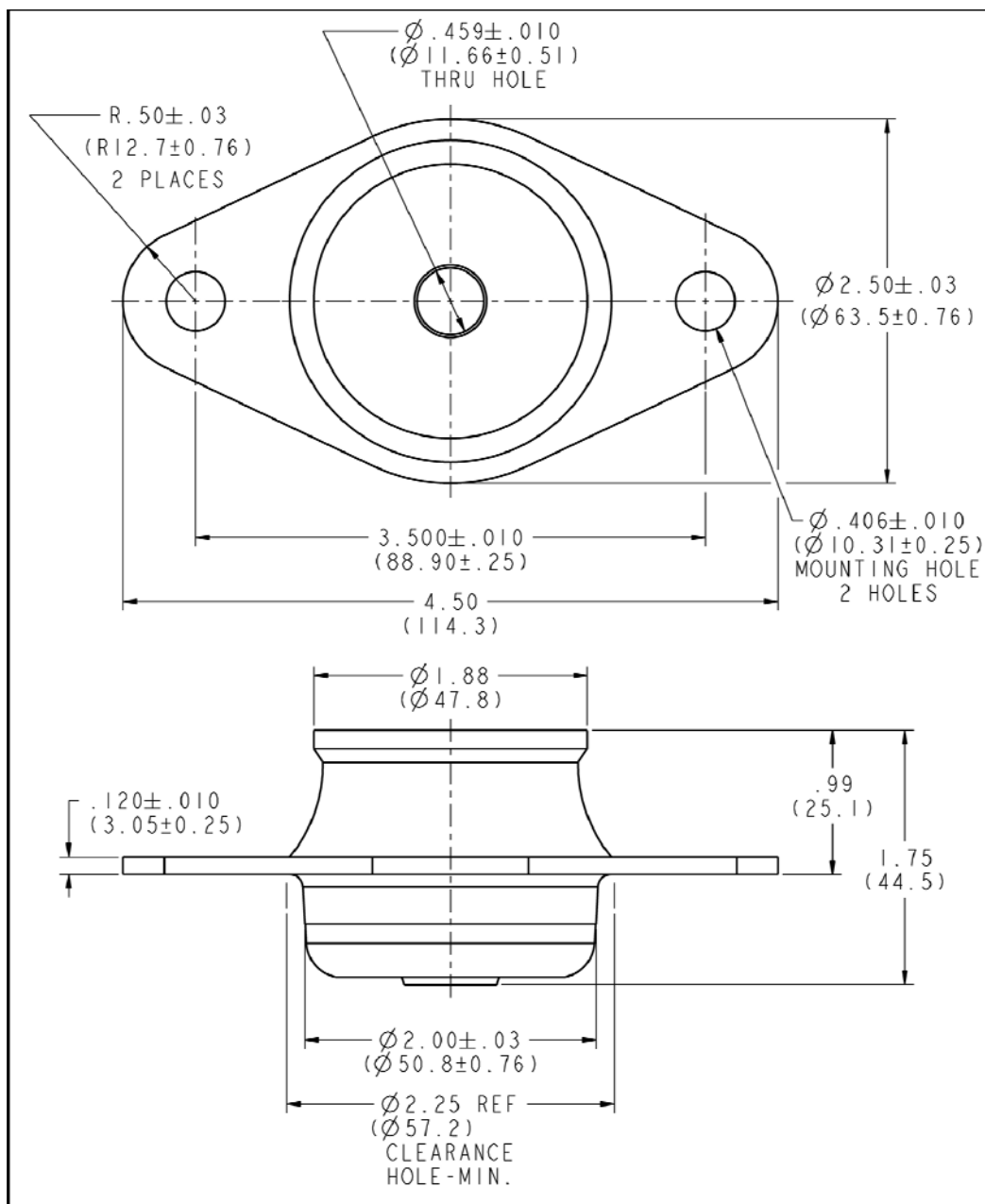

Fail-Safe Compression Mount Series: 1753

Dimension and Performance Characteristics

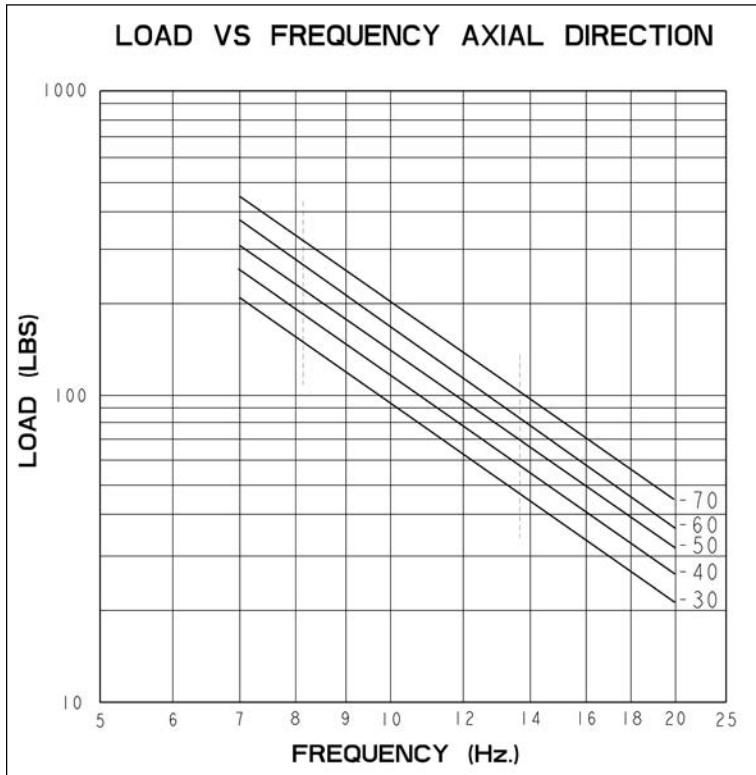

SNUBBING WASHER

P/N SW-2000-0450-0125-SZ

O.D. = \varnothing 2.00"

I.D. = \varnothing .450"

THICKNESS = .125"

MATERIAL—1010-1020 CRS

FINISH—CLEAR ZINC

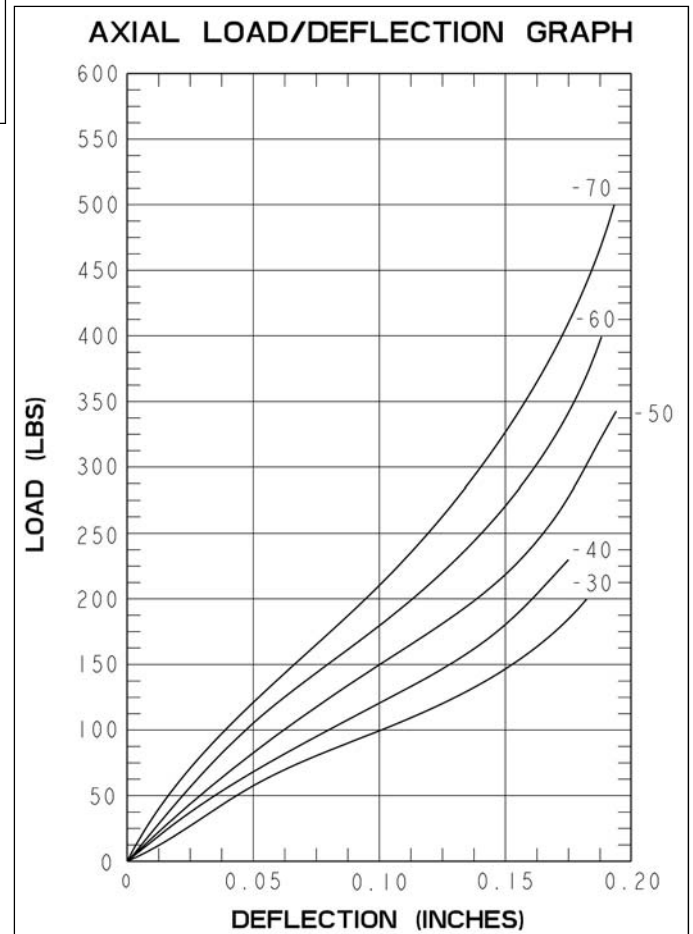

Fail-Safe Compression Mount Series: 1754

Dimension and Performance Characteristics

Part #	Nominal Axial Load (lbs.)	Max. Axial Load (lbs.)	Axial Stiffness at .10" Deflection (lbs./in.)	Radial Static Load Nominal	Radial Static Load Max.	Radial Stiffness at .10" Deflection (lbs./in.)	Transmissibility	Free Height (max. in.)	Resilient Materials	Structural Materials	Finish	Core Style	Center Hole	Flange Hole	Color Code
1754-30	180	270	1800	90	180	900	10:1	2.00	Neoprene	Steel	Zinc	Thru Hole	.531	.406	Red
1754-40	220	330	2200	110	220	1100	10:1	2.00	Neoprene	Steel	Zinc	Thru Hole	.531	.406	Orange
1754-50	260	390	2600	130	260	1300	10:1	2.00	Neoprene	Steel	Zinc	Thru Hole	.531	.406	Yellow
1754-60	320	480	3200	160	320	1600	10:1	2.00	Neoprene	Steel	Zinc	Thru Hole	.531	.406	Green
1754-70	380	570	3800	190	380	1900	10:1	2.00	Neoprene	Steel	Zinc	Thru Hole	.531	.406	Blue
1754-30BP	180	270	1800	90	180	900	10:1	2.00	Neoprene	Steel	Black Paint	Thru Hole	.531	.406	Red
1754-40BP	220	330	2200	110	220	1100	10:1	2.00	Neoprene	Steel	Black Paint	Thru Hole	.531	.406	Orange
1754-50BP	260	390	2600	130	260	1300	10:1	2.00	Neoprene	Steel	Black Paint	Thru Hole	.531	.406	Yellow
1754-60BP	320	480	3200	160	320	1600	10:1	2.00	Neoprene	Steel	Black Paint	Thru Hole	.531	.406	Green
1754-70BP	380	570	3800	190	380	1900	10:1	2.00	Neoprene	Steel	Black Paint	Thru Hole	.531	.406	Blue
1754-30EN	180	270	1800	90	180	900	10:1	2.00	Neoprene	Steel	Electroless Nickel	Thru Hole	.531	.406	Red
1754-40EN	220	330	2200	110	220	1100	10:1	2.00	Neoprene	Steel	Electroless Nickel	Thru Hole	.531	.406	Orange
1754-50EN	260	390	2600	130	260	1300	10:1	2.00	Neoprene	Steel	Electroless Nickel	Thru Hole	.531	.406	Yellow
1754-60EN	320	480	3200	160	320	1600	10:1	2.00	Neoprene	Steel	Electroless Nickel	Thru Hole	.531	.406	Green
1754-70EN	380	570	3800	190	380	1900	10:1	2.00	Neoprene	Steel	Electroless Nickel	Thru Hole	.531	.406	Blue

Fail-Safe Compression Mount Series: 1754

Dimension and Performance Characteristics

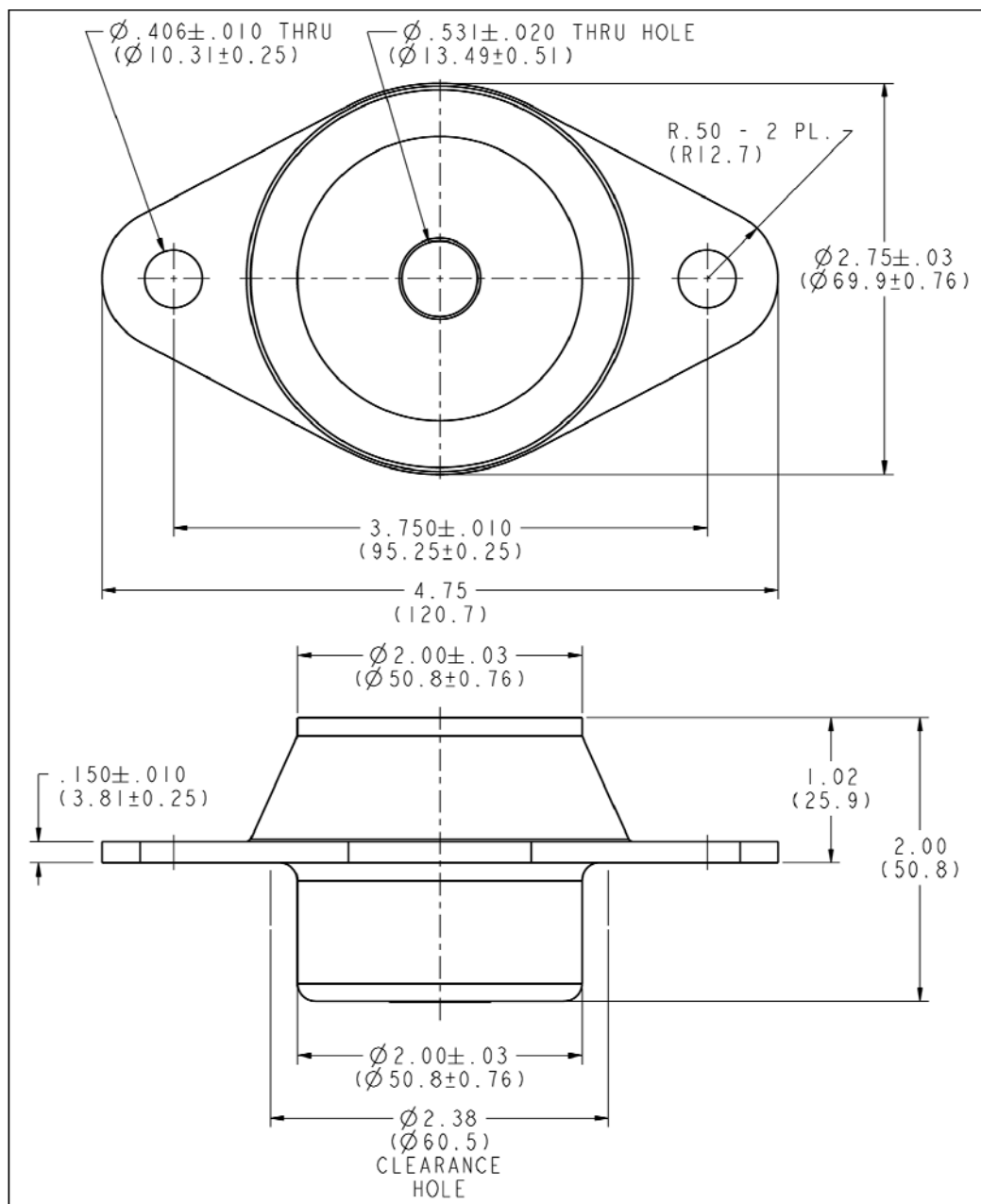

H

Fail-Safe Compression Mount Series: 1754

Dimension and Performance Characteristics

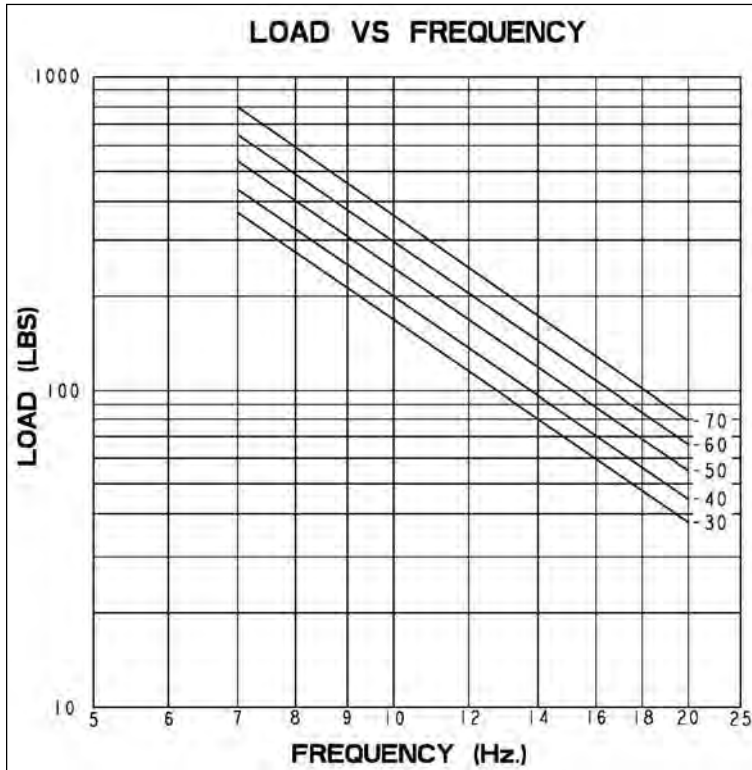

SNUBBING WASHER
P/N SW-2000-0510-0125-SZ
O.D. = Ø 2.00"
I.D. = Ø .510"
THICKNESS = .125"
MATERIAL—1010-1020 CRS
FINISH—CLEAR ZINC

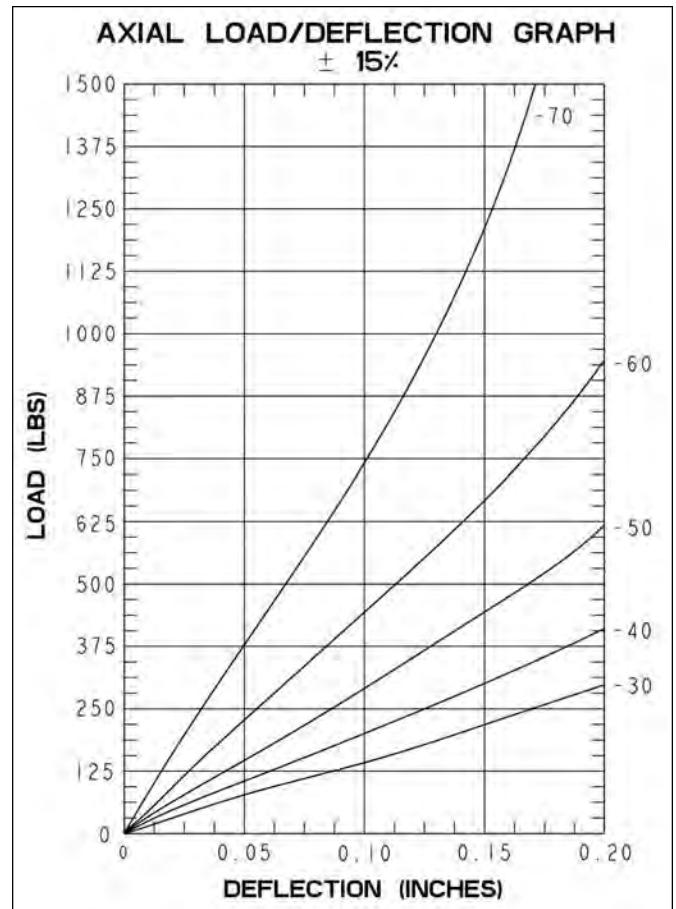

Fail-Safe Compression Mount Series: 1755

Dimension and Performance Characteristics



Part #	Nominal Axial Load (lbs.)	Max. Axial Load (lbs.)	Axial Stiffness at .10" Deflection (lbs./in.)	Radial Static Load Nominal	Radial Static Load Max.	Radial Stiffness at .10" Deflection (lbs./in.)	Transmissibility	Free Height (max. in.)	Resilient Materials	Structural Materials	Finish	Core Style	Center Hole	Flange Hole	Color Code
1755-30	320	480	3200	150	320	1500	10:1	2.25	Neoprene	Steel	Zinc	Thru Hole	.687	.406	Red
1755-40	380	570	3800	190	380	1900	10:1	2.25	Neoprene	Steel	Zinc	Thru Hole	.687	.406	Orange
1755-50	460	690	4600	230	460	2300	10:1	2.25	Neoprene	Steel	Zinc	Thru Hole	.687	.406	Yellow
1755-60	560	840	5600	280	560	2800	10:1	2.25	Neoprene	Steel	Zinc	Thru Hole	.687	.406	Green
1755-70	680	1020	6800	340	680	3400	10:1	2.25	Neoprene	Steel	Zinc	Thru Hole	.687	.406	Blue
1755-30BP	320	480	3200	150	320	1500	10:1	2.25	Neoprene	Steel	Black Paint	Thru Hole	.687	.406	Red
1755-40BP	380	570	3800	190	380	1900	10:1	2.25	Neoprene	Steel	Black Paint	Thru Hole	.687	.406	Orange
1755-50BP	460	690	4600	230	460	2300	10:1	2.25	Neoprene	Steel	Black Paint	Thru Hole	.687	.406	Yellow
1755-60BP	560	840	5600	280	560	2800	10:1	2.25	Neoprene	Steel	Black Paint	Thru Hole	.687	.406	Green
1755-70BP	680	1020	6800	340	680	3400	10:1	2.25	Neoprene	Steel	Black Paint	Thru Hole	.687	.406	Blue
1755-30EN	320	480	3200	150	320	1500	10:1	2.25	Neoprene	Steel	Electroless Nickel	Thru Hole	.687	.406	Red
1755-40EN	380	570	3800	190	380	1900	10:1	2.25	Neoprene	Steel	Electroless Nickel	Thru Hole	.687	.406	Orange
1755-50EN	460	690	4600	230	460	2300	10:1	2.25	Neoprene	Steel	Electroless Nickel	Thru Hole	.687	.406	Yellow
1755-60EN	560	840	5600	280	560	2800	10:1	2.25	Neoprene	Steel	Electroless Nickel	Thru Hole	.687	.406	Green
1755-70EN	680	1020	6800	340	680	3400	10:1	2.25	Neoprene	Steel	Electroless Nickel	Thru Hole	.687	.406	Blue

Fail-Safe Compression Mount Series: 1755

Dimension and Performance Characteristics

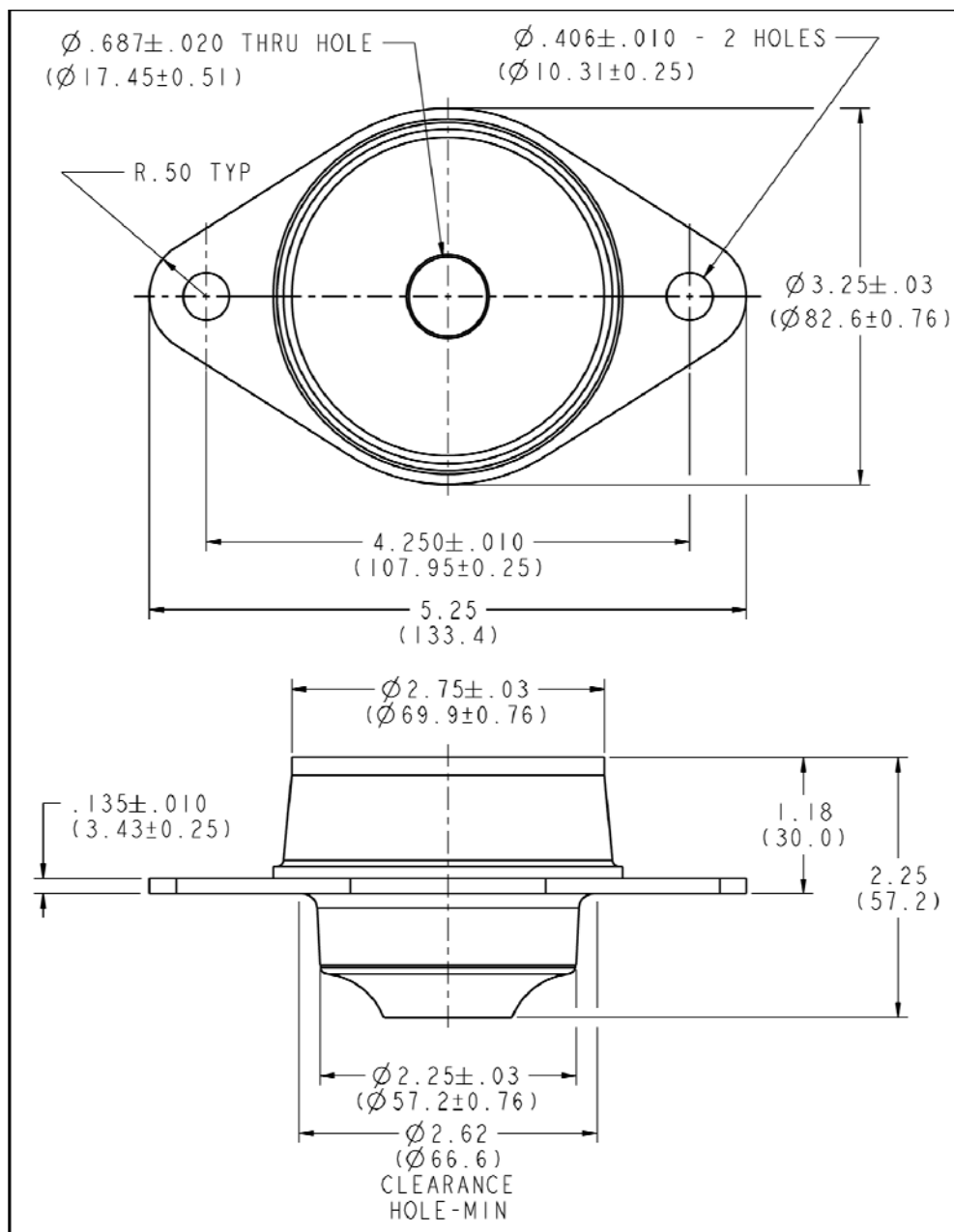

Fail-Safe Compression Mount Series: 1755

Dimension and Performance Characteristics

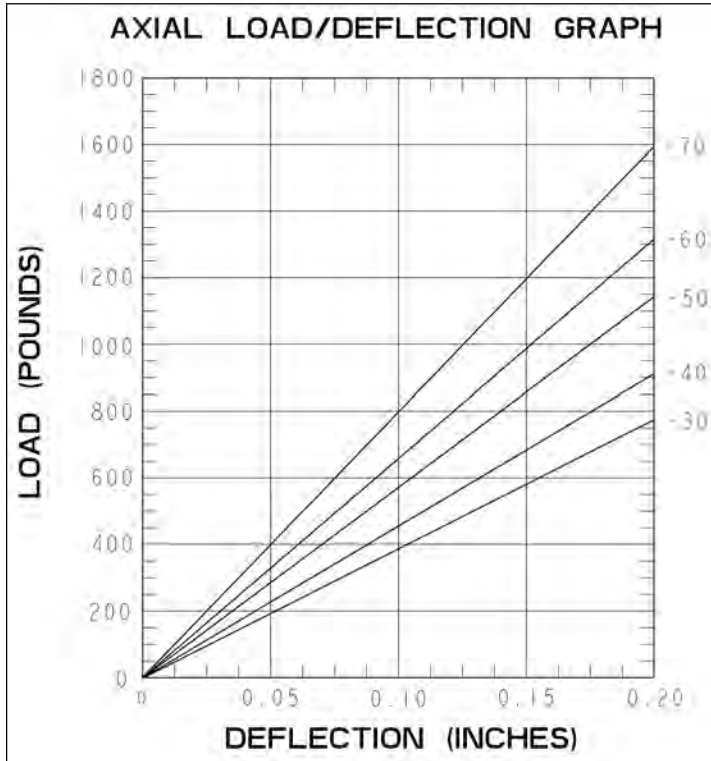

SNUBBING WASHER
P/N SW-2250-0635-0150-SZ
O.D. = Ø 2.25"
I.D. = Ø .635"
THICKNESS = .150"
MATERIAL—1010-1020 CRS
FINISH—CLEAR ZINC

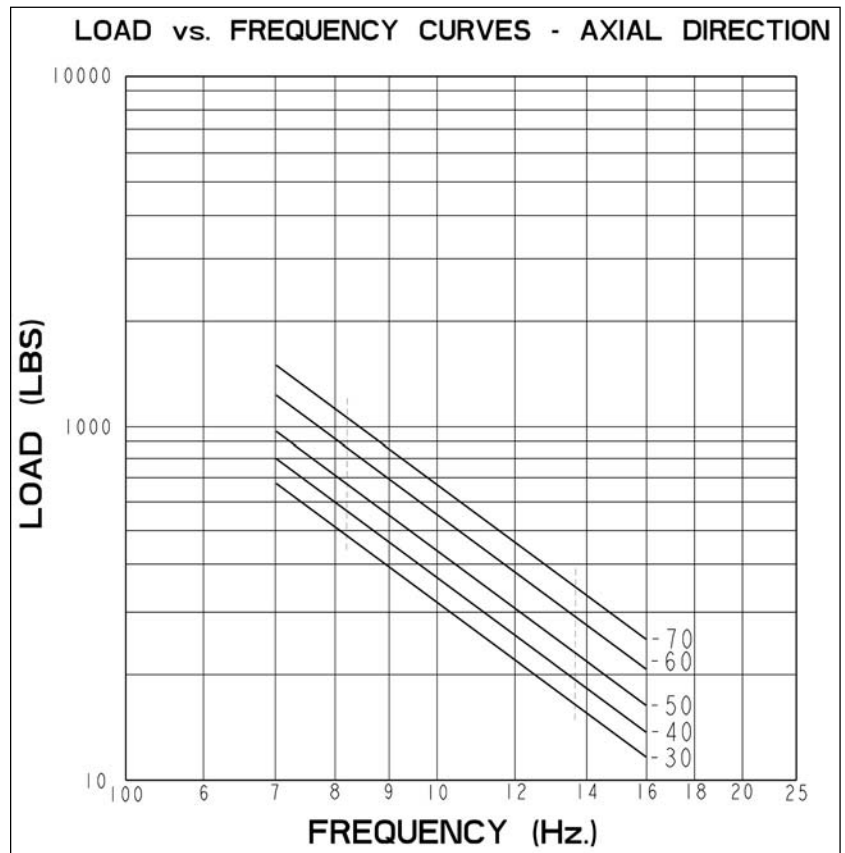

Fail-Safe Compression Mount Series: 1756

Dimension and Performance Characteristics

Part #	Nominal Axial Load (lbs.)	Max. Axial Load (lbs.)	Axial Stiffness at .10" Deflection (lbs./in.)	Radial Static Load Nominal	Radial Static Load Max.	Radial Stiffness at .10" Deflection (lbs./in.)	Transmissibility	Free Height (max. in.)	Resilient Materials	Structural Materials	Finish	Core Style	Center Hole	Flange Hole	Color Code
1756-30	460	690	4600	230	450	2300	10:1	3.00	Neoprene	Steel	Zinc	Thru Hole	.794	.531	Red
1756-40	560	840	5600	280	560	2800	10:1	3.00	Neoprene	Steel	Zinc	Thru Hole	.794	.531	Orange
1756-50	680	1020	6800	340	680	3400	10:1	3.00	Neoprene	Steel	Zinc	Thru Hole	.794	.531	Yellow
1756-60	830	1245	8300	415	830	4150	10:1	3.00	Neoprene	Steel	Zinc	Thru Hole	.794	.531	Green
1756-70	1000	1500	10000	500	1000	5000	10:1	3.00	Neoprene	Steel	Zinc	Thru Hole	.794	.531	Blue
1756-30BP	460	690	4600	230	450	2300	10:1	3.00	Neoprene	Steel	Black Paint	Thru Hole	.794	.531	Red
1756-40BP	560	840	5600	280	560	2800	10:1	3.00	Neoprene	Steel	Black Paint	Thru Hole	.794	.531	Orange
1756-50BP	680	1020	6800	340	680	3400	10:1	3.00	Neoprene	Steel	Black Paint	Thru Hole	.794	.531	Yellow
1756-60BP	830	1245	8300	415	830	4150	10:1	3.00	Neoprene	Steel	Black Paint	Thru Hole	.794	.531	Green
1756-70BP	1000	1500	10000	500	1000	5000	10:1	3.00	Neoprene	Steel	Black Paint	Thru Hole	.794	.531	Blue
1756-30EN	460	690	4600	230	450	2300	10:1	3.00	Neoprene	Steel	Electroless Nickel	Thru Hole	.794	.531	Red
1756-40EN	560	840	5600	280	560	2800	10:1	3.00	Neoprene	Steel	Electroless Nickel	Thru Hole	.794	.531	Orange
1756-50EN	680	1020	6800	340	680	3400	10:1	3.00	Neoprene	Steel	Electroless Nickel	Thru Hole	.794	.531	Yellow
1756-60EN	830	1245	8300	415	830	4150	10:1	3.00	Neoprene	Steel	Electroless Nickel	Thru Hole	.794	.531	Green
1756-70EN	1000	1500	10000	500	1000	5000	10:1	3.00	Neoprene	Steel	Electroless Nickel	Thru Hole	.794	.531	Blue

Fail-Safe Compression Mount Series: 1756

Dimension and Performance Characteristics

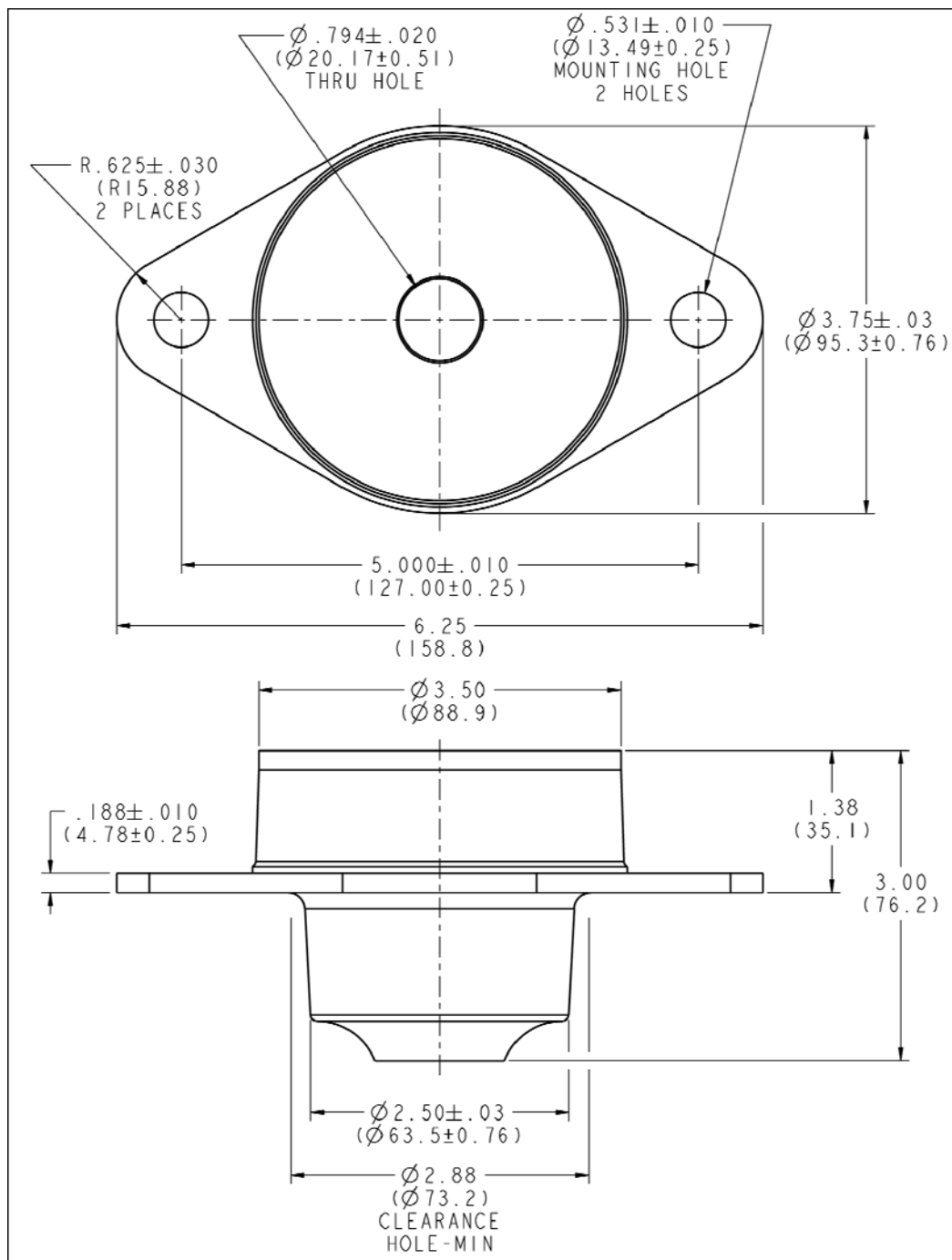

H

Fail-Safe Compression Mount Series: 1756

Dimension and Performance Characteristics

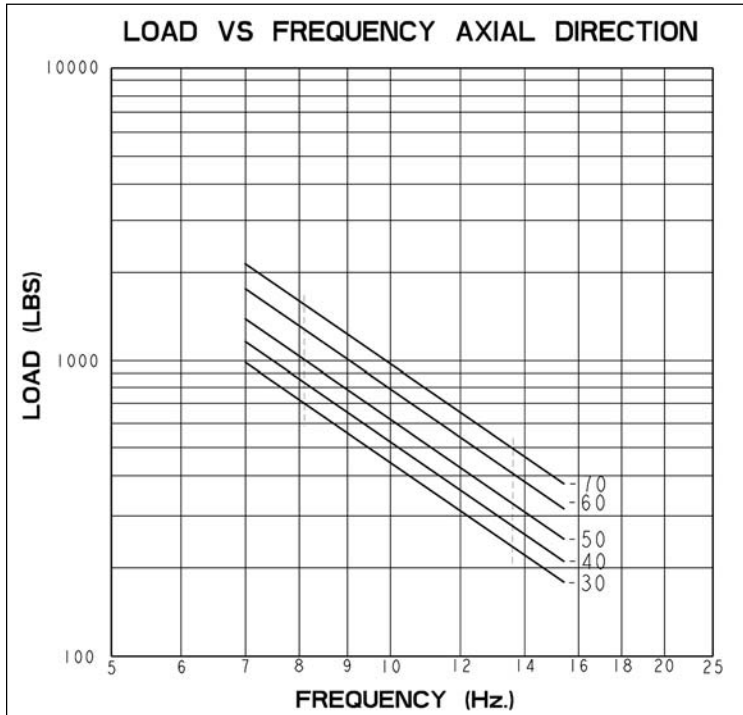

SNUBBING WASHER
P/N SW-2500-0780-0188-SZ
O.D. = Ø 2.50"
I.D. = Ø .780"
THICKNESS = .188"
MATERIAL—1010-1020 CRS
FINISH—CLEAR ZINC

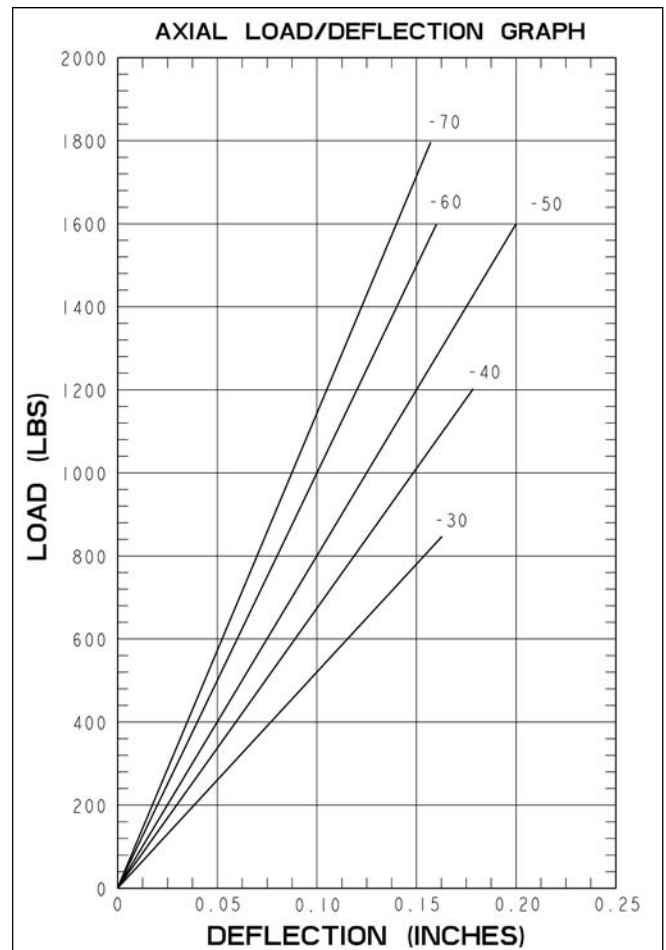

Fail-Safe Compression Mount Series: 1757

Dimension and Performance Characteristics



Part #	Nominal Axial Load (lbs.)	Max. Axial Load (lbs.)	Axial Stiffness at .10" Deflection (lbs./in.)	Radial Static Load Nominal	Radial Static Load Max.	Radial Stiffness at .10" Deflection (lbs./in.)	Transmissibility	Free Height (max. in.)	Resilient Materials	Structural Materials	Finish	Core Style	Center Hole	Flange Hole	Color Code
1757-30	830	1245	8300	415	830	4150	10:1	4.00	Neoprene	Steel	Zinc	Thru Hole	1.062	.656	Red
1757-40	1000	1500	10000	500	1000	5000	10:1	4.00	Neoprene	Steel	Zinc	Thru Hole	1.062	.656	Orange
1757-50	1210	1815	12100	605	1210	6050	10:1	4.00	Neoprene	Steel	Zinc	Thru Hole	1.062	.656	Yellow
1757-60	1470	2205	14700	735	1470	7350	10:1	4.00	Neoprene	Steel	Zinc	Thru Hole	1.062	.656	Green
1757-70	1780	2700	17800	890	1780	8900	10:1	4.00	Neoprene	Steel	Zinc	Thru Hole	1.062	.656	Blue
1757-30BP	830	1245	8300	415	830	4150	10:1	4.00	Neoprene	Steel	Black Paint	Thru Hole	1.062	.656	Red
1757-40BP	1000	1500	10000	500	1000	5000	10:1	4.00	Neoprene	Steel	Black Paint	Thru Hole	1.062	.656	Orange
1757-50BP	1210	1815	12100	605	1210	6050	10:1	4.00	Neoprene	Steel	Black Paint	Thru Hole	1.062	.656	Yellow
1757-60BP	1470	2205	14700	735	1470	7350	10:1	4.00	Neoprene	Steel	Black Paint	Thru Hole	1.062	.656	Green
1757-70BP	1780	2700	17800	890	1780	8900	10:1	4.00	Neoprene	Steel	Black Paint	Thru Hole	1.062	.656	Blue
1757-30EN	830	1245	8300	415	830	4150	10:1	4.00	Neoprene	Steel	Electroless Nickel	Thru Hole	1.062	.656	Red
1757-40EN	1000	1500	10000	500	1000	5000	10:1	4.00	Neoprene	Steel	Electroless Nickel	Thru Hole	1.062	.656	Orange
1757-50EN	1210	1815	12100	605	1210	6050	10:1	4.00	Neoprene	Steel	Electroless Nickel	Thru Hole	1.062	.656	Yellow
1757-60EN	1470	2205	14700	735	1470	7350	10:1	4.00	Neoprene	Steel	Electroless Nickel	Thru Hole	1.062	.656	Green
1757-70EN	1780	2700	17800	890	1780	8900	10:1	4.00	Neoprene	Steel	Electroless Nickel	Thru Hole	1.062	.656	Blue

Fail-Safe Compression Mount Series: 1757

Dimension and Performance Characteristics

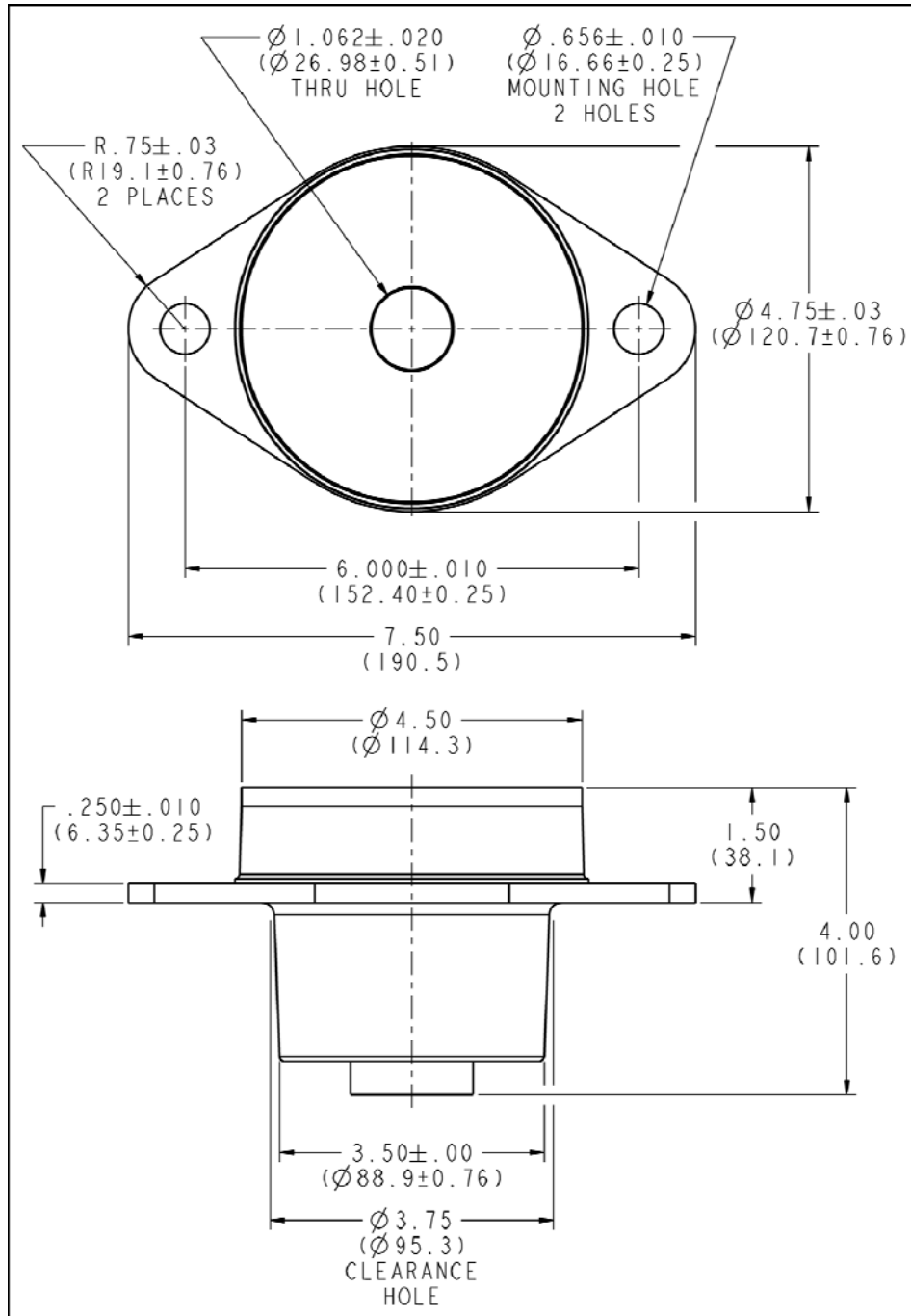

Fail-Safe Compression Mount Series: 1757

Dimension and Performance Characteristics

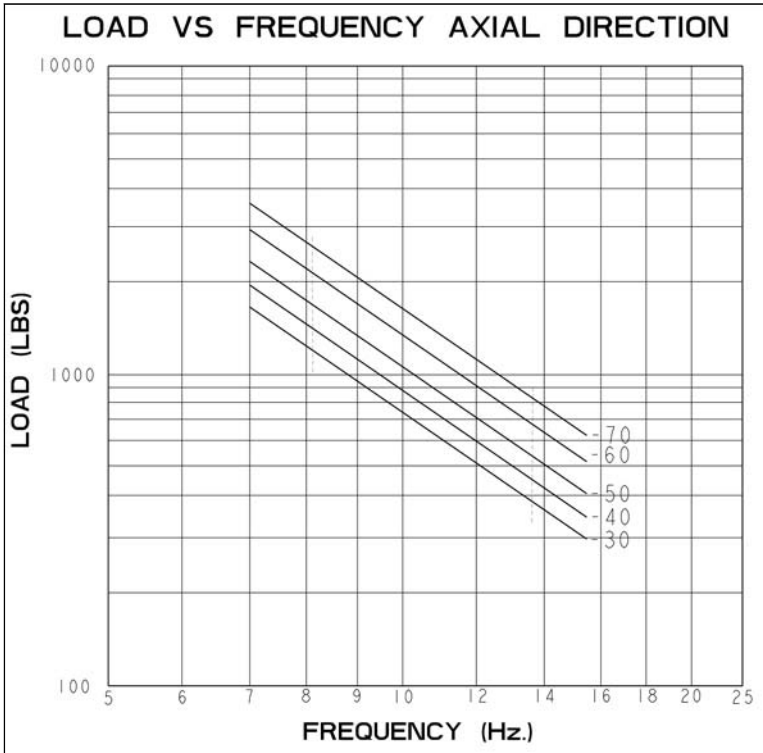

SNUBBING WASHER
P/N SW-3250-1010-0250-SZ
O.D. = \varnothing 3.25"
I.D. = \varnothing 1.01"
THICKNESS = .250"
MATERIAL—1010-1020 CRS
FINISH—CLEAR ZINC

H

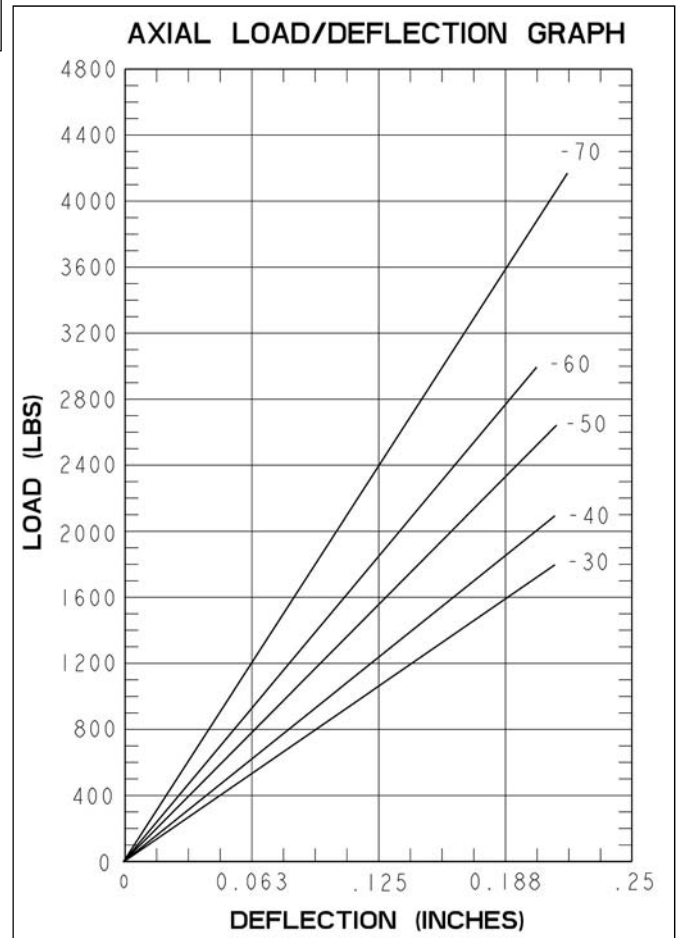

Fail-Safe Compression Mount Series

1804/1805

Compact, fail-safe isolation mounts for 4-cylinder or less diesel engines



Applications

- 1-4 cylinder diesel engines
- Power generation
- Construction equipment
- Agricultural equipment
- Electric motors
- Off road vehicles

Benefits

- Excellent isolation for 1-4 cylinder engines
- Fail-safe construction
- Multiple load ranges that overlap

Attributes

- Rugged construction
- Easy to install
- Axial to radial stiffness of 6:1

Load Range

- 1804 = 5 load ratings to 300 lbs.
- 1805 = 5 load ratings to 420 lbs.

SNUBBING WASHERS

SERIES	P/N	O.D"	I.D"	THICKNESS"	MATERIAL	FINISH
1804	SW-2000-0450-0125-SW	2.00"	.450"	.125"	1010-1020 CRS	Clear Zinc
1805	SW-2130-0532-0134-SW	2.13"	.532"	.134"	1010-1020 CRS	Clear Zinc

Specifications

- Natural Frequency—10-20 Hertz
- Transmissibility at resonance—10:1
- Resilient Element—Neoprene
- Standard materials—Zinc plated steel
- Weight— 1804 = 7 oz. / 1805 = 9 oz.

Elastomeric Data

- Neoprene elastomer has an operating temperature range of -40°F to 200°F (-40°C to +93°C) and is resistant to most solvents, oils and ozone
- Other materials are available upon request

Fail-Safe Compression Mount Series: 1804

Dimension and Performance Characteristics

Part #	Nominal Axial Load (lbs.)	Axial Stiffness at .10" Deflection (lbs./in.)	Transmissibility	Free Height (max. in.)	Resilient Materials	Structural Materials	Core Style	Center Hole	Flange Hole	Color Code
1804-1	50	500	10:1	1.25	Neoprene	Steel	Thru Hole	.396	.340	Red
1804-3	90	900	10:1	1.25	Neoprene	Steel	Thru Hole	.396	.340	Orange
1804-5	150	1500	10:1	1.25	Neoprene	Steel	Thru Hole	.396	.340	Yellow
1804-7	215	2150	10:1	1.25	Neoprene	Steel	Thru Hole	.396	.340	Green
1804-9	300	3000	10:1	1.25	Neoprene	Steel	Thru Hole	.396	.340	Blue

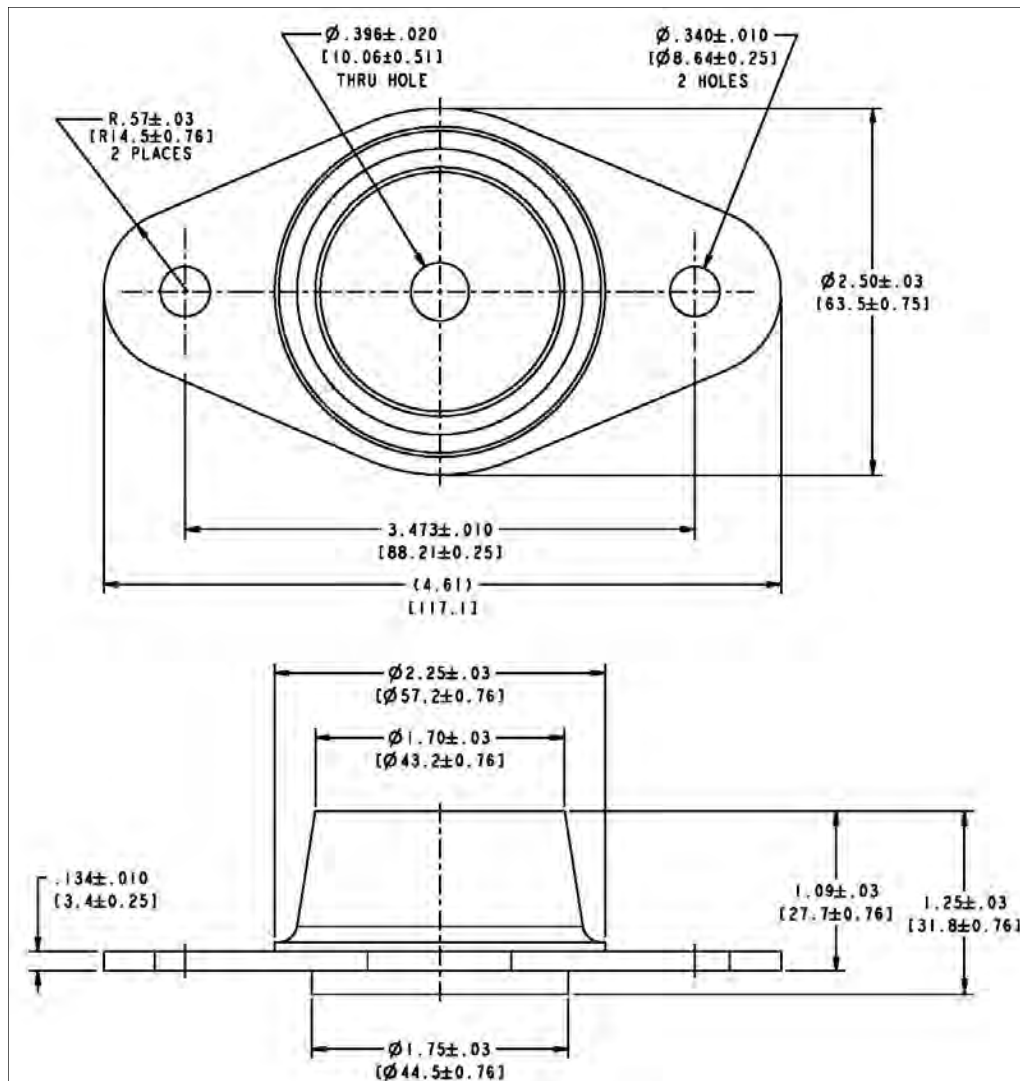

Fail-Safe Compression Mount Series: 1804

Dimension and Performance Characteristics

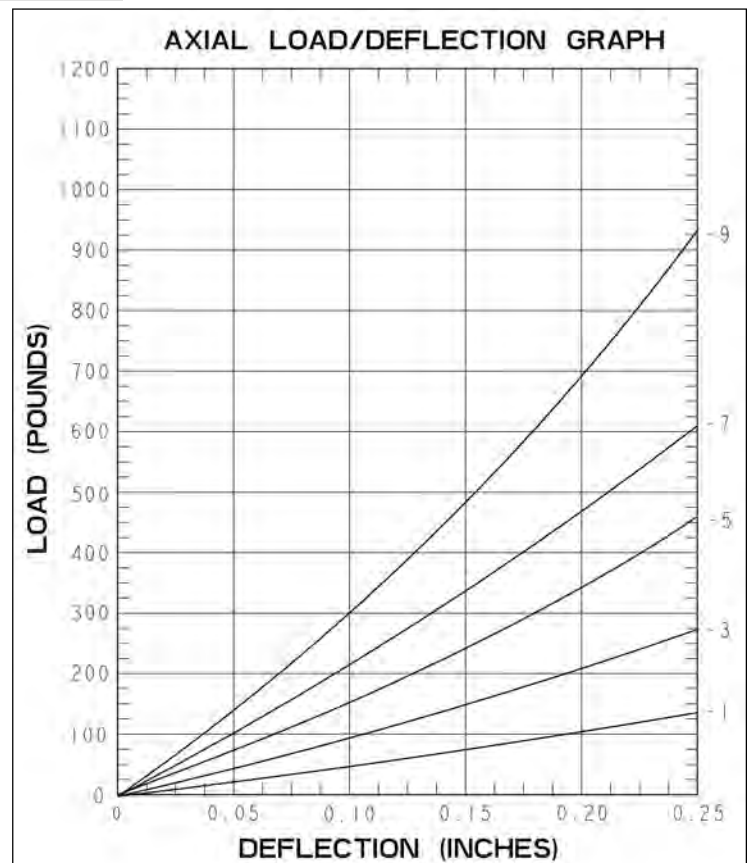
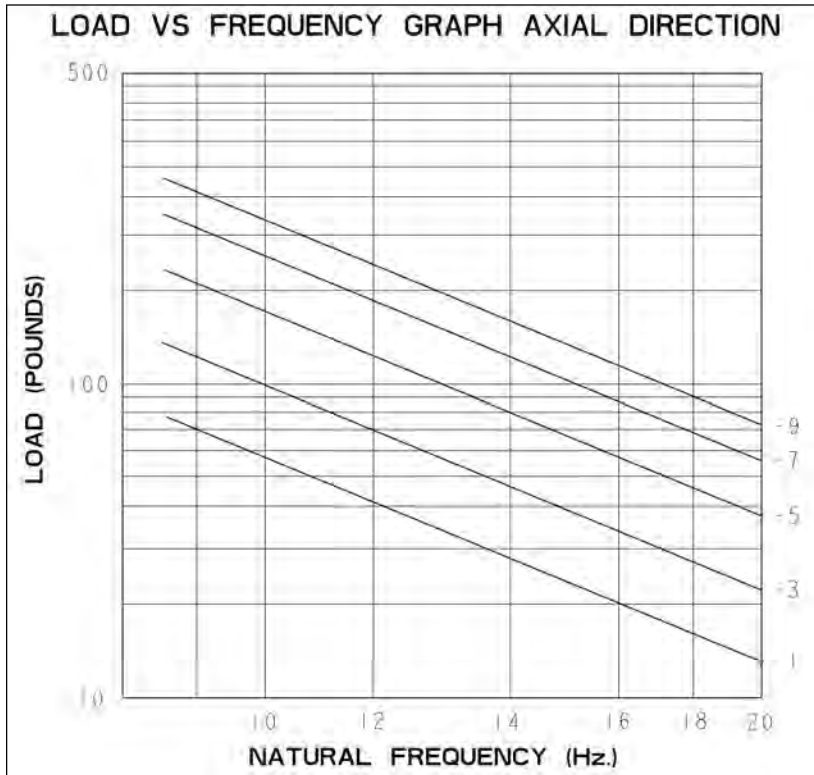

Fail-Safe Compression Mount Series: 1805

Dimension and Performance Characteristics

Part #	Nominal Axial Load (lbs.)	Axial Stiffness at .10" Deflection (lbs./in.)	Transmissibility	Free Height (max. in.)	Resilient Materials	Structural Materials	Core Style	Center Hole	Flange Hole	Color Code
1805-2	100	1000	10:1	1.25	Neoprene	Steel	Thru Hole	.532	.390	Yellow
1805-4	155	1550	10:1	1.25	Neoprene	Steel	Thru Hole	.532	.390	Red
1805-6	230	2300	10:1	1.25	Neoprene	Steel	Thru Hole	.532	.390	Green
1805-8	320	3200	10:1	1.25	Neoprene	Steel	Thru Hole	.532	.390	Blue
1805-10	420	4200	10:1	1.25	Neoprene	Steel	Thru Hole	.532	.390	White

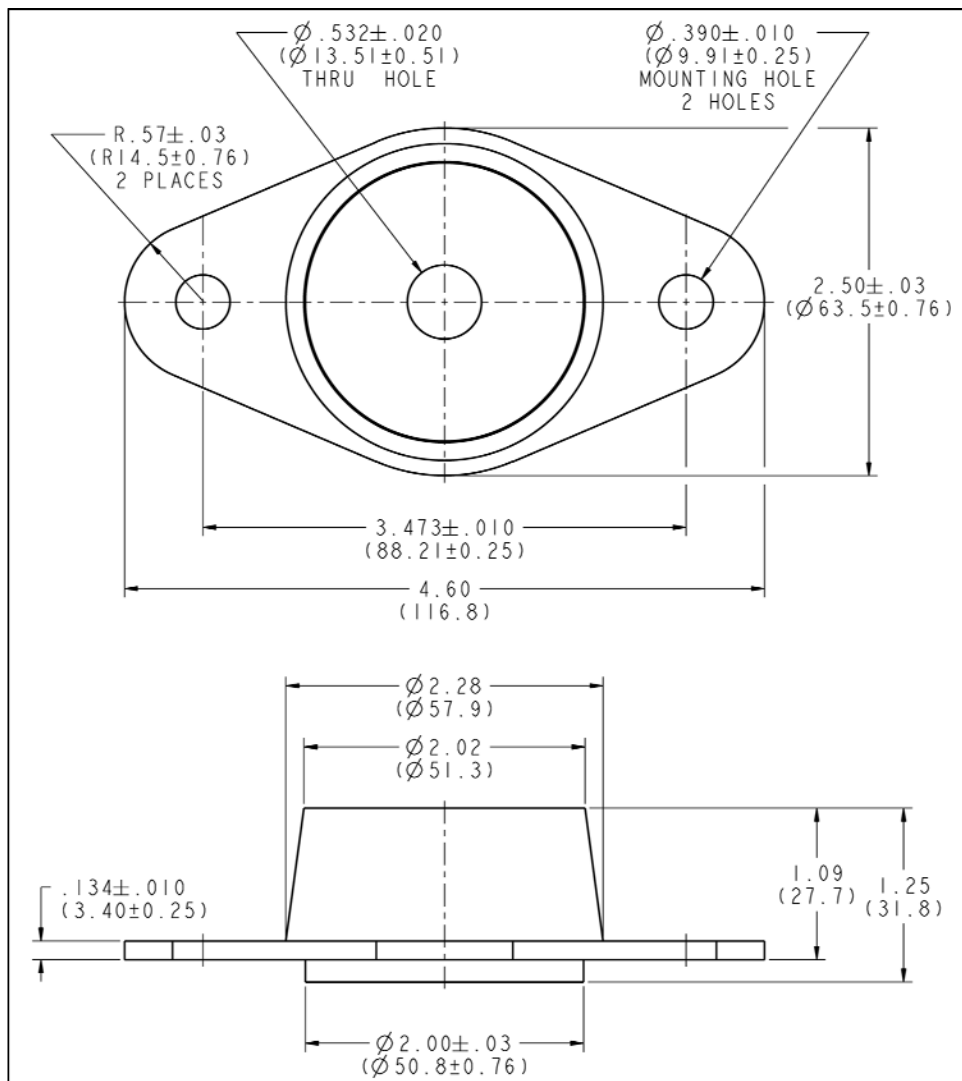

Fail-Safe Compression Mount Series: 1805

Dimension and Performance Characteristics

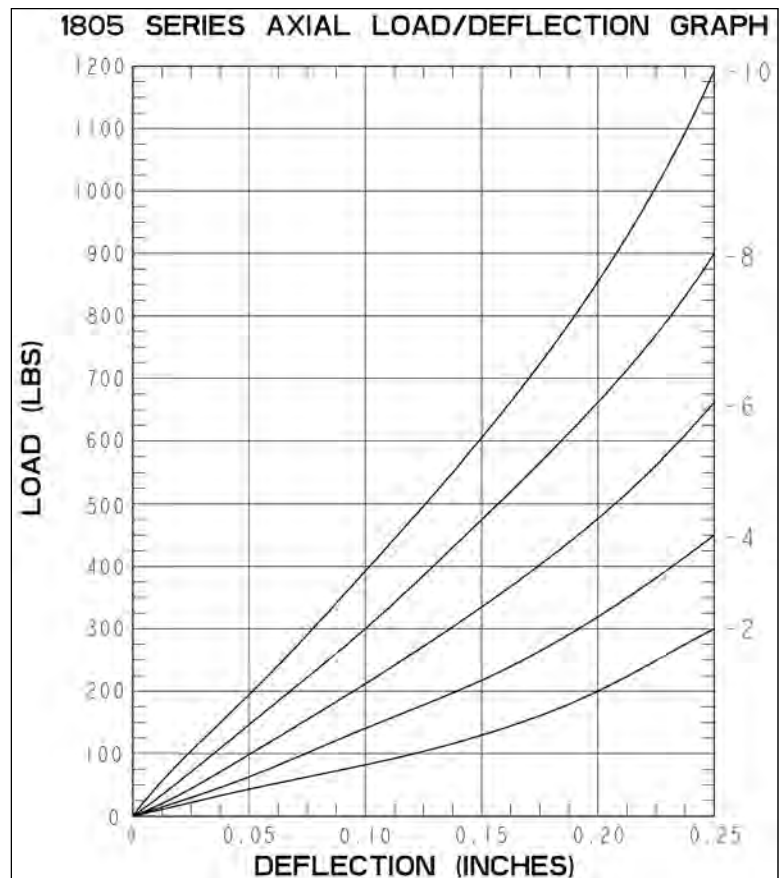
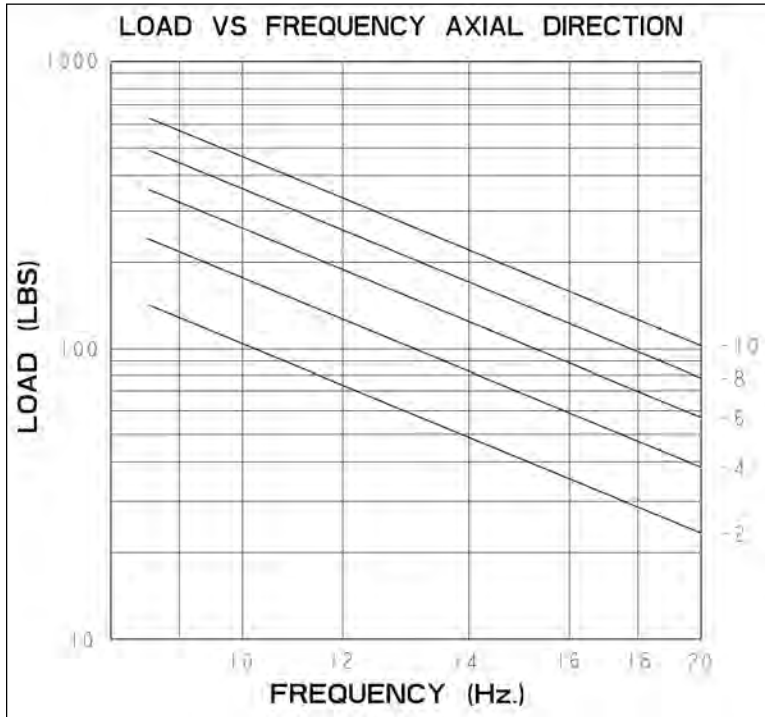

FLUID MOUNT SERIES



1962 Fluid Mount Series

A compact, low frequency, highly damped large deflection mount for protection from severe vibration and shock loads



Attributes

- Silicone gel produces a high level of damping
- Axial to radial stiffness ratio 1:1
- Compact, low profile design
- Easy to install
- Silicone elastomer
- Stainless steel construction
- Designed for severe ground vehicle vibration inputs
- Outstanding dynamic fatigue life
- Fail-safe with ground strap

Applications

- Military ground vehicle COTS electronics (Mil-810)
- Military wheeled and tracked vehicle applications
- Airborne electronics (Mil-810)
- Shock and vibration applications where a high level of damping is required

Load Range

- Load ratings are 11-17 lbs.
- Can be custom tailored to specific applications

Elastomeric Data

- Silicone operating temperature range is -67°F to $+300^{\circ}\text{F}$ (-55°C to $+150^{\circ}\text{C}$)
- Resistant to fungus, most solvents and ozone
- Other elastomeric formulations are available in Neoprene

Fluid Mount Series: 1962

Dimensions and Load Deflection Curves

Part #	Load Range Vehicular (lbs.)	Load Range Airborne (lbs.)	Axial Natural Frequency (hz)	Standard Material	Standard Elastomer	Transmissibility at Resonance Max.
1962-00	11-17	11-17	6-10	304 SS	Silicone/Silicone Gel	2.5:1

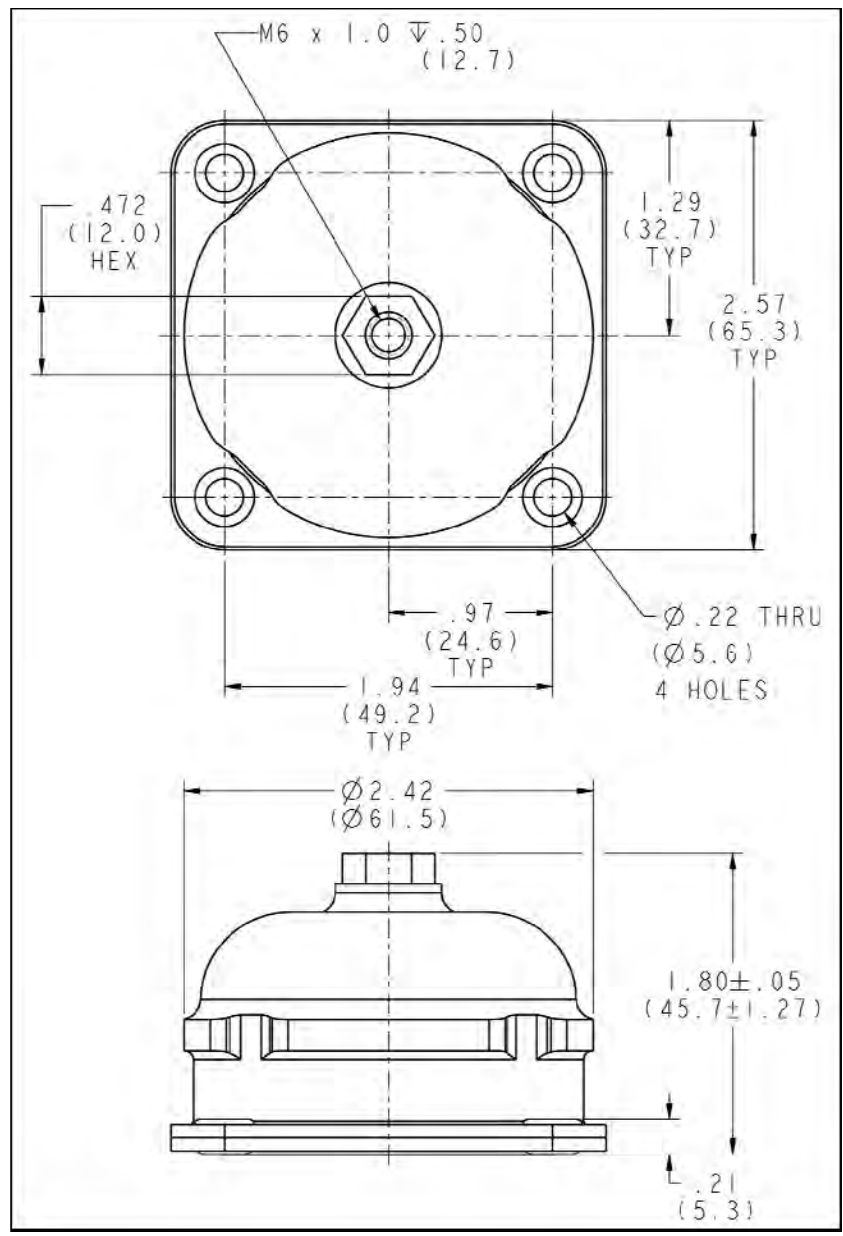

I

Fluid Mount Series: 1962

Dimensions and Load Deflection Curves

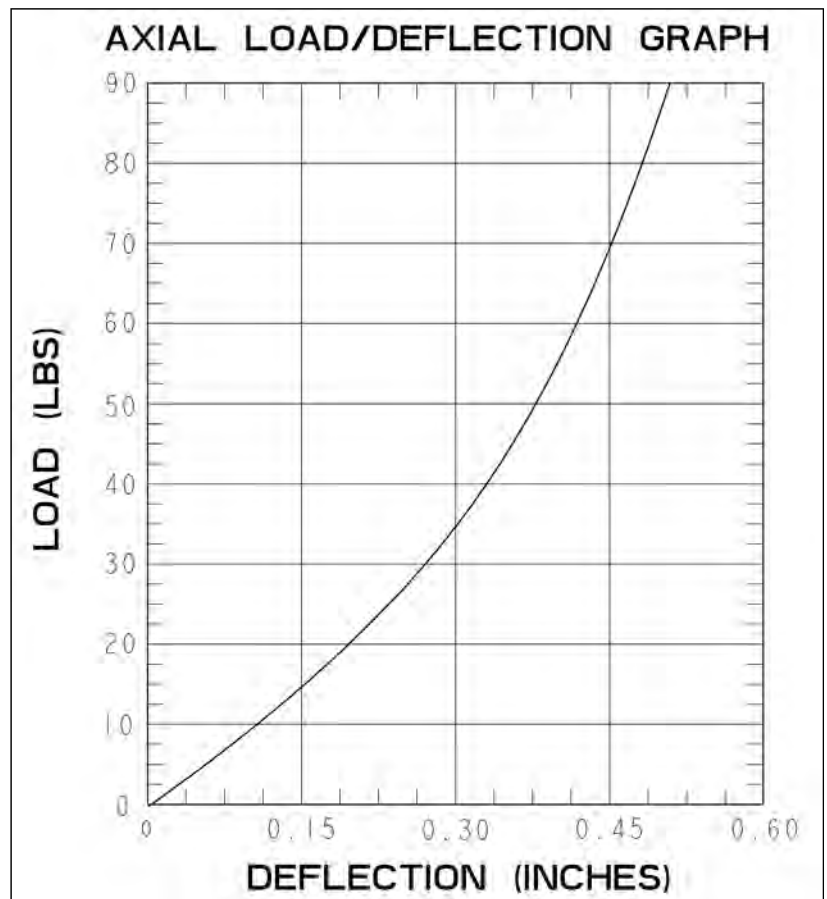
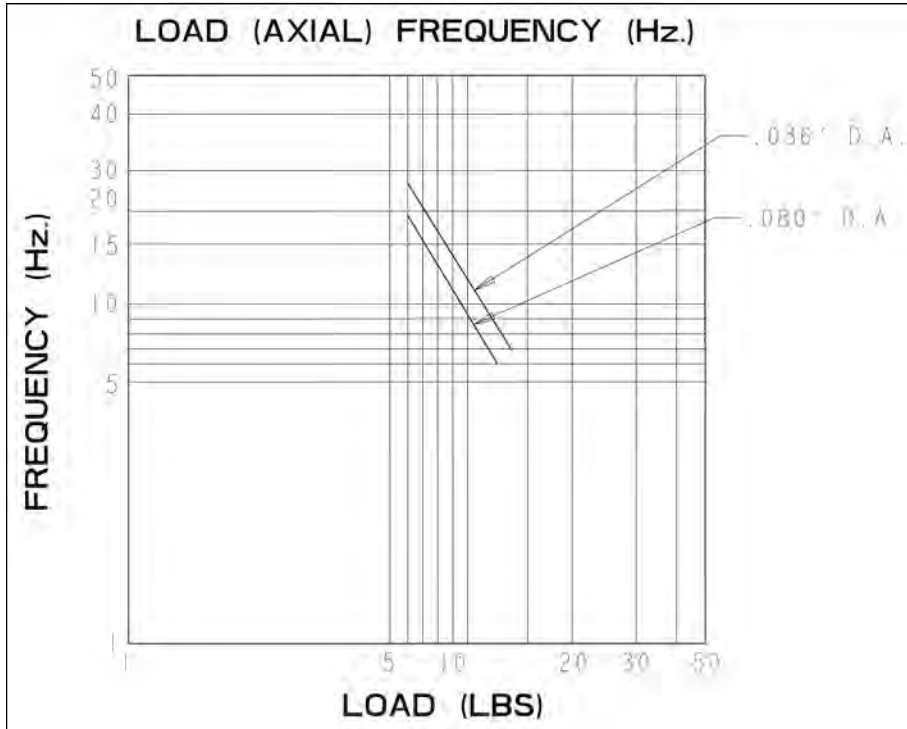

1969 Fluid Mount Series

A compact, low frequency, highly damped large deflection mount for protection from severe vibration and shock loads



Applications

- Military ground vehicle COTS electronics (Mil-810)
- Military wheeled and tracked vehicle applications
- Airborne electronics (Mil-810)
- Shock and vibration applications where a high level of damping is required

I

Load Range

- Load ratings are .5-8 lbs.
- Can be custom tailored to specific applications
- Max axial deflection .57 inches

Attributes

- Silicone gel produces a high level of damping
- Axial to radial stiffness ratio 1:0.8
- Compact, low profile design
- Easy to install
- Silicone elastomer
- Stainless steel construction
- Designed for severe ground vehicle vibration inputs
- Outstanding dynamic fatigue life
- Fail-safe with ground strap

Elastomeric Data

- Silicone operating temperature range is -67°F to +300°F (-55°C to +150°C)
- Resistant to fungus, most solvents and ozone
- Other elastomeric formulations are available in Neoprene

Fluid Mount Series: 1969

Dimensions and Load Deflection Curves

Part #	Load Range Vehicular (lbs.)	Load Range Airborne (lbs.)	Axial Natural Frequency (hz)	Standard Material	Standard Elastomer	Transmissibility at Resonance Max.
1969-00S	3-8	.5-5	10-25	304 SS	Silicone/Silicone Gel	2.5:1
1969-00N	8-18	5-11	10-25	304 SS	Neoprene	10:1

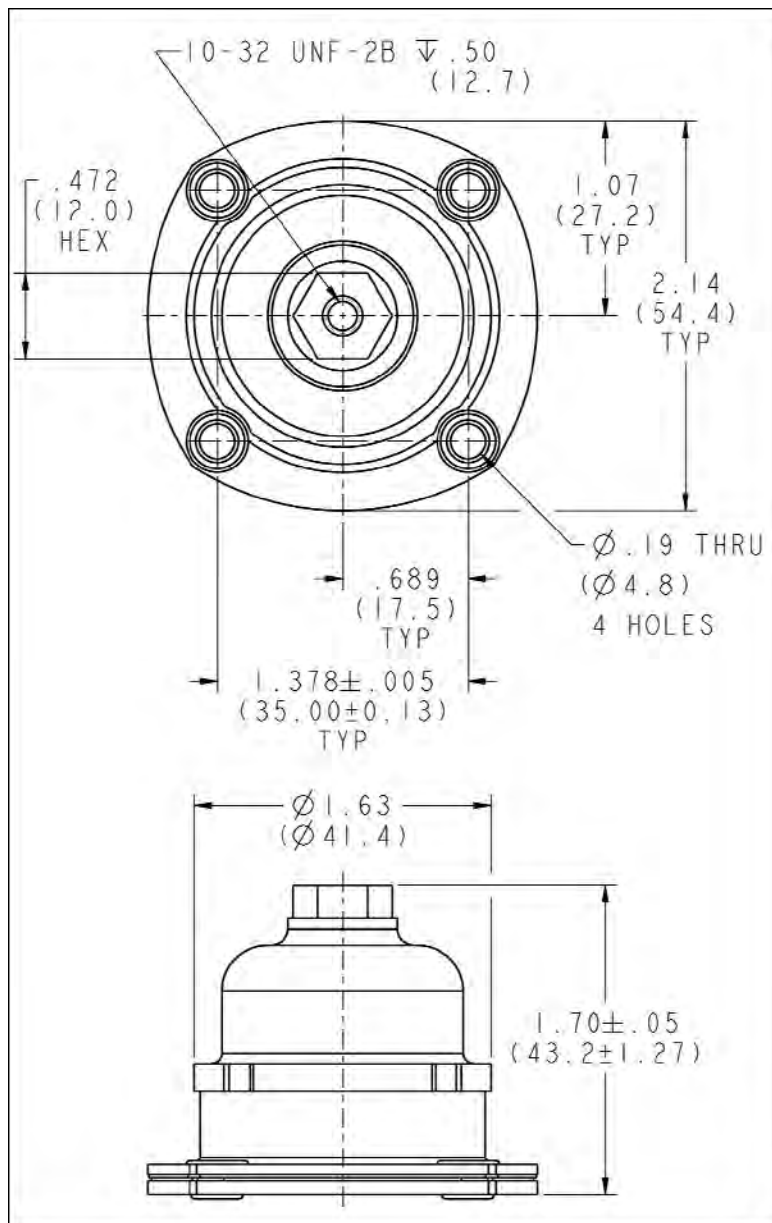

Fluid Mount Series: 1969

Dimensions and Load Deflection Curves

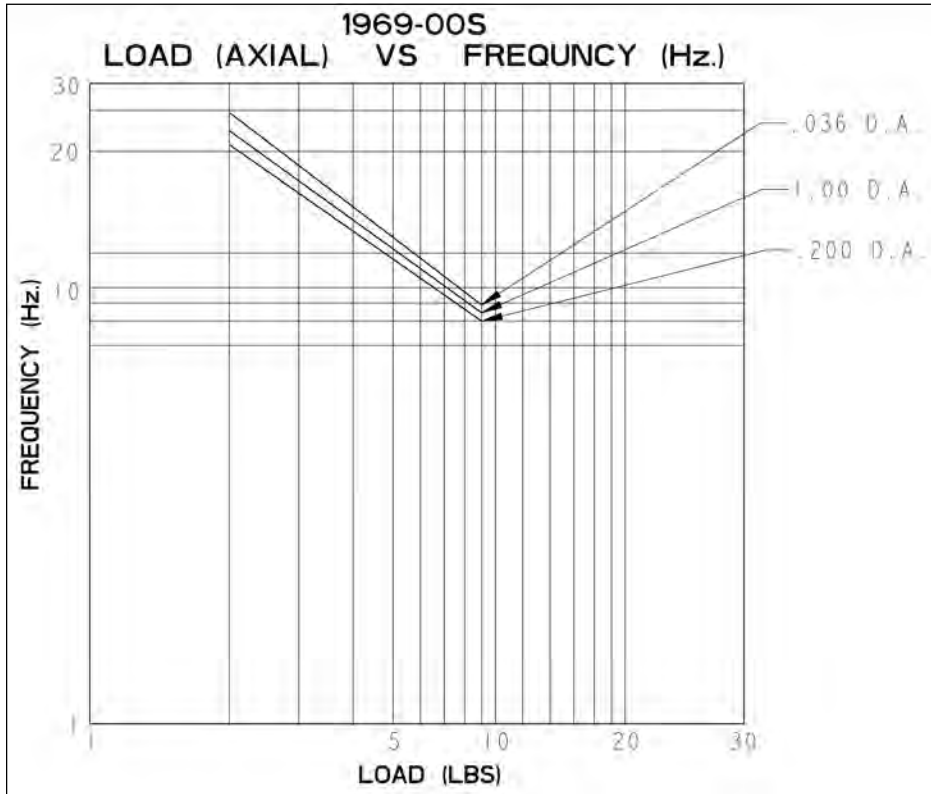

I

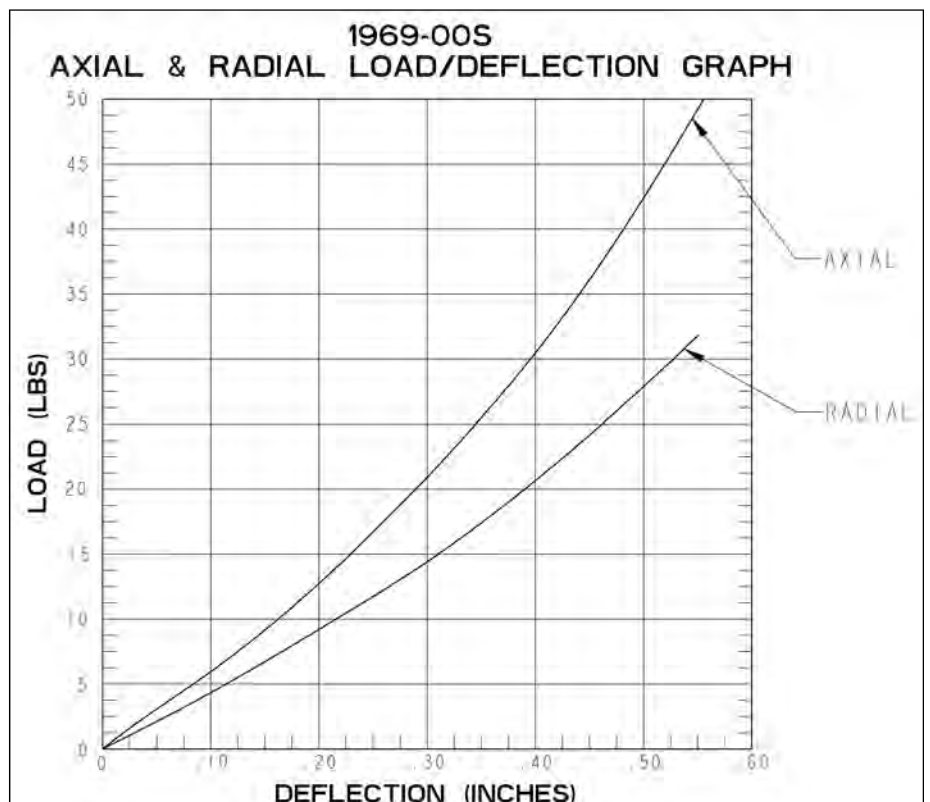

Fluid Mount Series: 1969

Dimensions and Load Deflection Curves

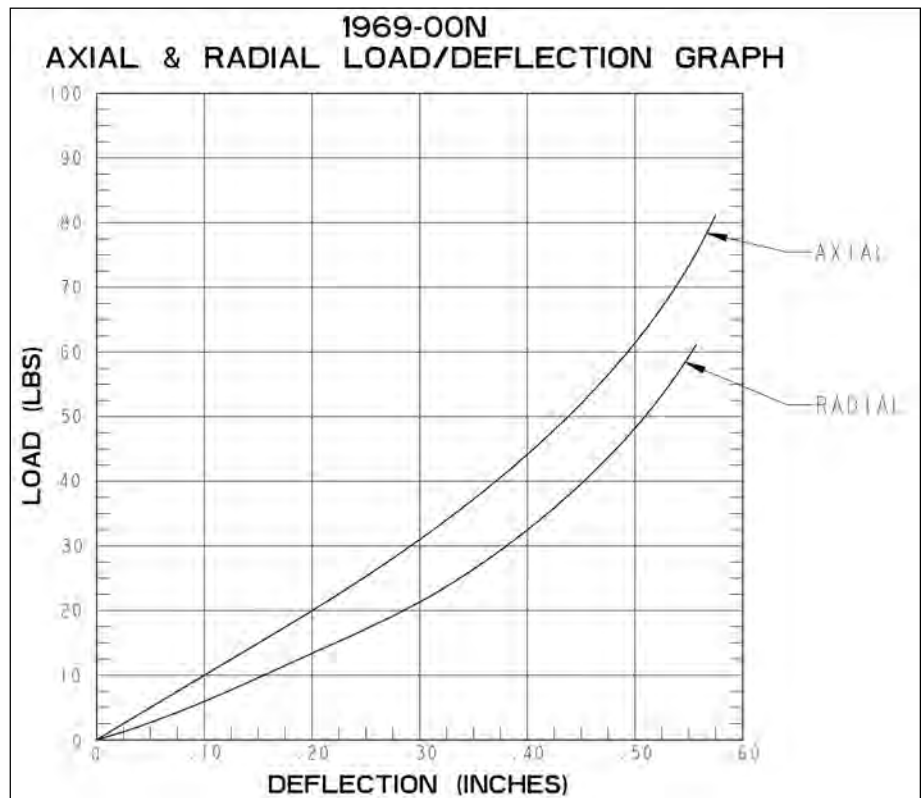
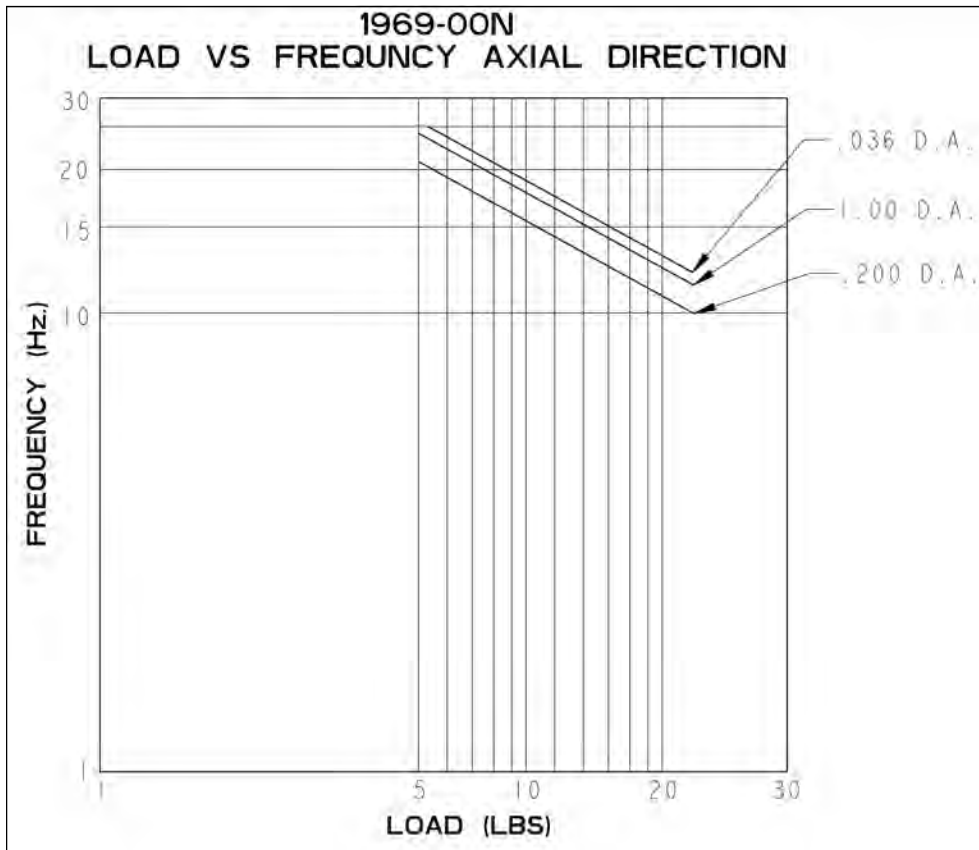

2006 Fluid Mount Series

A compact, low frequency, highly damped large deflection mount for protection from severe vibration and shock loads



Attributes

- Silicone gel produces a high level of damping
- Axial to radial stiffness ratio 1:1
- Compact, low profile design
- Easy to install
- Silicone elastomer
- Stainless steel construction
- Designed for severe ground vehicle vibration inputs
- Outstanding dynamic fatigue life
- Fail-safe with ground strap

Applications

- Military ground vehicle COTS electronics (Mil-810)
- Military wheeled and tracked vehicle applications
- Airborne electronics (Mil-810)
- Shock and vibration applications where a high level of damping is required



Load Range

- Load ratings are 6-11 lbs.
- Can be custom tailored to specific applications
- Max axial deflection .60 inches

Elastomeric Data

- Silicone operating temperature range is -67°F to $+300^{\circ}\text{F}$ (-55°C to $+150^{\circ}\text{C}$)
- Resistant to fungus, most solvents and ozone
- Other elastomeric formulations are available in Neoprene

Fluid Mount Series: 2006

Dimensions and Load Deflection Curves

Part #	Load Range Vehicular (lbs.)	Load Range Airborne (lbs.)	Axial Natural Frequency (hz)	Standard Material	Standard Elastomer	Transmissibility at Resonance Max.
2006-00	6-11	6-11	6-10	304 SS	Silicone/Silicone Gel	2.5:1

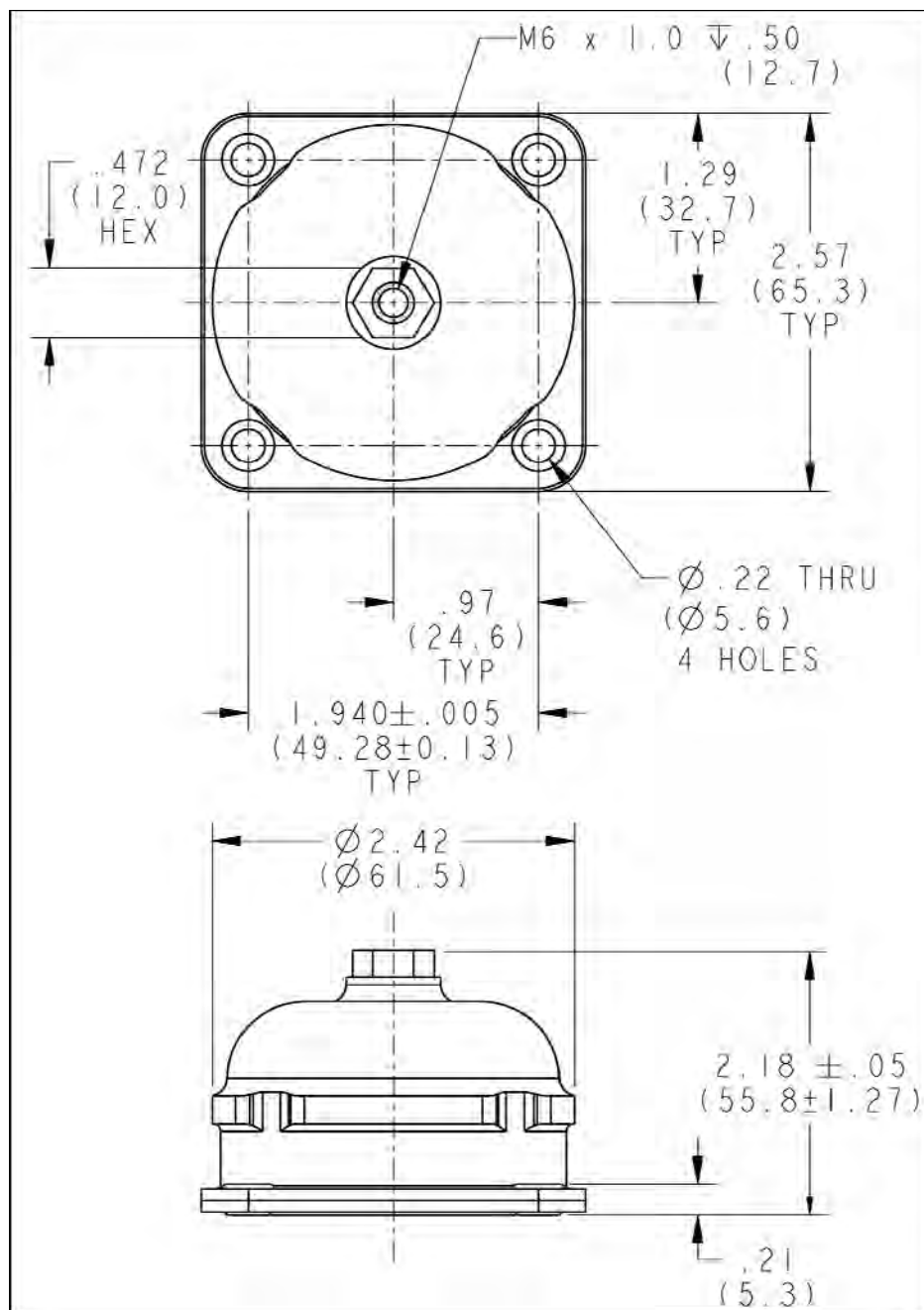

Fluid Mount Series: 2006

Dimensions and Load Deflection Curves

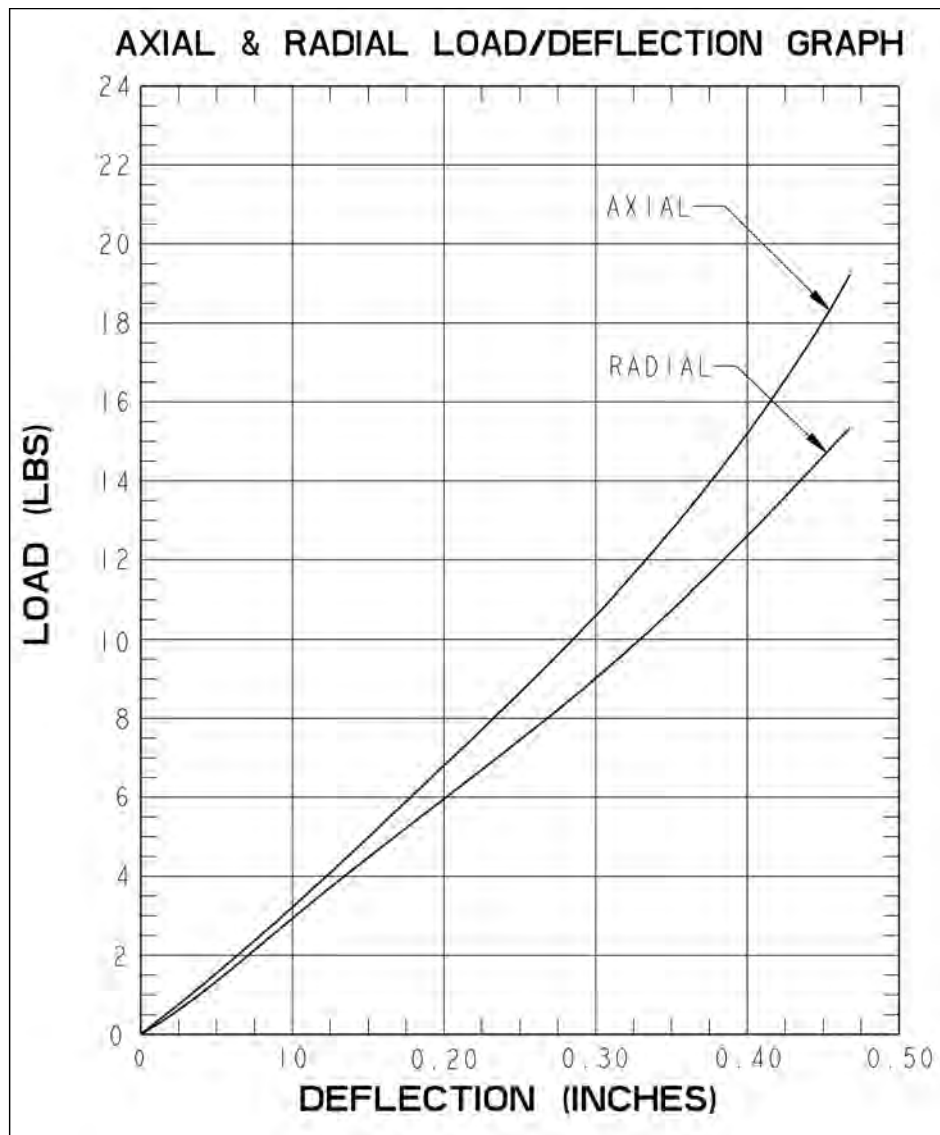

I

FRICTION STYLE MOUNT SERIES



Friction Style Mount Series

1772/1773

Friction damped mounts for vibration isolation and shock attenuation
of aircraft and helicopter application



Applications

- Aircraft avionics and equipment
- Naval electronics
- Sensitive electronic applications that require medical or NBC wash down
- Helicopter electronics

Load Range

- 1772 = 7 load ratings from .25-10 lbs. per mount
- 1773 = 7 load ratings from 2.0-40 lbs. per mount

Attributes

- Fail-safe design
- Friction damped stainless spring
- Axial to radial stiffness ratio 4:1
- Rugged construction

Specifications

- Natural Frequency — 7-10 Hertz
- Transmissibility at resonance — 2.5:1 max.
- Resilient Element — friction damped stainless steel spring
- Standard materials — clear anodized 6061-T6 aluminum
- Isolator weight — 1772 = 1.63 oz. / 1773 = 3.56 oz.

Environmental Data

- Operating temperature ranges of -67°F to +250°F (-55°C to +120°C)
- Meets the requirements of MIL-STD-810F
- Meets the requirements of MIL-C-172C

J

Friction Style Mount Series: 1772

Dimension and Performance Characteristics

Part #	Static Load Range lbs	Dimension "H" Minimum Compressed	Dimension "H" Approx. Under Min. Load	Dimension "H" Maximum Extended	Part #	Static Load Range lbs	Dimension "H" Minimum Compressed	Dimension "H" Approx. Under Min. Load	Dimension "H" Maximum Extended	Part #	Static Load Range lbs	Dimension "H" Minimum Compressed	Dimension "H" Approx. Under Min. Load	Dimension "H" Maximum Extended
1772-AA-5	0.25-0.5	.98	1.40	1.55	1772-BA-5	0.25-0.5	1.13	1.56	1.70	1772-BAM-5	0.25-0.5	1.13	1.56	1.70
1772-AA-1	0.5-1.0	.98	1.40	1.55	1772-BA-1	0.5-1.0	1.13	1.56	1.70	1772-BAM-1	0.5-1.0	1.13	1.56	1.70
1772-AA-2	1.0-2.0	.98	1.40	1.55	1772-BA-2	1.0-2.0	1.13	1.56	1.70	1772-BAM-2	1.0-2.0	1.13	1.56	1.70
1772-AA-3	1.5-3.0	.98	1.40	1.55	1772-BA-3	1.5-3.0	1.13	1.56	1.70	1772-BAM-3	1.5-3.0	1.13	1.56	1.70
1772-AA-4	2.0-4.0	.98	1.40	1.55	1772-BA-4	2.0-4.0	1.13	1.56	1.70	1772-BAM-4	2.0-4.0	1.13	1.56	1.70
1772-AA-6	4.0-6.0	.98	1.40	1.55	1772-BA-6	4.0-6.0	1.13	1.56	1.70	1772-BAM-6	4.0-6.0	1.13	1.56	1.70
1772-AA-10	5.0-10.0	.98	1.40	1.55	1772-BA-10	5.0-10.0	1.13	1.56	1.70	1772-BAM-10	5.0-10.0	1.13	1.56	1.70

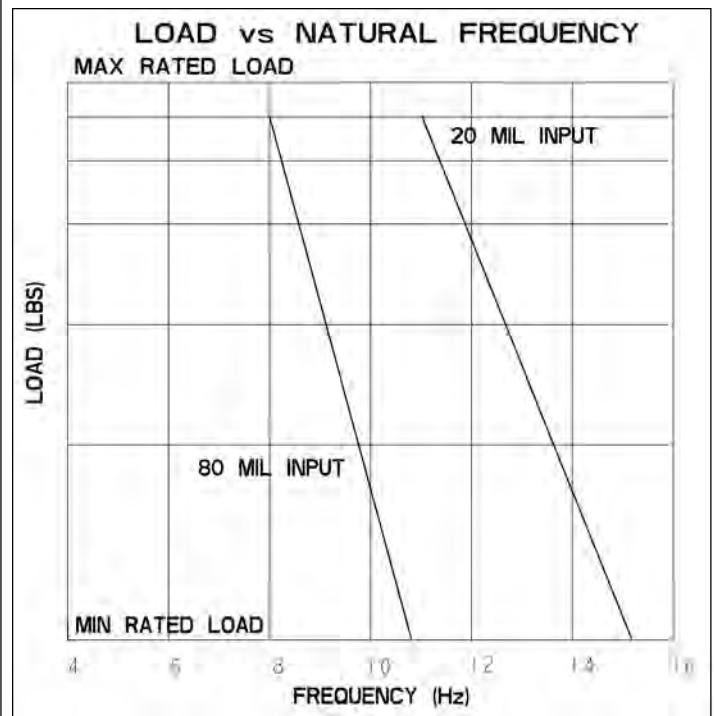
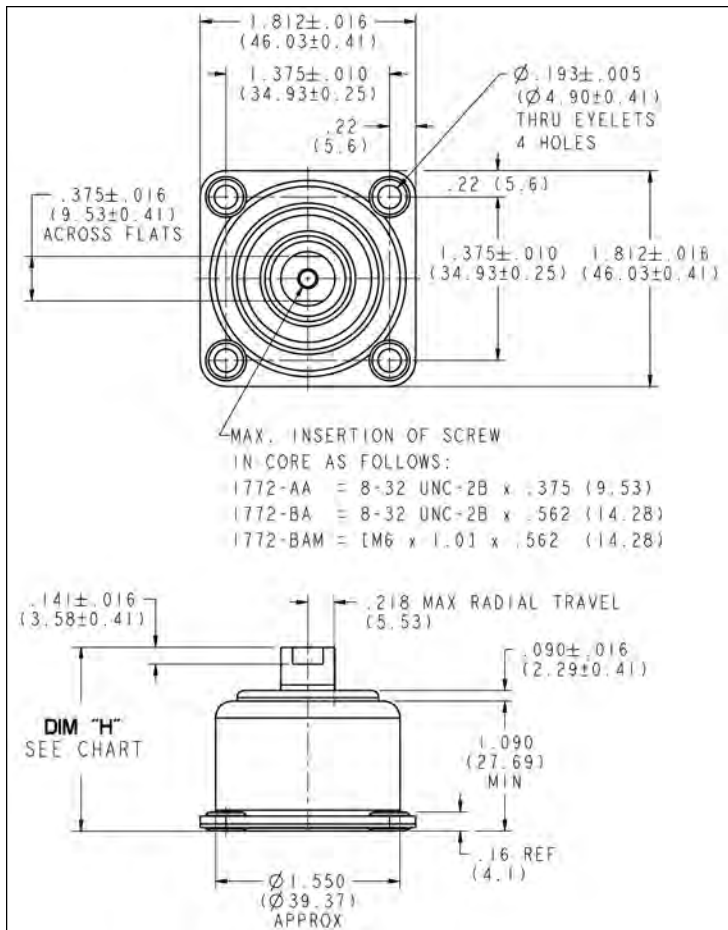

Friction Style Mount Series: 1773

Dimension and Performance Characteristics

Part #	Static Load Range lbs.	Dimension "H" Minimum Compressed	Dimension "H" Approx. Under Min. Load	Dimension "H" Maximum Extended	Part #	Static Load Range lbs.	Dimension "H" Minimum Compressed	Dimension "H" Approx. Under Min. Load	Dimension "H" Maximum Extended	Part #	Static Load Range lbs.	Dimension "H" Minimum Compressed	Dimension "H" Approx. Under Min. Load	Dimension "H" Maximum Extended
1773-AA-04	2.0-4.0	.98	1.41	1.54	1773-BA-04	2.0-4.0	1.14	1.57	1.70	1773-BAM-04	2.0-4.0	1.14	1.57	1.70
1773-AA-06	3.0-6.0	.98	1.41	1.54	1773-BA-06	3.0-6.0	1.14	1.57	1.70	1773-BAM-06	3.0-6.0	1.14	1.57	1.70
1773-AA-10	5.0-10.0	.98	1.41	1.54	1773-BA-10	5.0-10.0	1.14	1.57	1.70	1773-BAM-10	5.0-10.0	1.14	1.57	1.70
1773-AA-15	9.0-15.0	.98	1.41	1.54	1773-BA-15	9.0-15.0	1.14	1.57	1.70	1773-BAM-15	9.0-15.0	1.14	1.57	1.70
1773-AA-20	14.0-20.0	.98	1.41	1.54	1773-BA-20	14.0-20.0	1.14	1.57	1.70	1773-BAM-20	14.0-20.0	1.14	1.57	1.70
1773-AA-30	18.0-30.0	.98	1.41	1.54	1773-BA-30	18.0-30.0	1.14	1.57	1.70	1773-BAM-30	18.0-30.0	1.14	1.57	1.70
1773-AA-40	25.0-40.0	.98	1.41	1.54	1773-BA-40	25.0-40.0	1.14	1.57	1.70	1773-BAM-40	25.0-40.0	1.14	1.57	1.70

J

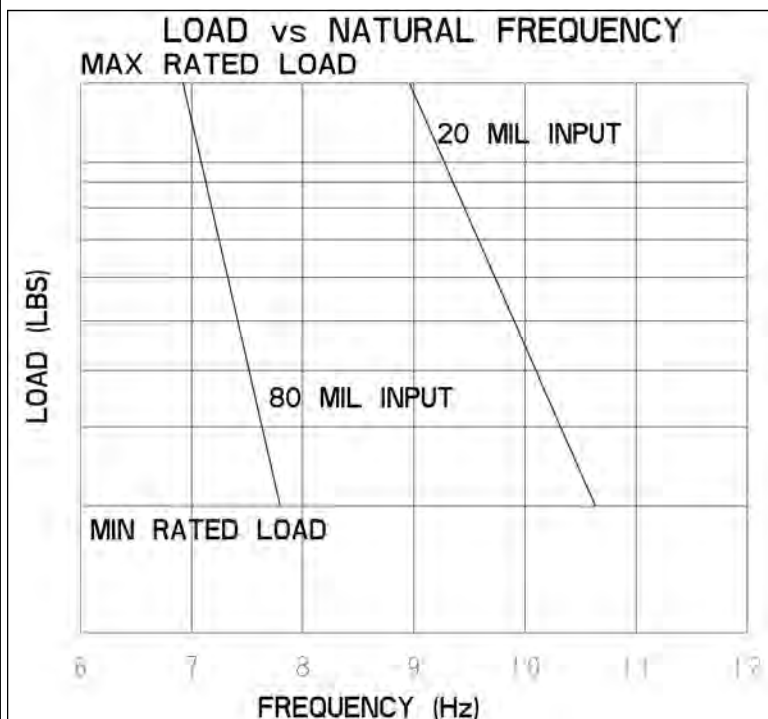
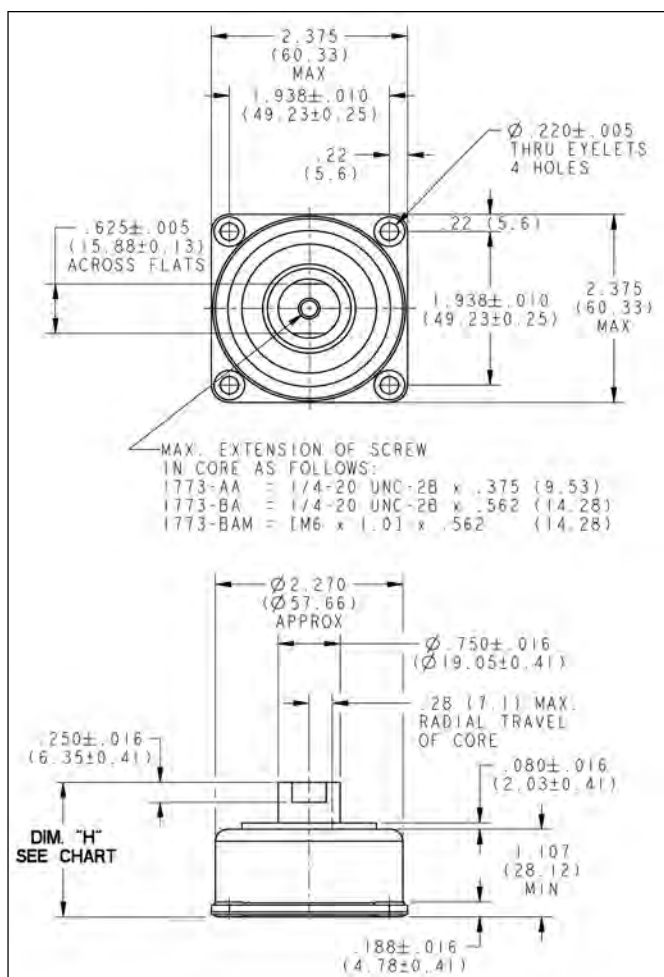

Friction Style Mount Series

1900/1901/1902

Friction damped mounts for vibration isolation and shock attenuation of aircraft and helicopter application



Attributes

- Fail-safe design
- Friction damped stainless spring
- Axial to radial stiffness ratio 4:1
- Rugged construction

Applications

- Aircraft avionics and equipment
- Naval electronics
- Sensitive electronic applications that require medical or NBC wash down
- Helicopter electronics

Load Range

- 1900 = 7 load ratings from .35-4 lbs. per mount
- 1901 = 7 load ratings from .25-10 lbs. per mount
- 1902 = 7 load ratings from 2.0-40 lbs. per mount

Specifications

- Natural Frequency — 7-10 Hertz
- Transmissibility at resonance — 2.5:1 max.
- Resilient Element — friction damped stainless steel spring
- Standard materials — clear anodized 6061-T6 aluminum
- Isolator weight — 1900 = .03 lbs. 1901 = .10 lbs. 1902 = .23 lbs.

Environmental Data

- Operating temperature ranges of -67°F to +250°F (-55°C to +120°C)
- Meets the requirements of MIL-C-172C

Friction Style Mount Series: 1900

Dimension and Performance Characteristics

Part #	Static Load Range (lbs.)	Dimension "H" Minimum Compressed	Dimension "H" Approx. Under Min. Load	Dimension "H" Maximum Extended
1900-BA-0.5	0.38-0.54	.72	1.00	1.18
1900-BA-0.7	0.44-0.75	.72	1.00	1.18
1900-BA-1.0	0.56-1.00	.72	1.00	1.18
1900-BA-1.3	0.88-1.30	.72	1.00	1.18
1900-BA-2.0	1.20-2.00	.72	1.00	1.18
1900-BA-3.0	1.70-3.00	.72	1.00	1.18
1900-BA-4.0	2.50-4.00	.72	1.00	1.18

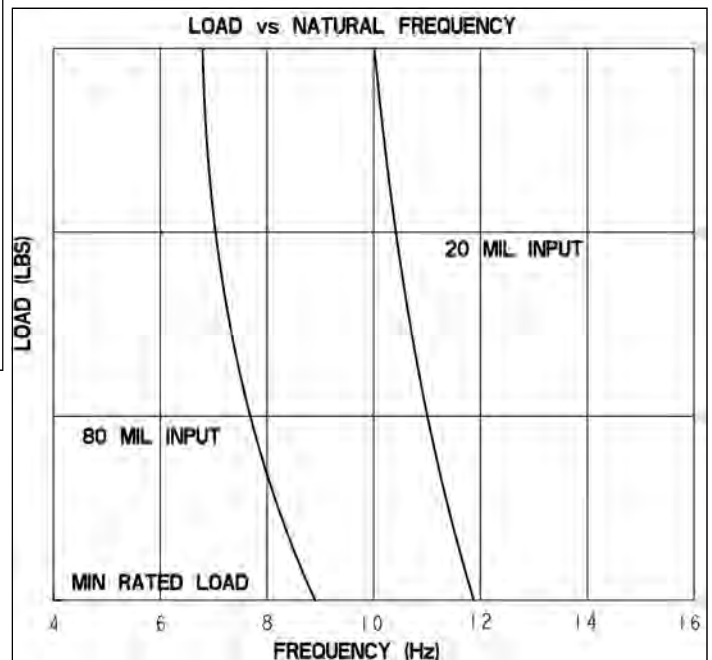
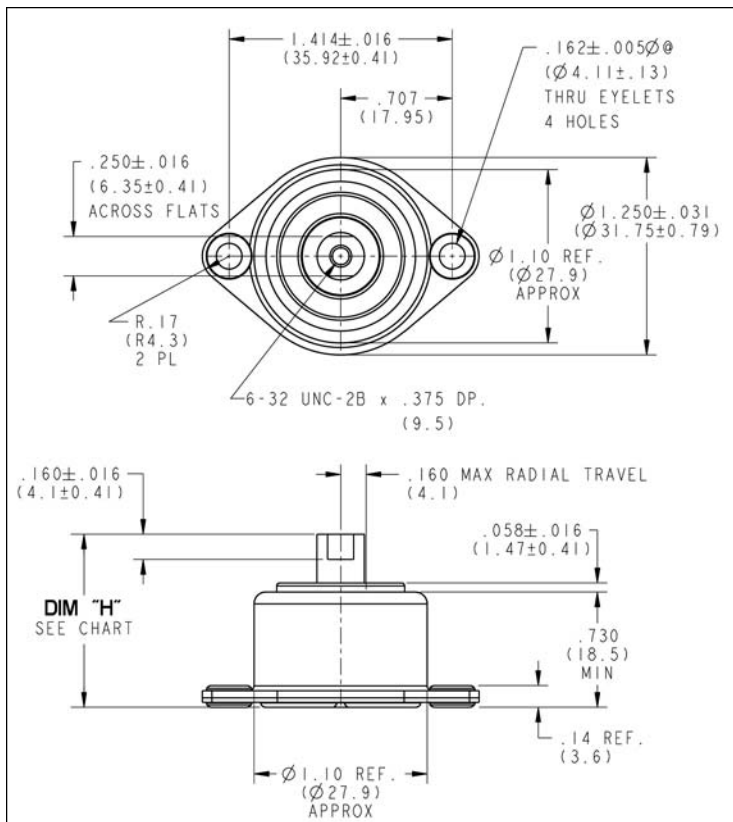

J

Friction Style Mount Series: 1901

Dimension and Performance Characteristics

Part #	Static Load Range (lbs.)	Dimension "H" Minimum Compressed	Dimension "H" Approx. Under Min. Load	Dimension "H" Maximum Extended
1901-AA-.5	.25-.50	.98	1.40	1.63
1901-AA-1	.50-1.00	.98	1.40	1.63
1901-AA-2	1.00-2.00	.98	1.40	1.63
1901-AA-3	1.50-3.00	.98	1.40	1.63
1901-AA-4	2.00-4.00	.98	1.40	1.63
1901-AA-5	2.50-5.00	.98	1.40	1.63
1901-AA-10	5.00-10.00	.98	1.40	1.63
1901-BA-.5	.25-.50	1.13	1.56	1.79
1901-BA-1	.50-1.00	1.13	1.56	1.79
1901-BA-2	1.00-2.00	1.13	1.56	1.79
1901-BA-3	1.50-3.00	1.13	1.56	1.79
1901-BA-4	2.00-4.00	1.13	1.56	1.79
1901-BA-5	2.50-5.00	1.13	1.56	1.79
1901-BA-10	5.00-10.00	1.13	1.56	1.79
1901-BAM-.5	.25-.50	1.13	1.56	1.79
1901-BAM-1	.50-1.00	1.13	1.56	1.79
1901-BAM-2	1.00-2.00	1.13	1.56	1.79
1901-BAM-3	1.50-3.00	1.13	1.56	1.79
1901-BAM-4	2.00-4.00	1.13	1.56	1.79
1901-BAM-5	2.50-5.00	1.13	1.56	1.79
1901-BAM-10	5.00-10.00	1.13	1.56	1.79

Friction Style Mount Series: 1901

Dimension and Performance Characteristics

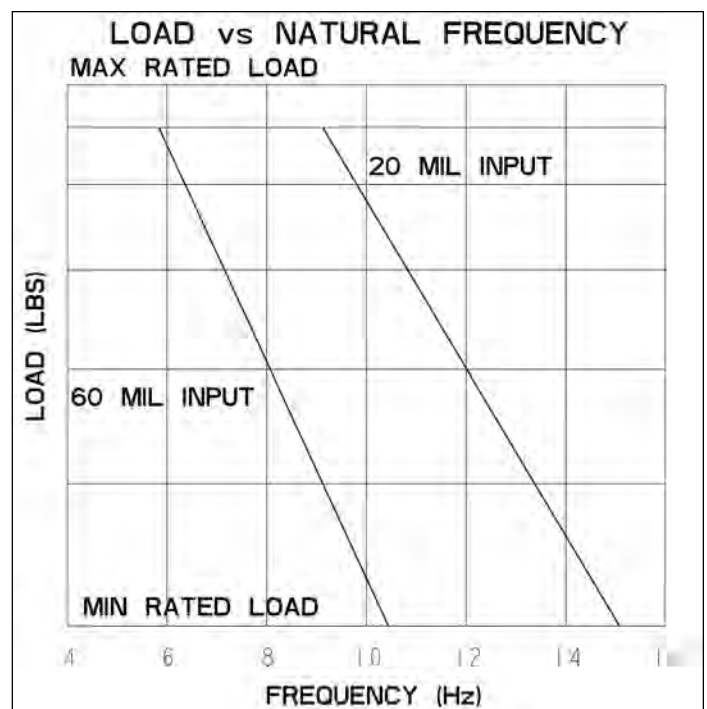
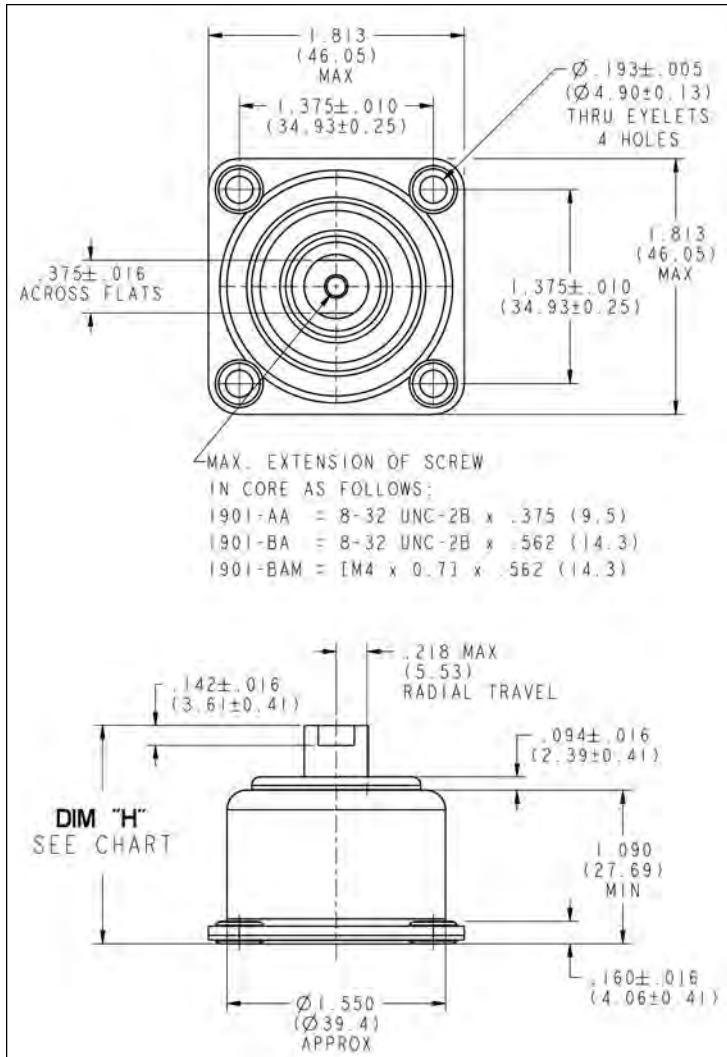

J

Friction Style Mount Series: 1902

Dimension and Performance Characteristics

Part #	Static Load Range (lbs.)	Dimension "H" Minimum Compressed	Dimension "H" Approx. Under Min. Load	Dimension "H" Maximum Extended
1902-AA-04	2.0-4.5	.98	1.41	1.54
1902-AA-06	3.0-6.0	.98	1.41	1.54
1902-AA-10	4.5-10.0	.98	1.41	1.54
1902-AA-12	6.25-12.5	.98	1.41	1.54
1902-AA-16	9.0-16.0	.98	1.41	1.54
1902-AA-20	10.0-20.0	.98	1.41	1.54
1902-AA-40	20.0-40.0	.98	1.41	1.54
1902-BA-04	2.0-4.5	1.14	1.57	1.70
1902-BA-06	3.0-6.0	1.14	1.57	1.70
1902-BA-10	4.5-10.0	1.14	1.57	1.70
1902-BA-12	6.25-12.5	1.14	1.57	1.70
1902-BA-16	9.0-16.0	1.14	1.57	1.70
1902-BA-20	10.0-20.0	1.14	1.57	1.70
1902-BA-40	20.0-40.0	1.14	1.57	1.70
1902-BAM-04	2.0-4.5	1.14	1.57	1.70
1902-BAM-06	3.0-6.0	1.14	1.57	1.70
1902-BAM-10	4.5-10.0	1.14	1.57	1.70
1902-BAM-12	6.25-12.5	1.14	1.57	1.70
1902-BAM-16	9.0-16.0	1.14	1.57	1.70
1902-BAM-20	10.0-20.0	1.14	1.57	1.70
1902-BAM-40	20.0-40.0	1.14	1.57	1.70

Friction Style Mount Series: 1902

Dimension and Performance Characteristics

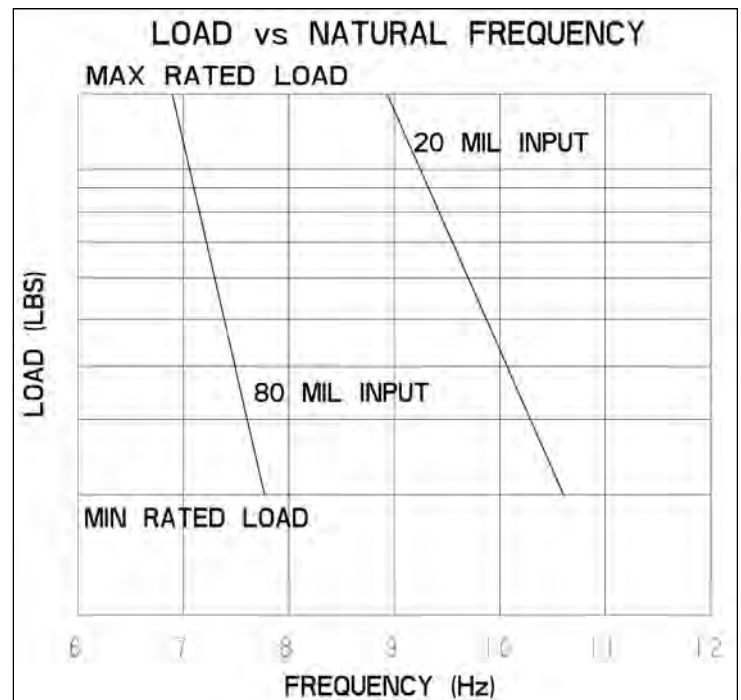
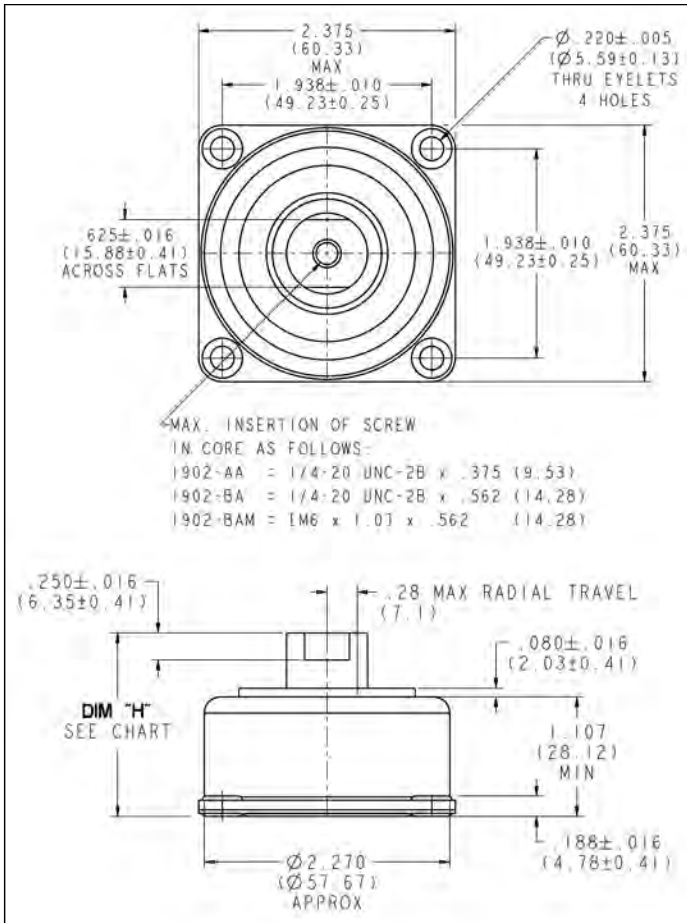

J

HIGH DEFLECTION MOUNT SERIES

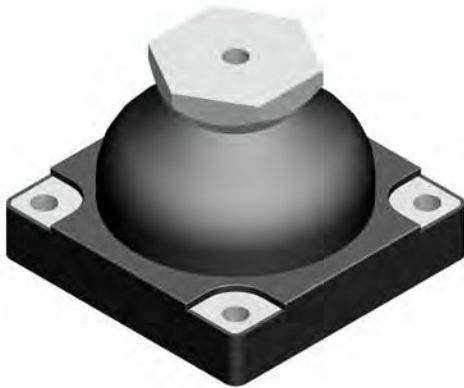
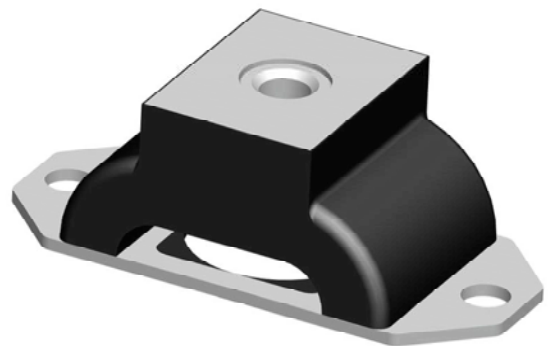

Low Profile Buckling Mount Series 1774/1775

Low profile, buckling design vibration isolators for industrial equipment

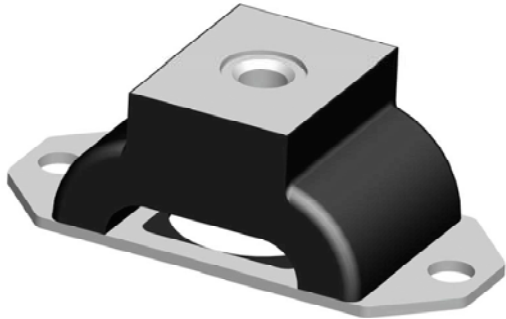

Attributes

- Vibration attenuation below 15 Hz
- Effectively isolate disturbing frequencies as low as 900 rpm (15 Hz)
- Neoprene and zinc plated steel construction
- Cold-rolled steel construction
- Stainless steel version available for marine applications
- All attitude design
- Axial to radial stiffness ratio 4:1

Applications

- Marine applications
- Industrial applications
- HVAC
- Power generation
- Fans and blowers
- Pumps

Load Range

- 1774 = load ratings to 130 lbs.
- 1775 = load ratings to 260 lbs.

K

Specifications

- Natural Frequency — 8 Hertz
- Transmissibility at resonance — 10:1
- Resilient Element — Neoprene
- Standard materials — zinc plated cold rolled steel
- Weight—1774-1 through 3 = 7 oz. / 1775-1 and 2 = 16 oz.

Elastomeric Data

- Neoprene elastomer has an operating temperature range of -40°F to 200°F (-40°C to +93°C) and is resistant to oils, most solvents and ozone
- Stainless steel version is corrosion resistant for marine applications and are available upon request

Low Profile Buckling Mount Series: 1774

Dimension and Performance Characteristics

Part #	Maximum Static Load / Isolator (lbs.)	Durometer
1774-1	60	40
1774-2	100	50
1774-3	130	60
1774-1SS	60	40
1774-2SS	100	50
1774-3SS	130	60

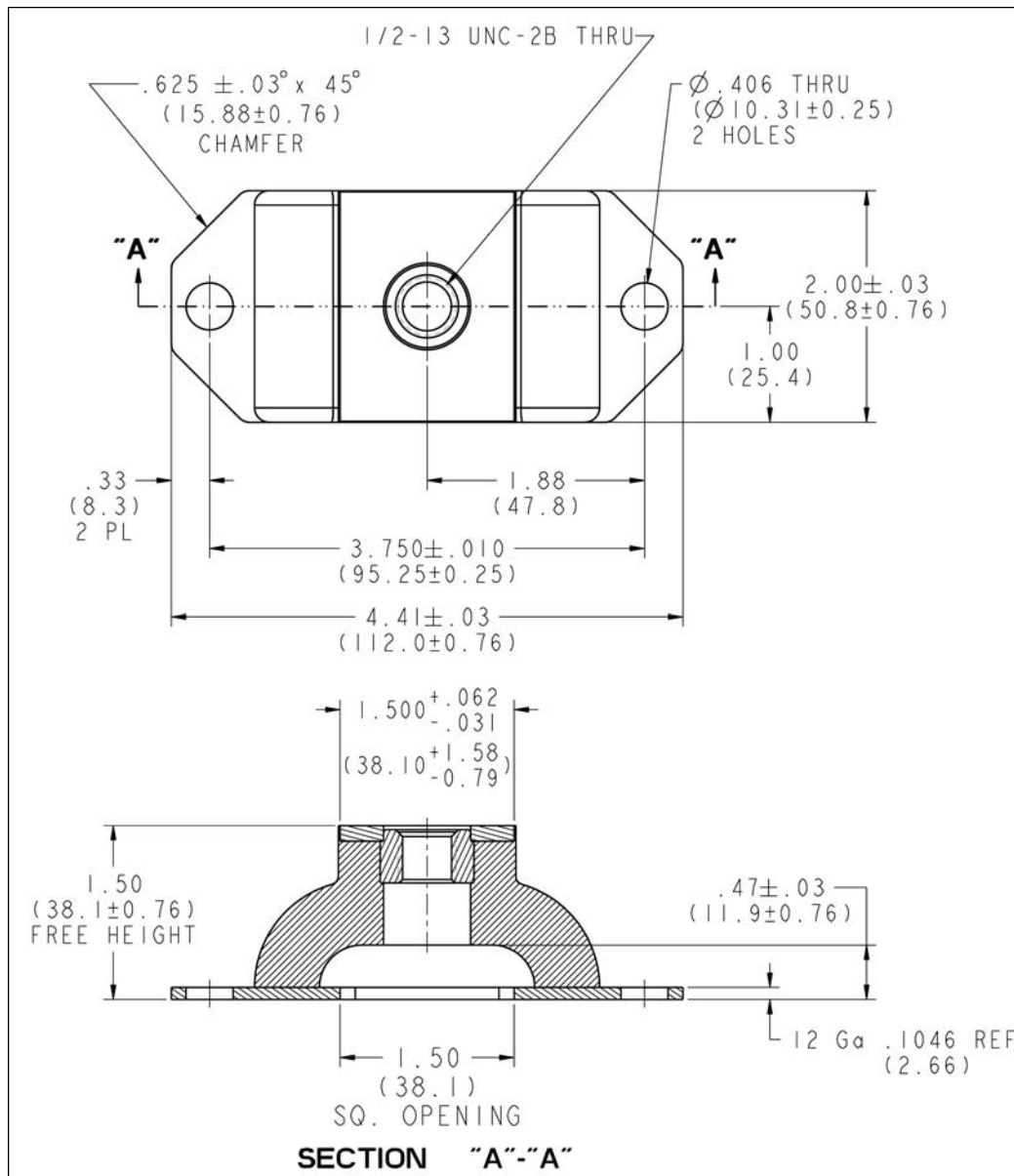

Low Profile Buckling Mount Series: 1774

Dimension and Performance Characteristics

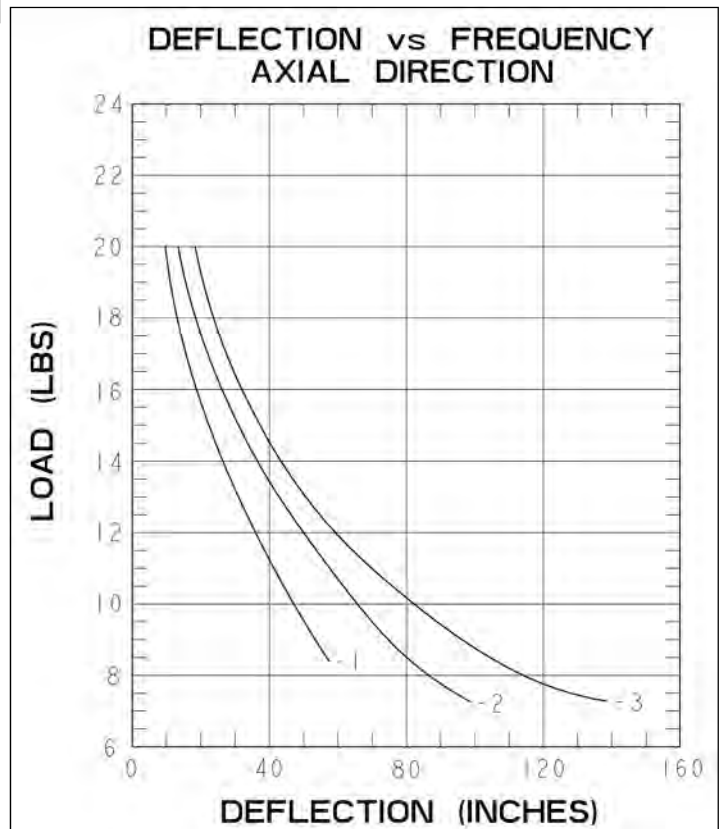
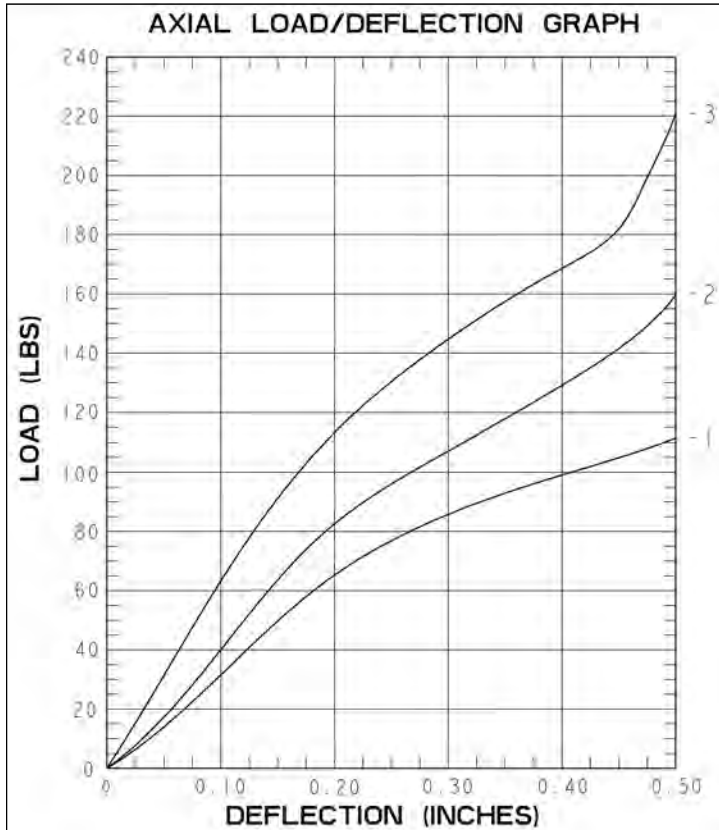

K

Low Profile Buckling Mount Series: 1775

Dimension and Performance Characteristics

Part #	Maximum Static Load / Isolator (lbs.)	Durometer
1775-1	200	40
1775-2	260	50
1775-1SS	200	40
1775-2SS	260	50

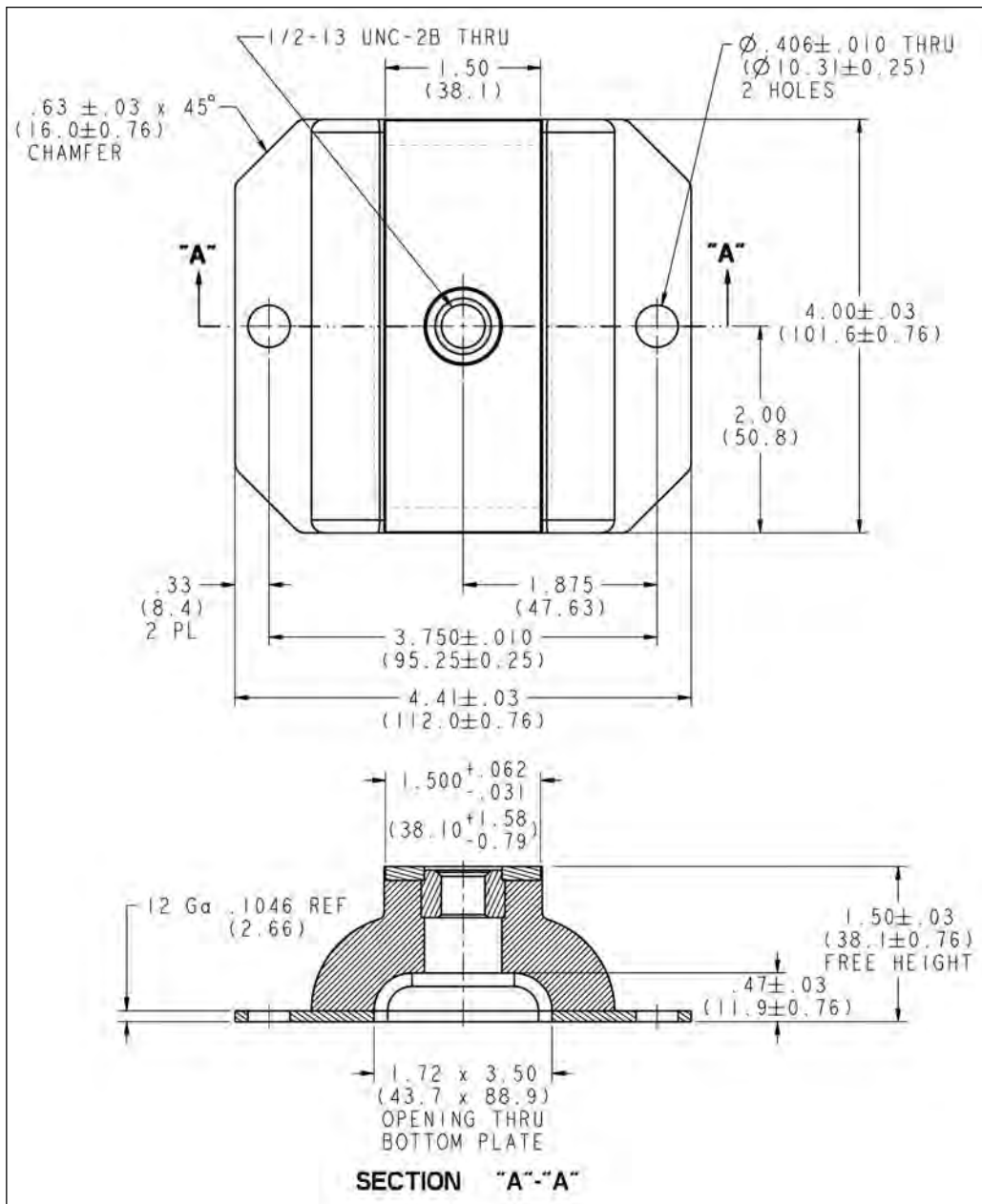

Low Profile Buckling Mount Series: 1775

Dimension and Performance Characteristics

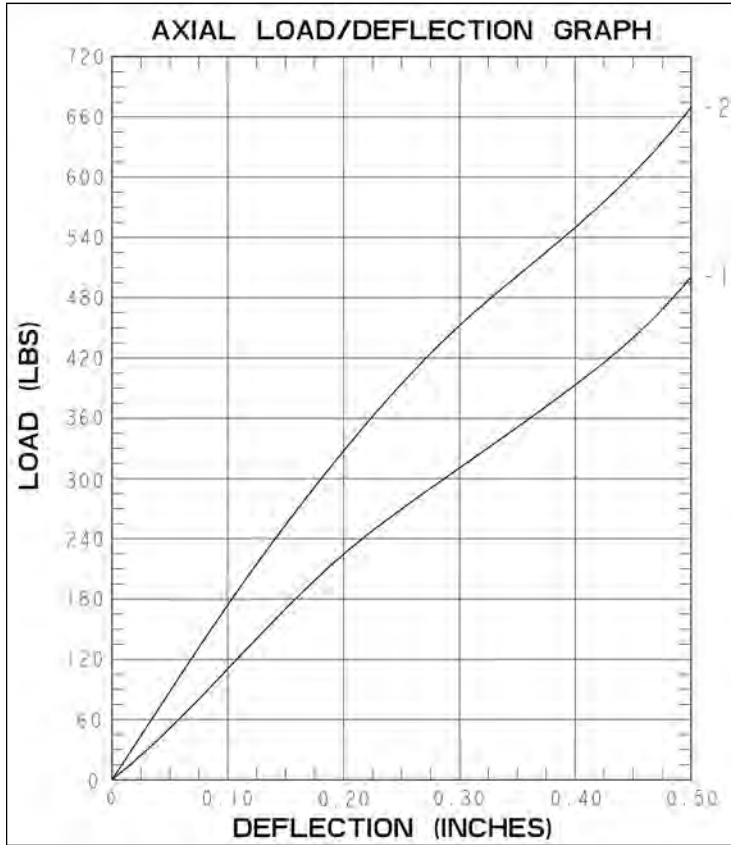

K

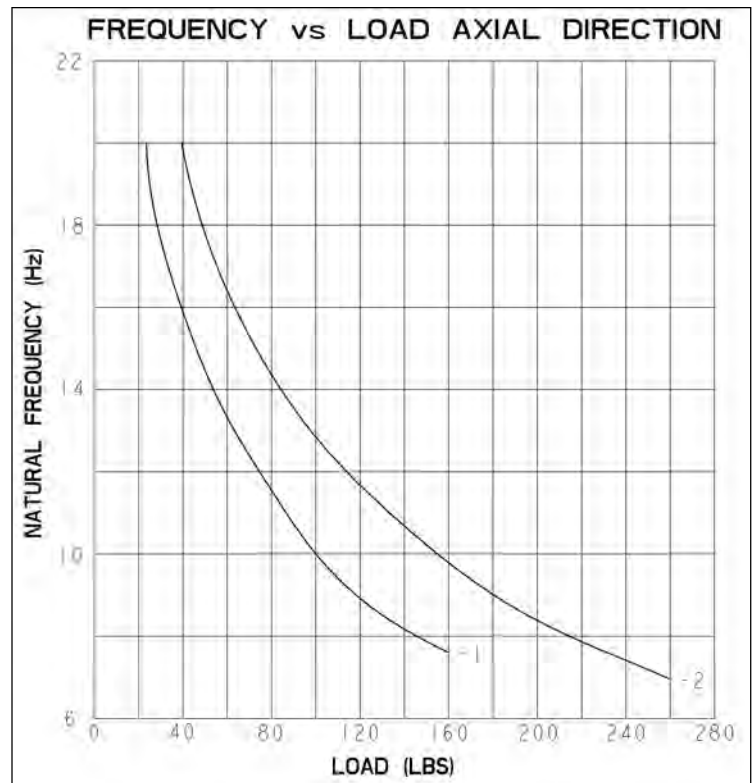

High Deflection Dome Mounts 1824

A low profile, high deflection mount for protection
from severe vibration and shock inputs



Attributes

- High deflection capability for shock load
- Axial to radial stiffness ratio 2.3:1
- Compact, low profile design
- Easy to install
- High Damped Silicone or Neoprene
- Aluminum construction
- Can be used in tandem for higher deflection capability
- Can be custom tailored to specific applications

Applications

- Military computer applications
- Transit cases
- Avionics and racking
- Shipboard electronics
- Random vibration environments

Shock and Vibe

- Attenuates a 15g, 11 millisecond half-sine shock to 6 g's
- Survives a 30g, 11 millisecond half-sine crash safety shock to 15 g's

Load Range

- 1824-1S = load ratings to 10 lbs.
- 1824-2S = load ratings to 18 lbs.
- 1824-3S = load ratings to 25 lbs.
- 1824-1N = load ratings to 12 lbs.
- 1824-2N = load ratings to 20 lbs.
- 1824-3N = load ratings to 30 lbs.

Specifications

- Natural Frequency — 25-35 Hertz
- Transmissibility at resonance — 4.0 max. (Hi-damped Silicone) 10:1 max. (Neoprene)
- Resilient Element — Hi-Damped Silicone or Neoprene
- Standard materials — Aluminum (Grounding Strap Beryllium Copper)
- Weight = 6.5 oz.

Elastomeric Data

- Hi-Damp Silicone operating temperature range of -67°F to +300°F (-55°C to +150°C) and is resistant to fungus and ozone
- Neoprene operating temperature range of -40°F to 200°F (-40°C to +93°C) and is oil and ozone resistant

High Deflection Dome Mounts: 1824

Dimension and Performance Characteristics

Part #	Maximum Axial Compression	Load (lbs.) Radial	Axial Natural Frequency (hz)	Standard Material	Standard Elastomer	Transmissibility at Resonance
1824-1S	10	10	23	6061-T6 Aluminum	Hi-Damp Silicone	4:1
1824-2S	18	18	22	6061-T6 Aluminum	Hi-Damp Silicone	4:1
1824-3S	25	25	25	6061-T6 Aluminum	Hi-Damp Silicone	4:1
1824-1N	12	12	30	6061-T6 Aluminum	Neoprene Rubber	10:1
1824-2N	20	20	32	6061-T6 Aluminum	Neoprene Rubber	10:1
1824-3N	30	30	34	6061-T6 Aluminum	Neoprene Rubber	10:1

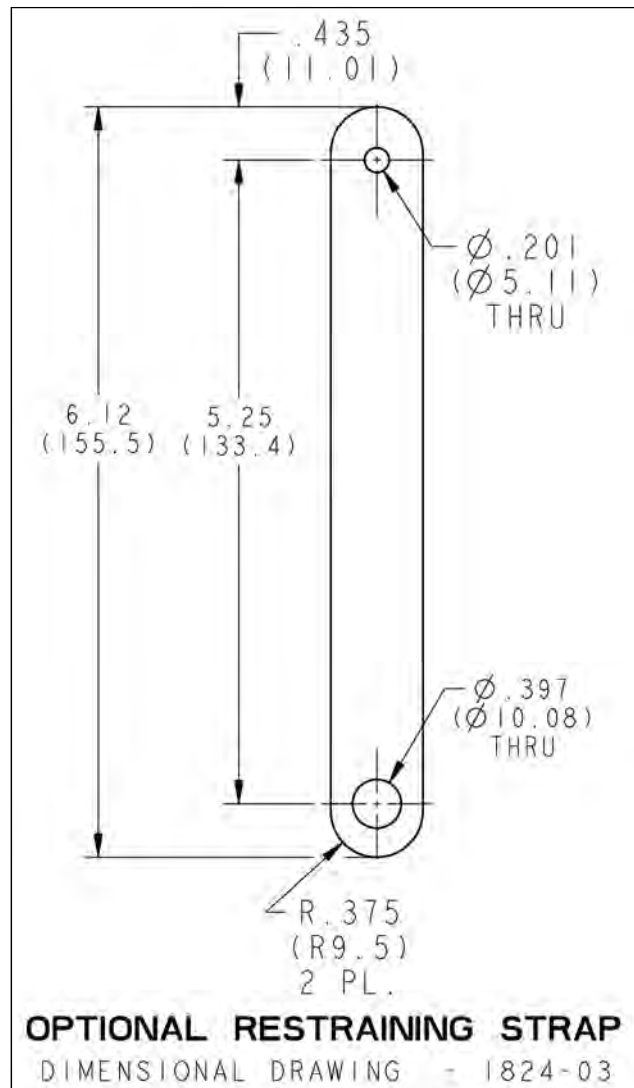
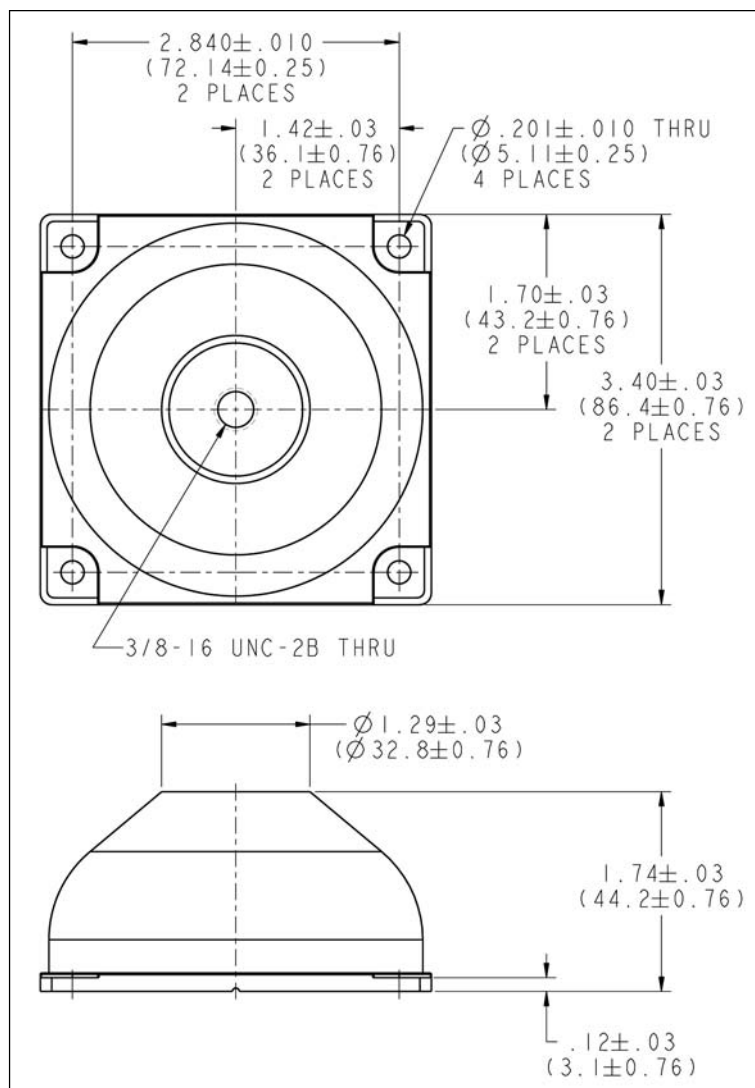

K

High Deflection Dome Mounts: 1824

Dimension and Performance Characteristics

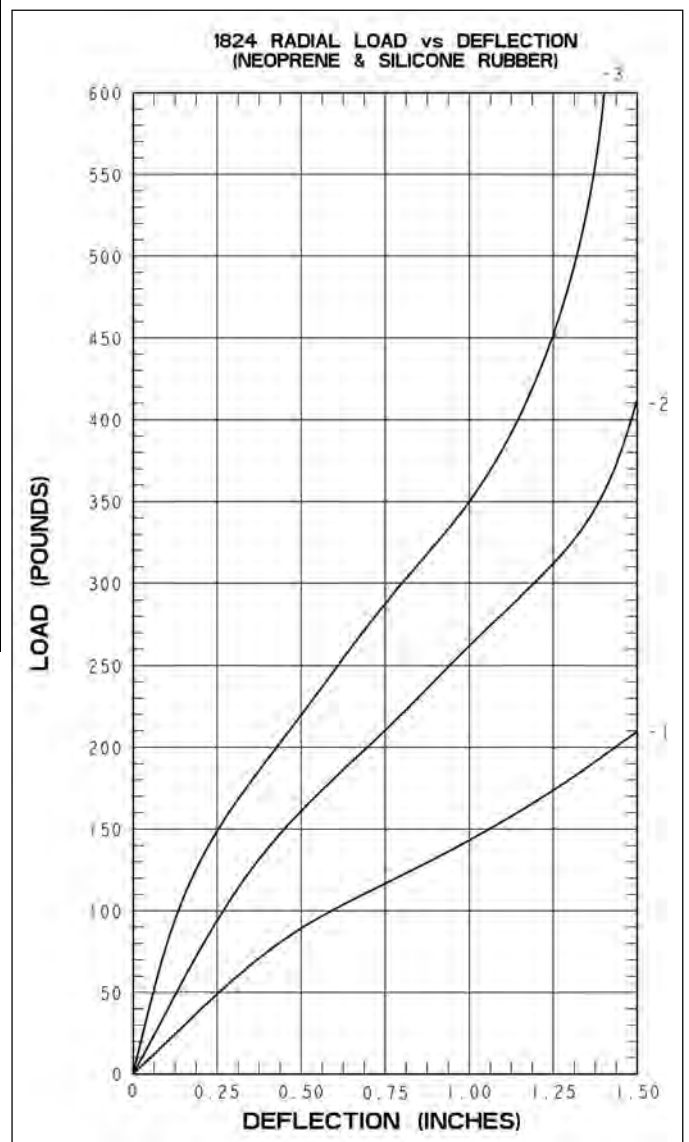
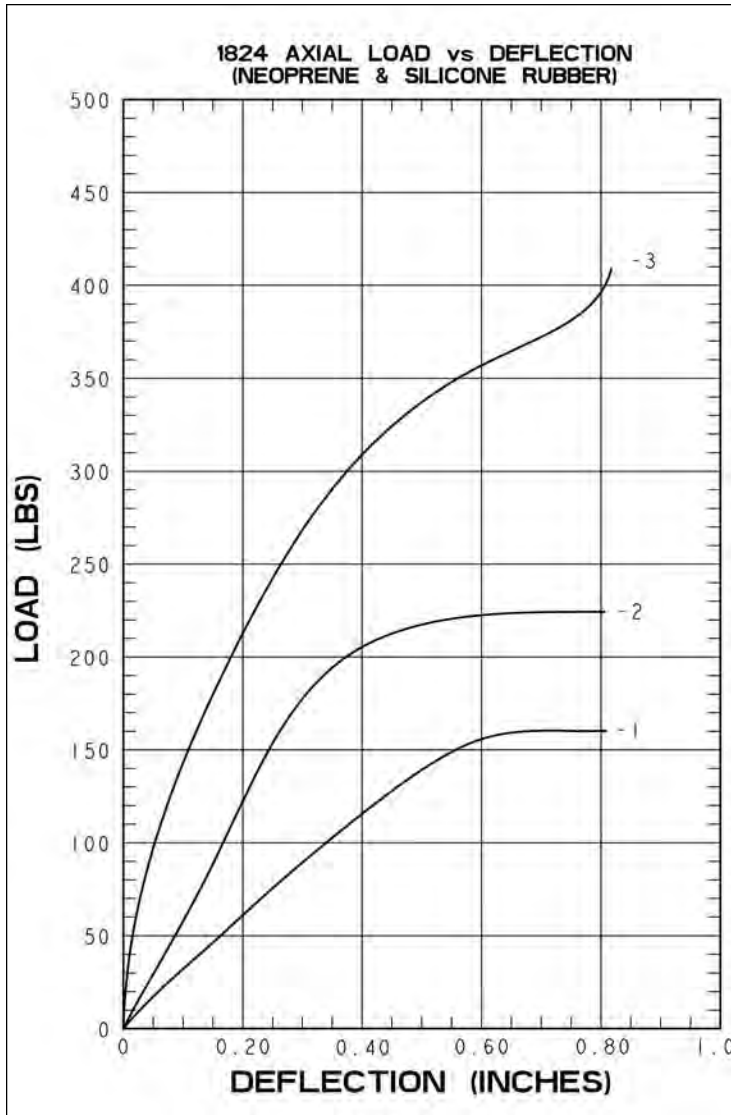

High Deflection Dome Mounts 1829

A low profile, high deflection mount for protection
from severe vibration and shock inputs



Attributes

- High deflection capability for shock load
- Axial to radial stiffness ratio 1:1
- Compact, low profile design
- Easy to install
- High Damped Silicone
- Aluminum construction
- Can be used in tandem for higher deflection capability

Applications

- Military computer applications
- Electronics on aircraft applications
- Avionics and racking
- Random vibration environments

Shock and Vibe

- Attenuates a 15g, 11 millisecond half-sine shock to 6 g's
- Survives a 30g, 11 millisecond half-sine crash safety shock

Load Range

- 1829-1N = load ratings to 7 lbs.
- 1829-2N = load ratings to 10 lbs.
- 1829-3N = load ratings to 15 lbs.
- 1829-1S = load ratings to 7 lbs.
- 1829-2S = load ratings to 10 lbs.
- 1829-3S = load ratings to 15 lbs.

K

Specifications

- Natural Frequency—12-20 Hertz
- Transmissibility at resonance — 4.0 max. (Hi-damped Silicone), 10:1 max. (Neoprene)
- Resilient Element — Hi-Damped Silicone or Neoprene
- Standard materials — Aluminum (Grounding Strap Beryllium Copper)
- Weight = 2.0 oz.

Elastomeric Data

- Hi-Damp Silicone operating temperature range of -67F to +300°F (-55°C to +150°C) and is resistant to fungus and ozone
- Neoprene operating temperature range of -40°F to 200°F (-40°C to +93°C) and is resistant to oil and ozone

High Deflection Dome Mounts: 1829

Dimension and Performance Characteristics

Part #	Maximum Axial Compression	Load (lbs.) Radial	Axial Natural Frequency (HZ)	Standard Material	Standard Elastomer	Transmissibility at Resonance
1829-1N	5-7	5-7	14	6061-T6 Aluminum	Neoprene Rubber	10:1
1829-2N	7-10	7-10	15	6061-T6 Aluminum	Neoprene Rubber	10:1
1829-3N	10-15	10-15	14	6061-T6 Aluminum	Neoprene Rubber	10:1
1829-1S	5-7	5-7	14	6061-T6 Aluminum	Hi-Damp Silicone	4:1
1829-2S	7-10	7-10	14	6061-T6 Aluminum	Hi-Damp Silicone	4:1
1829-3S	10-15	10-15	14	6061-T6 Aluminum	Hi-Damp Silicone	4:1

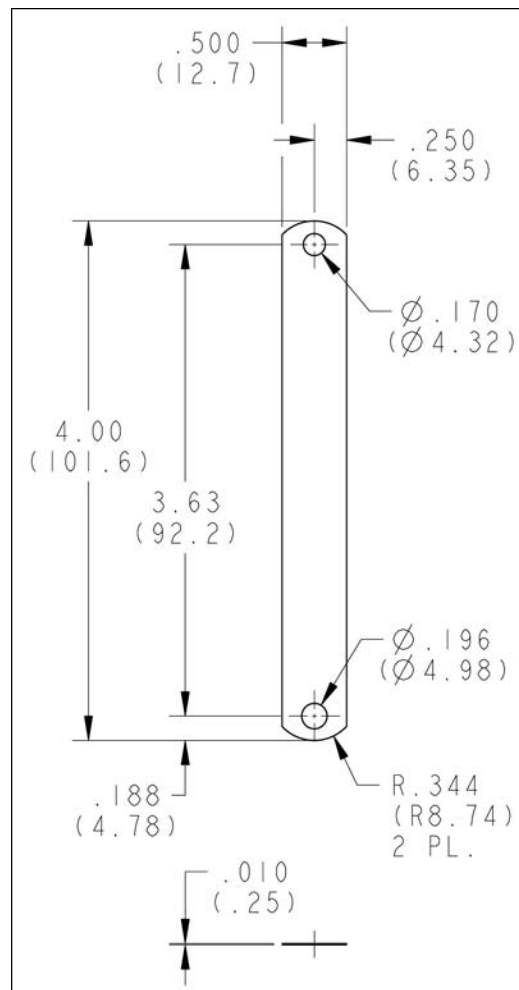
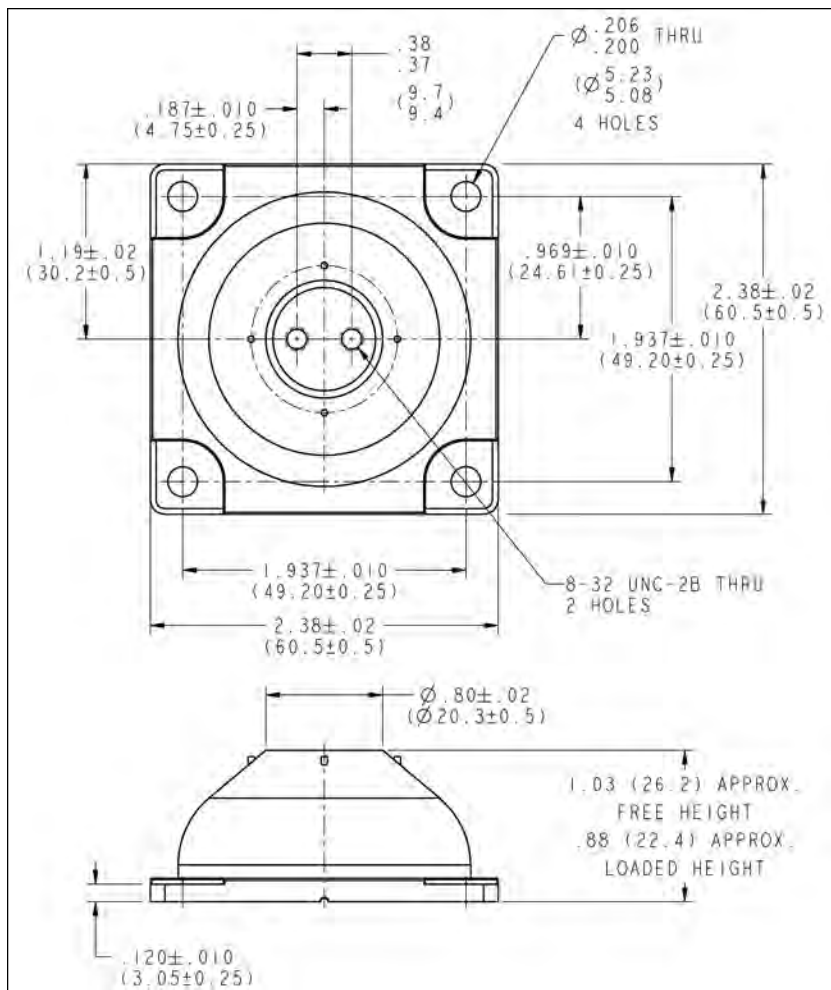

High Deflection Dome Mounts: 1829

Dimension and Performance Characteristics

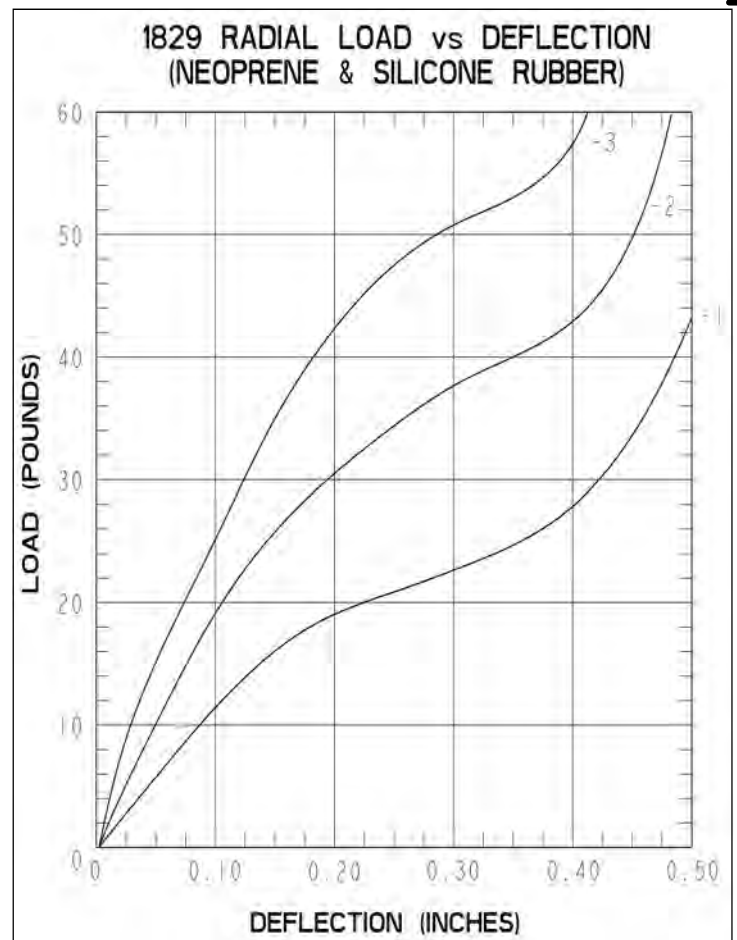
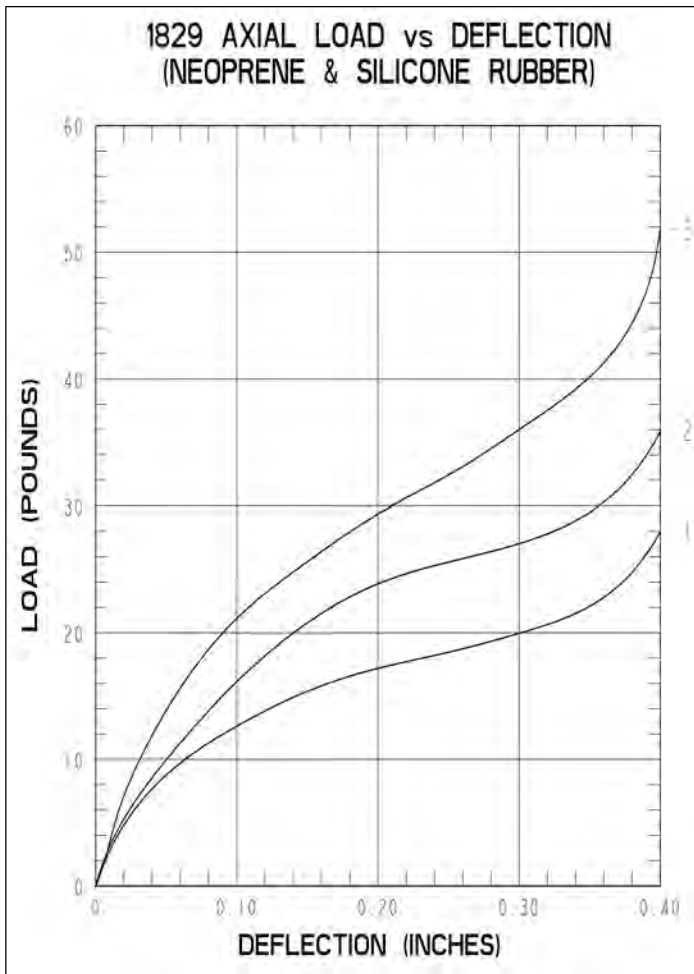

K

1825 Mount Series

Low frequency, highly damped mounts for high level shock and vibration isolation

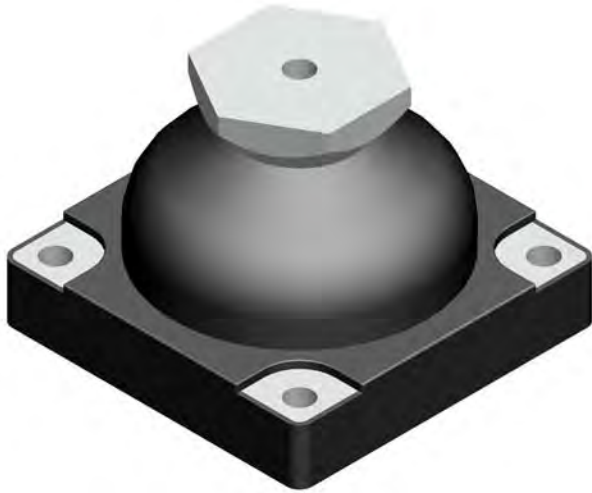

Attributes

- High deflection capability for shock loads
- Axial to radial stiffness is 1:1.4
- Aluminum construction
- High damped silicone
- Easy to install

Applications

- MIL-STD-810C helicopter environments
- High deflection, random vibration environments

Shock and Vibe

- Attenuates a 15g, 11 millisecond half-sine shock to 6 g's
- Survives a 30g, 11 millisecond half-sine crash safety shock

Load Range

- 1825-1 = load ratings from 5-8 lbs.
- 1825-2 = load ratings from 7-13 lbs.
- 1825-3 = load ratings from 13-20 lbs.

Specifications

- Natural Frequency — 10-13 Hertz
- Transmissibility at resonance — 4.0 max.
- Resilient Element — Hi-Damped Silicone
- Standard materials — Aluminum (Grounding Strap Beryllium Copper)
- Weight = 4 oz.

Elastomeric Data

- Hi-Damp Silicone operating temperature range of -67°F to $+300^{\circ}\text{F}$ (-55°C to $+150^{\circ}\text{C}$) and is resistant to fungus and ozone

Mount Series: 1825

Dimension and Performance Characteristics

Part #	Axial Load Range (lbs)	Transmissibility	Axial Natural Frequency (hz)	Free Height	Resilient Materials	Structural Materials	Core Style	Center Hole	Flange Holes
1825-1	5-8	4:1	10-13	1.72	Hi-Damp Silicone	Aluminum	Threaded	1/4-20	.201
1825-2	7-13	4:1	10-13	1.72	Hi-Damp Silicone	Aluminum	Threaded	1/4-20	.201
1825-3	13-20	4:1	10-13	1.72	Hi-Damp Silicone	Aluminum	Threaded	1/4-20	.201

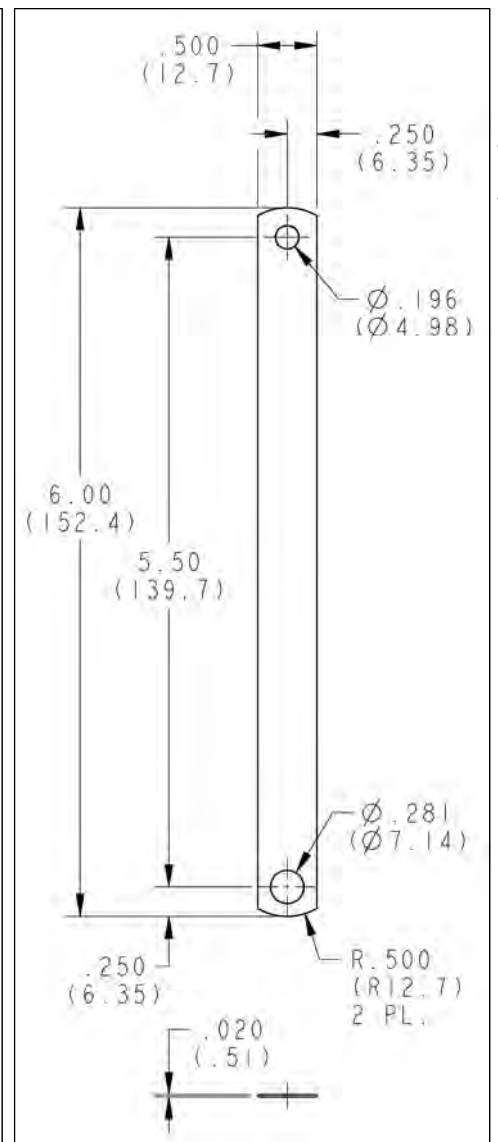
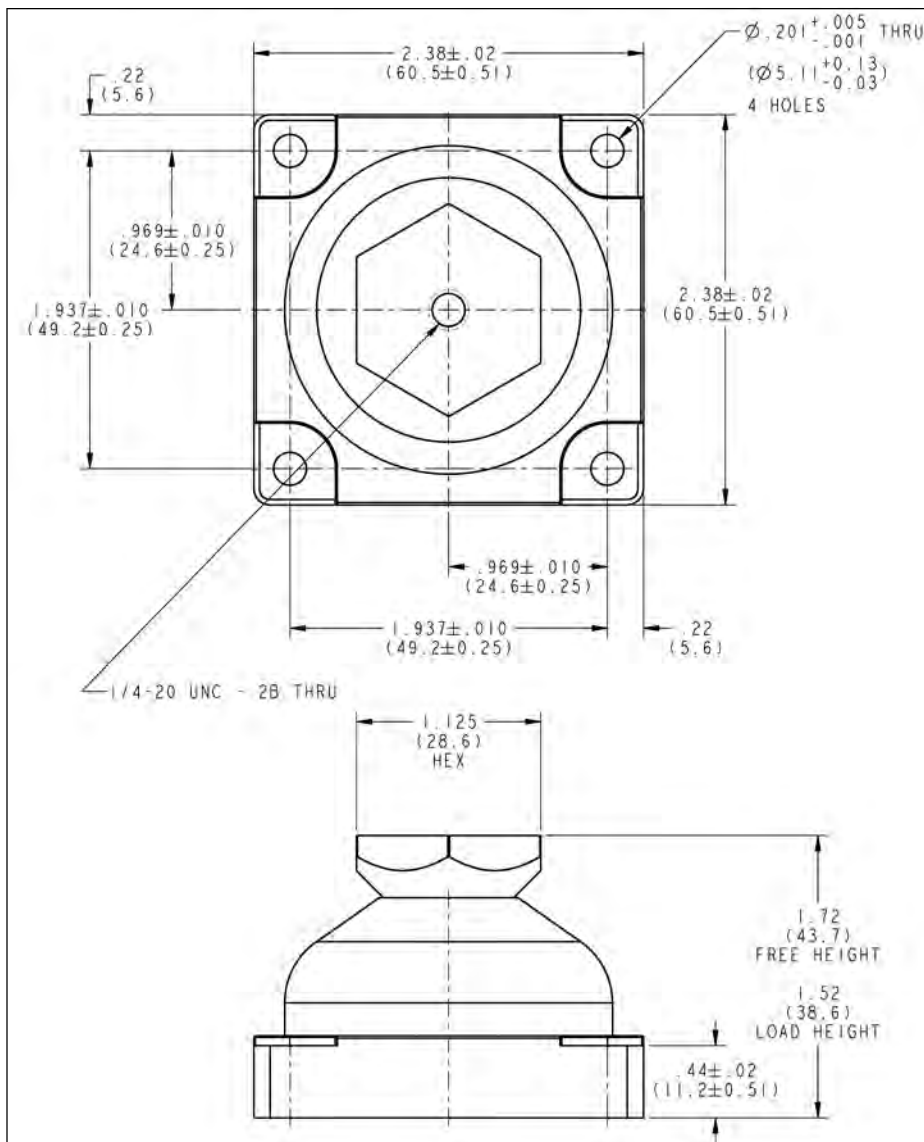

K

Mount Series: 1825

Dimension and Performance Characteristics

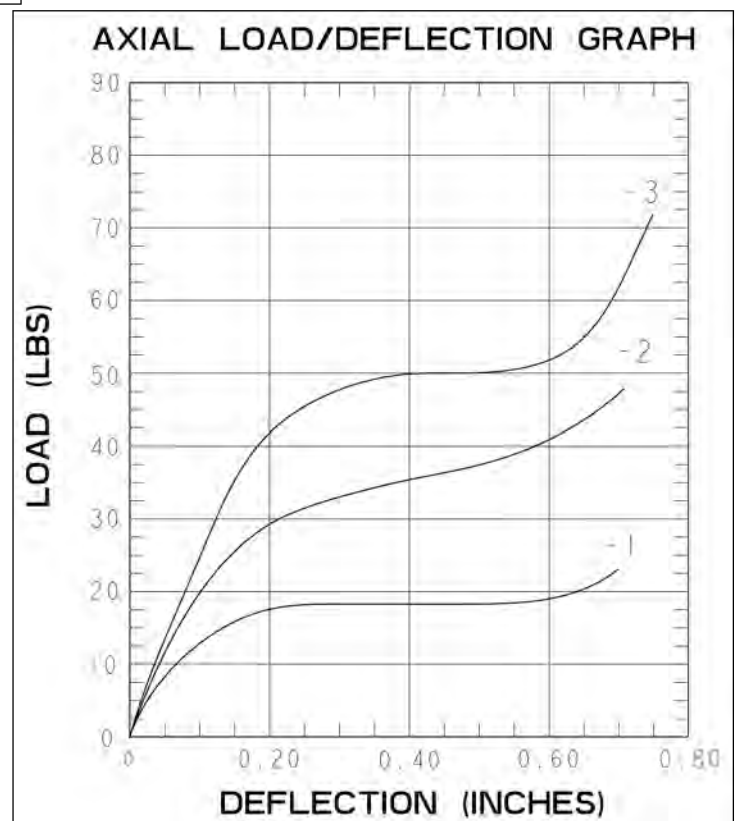
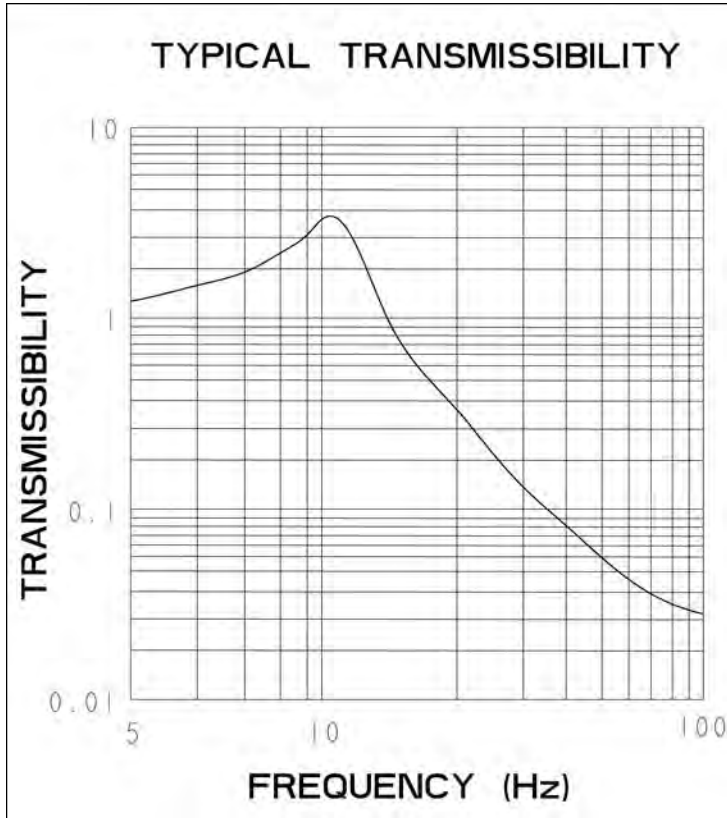

1975 Arch Mount Series

High deflection, buckling design, shock and vibration isolators for sensitive equipment



Applications

- Shipboard equipment
- Transit cases
- Vehicle electronics
- Missile transportation
- Lab equipment

Load Range

- 1975-1 = load ratings to 45 lbs.
- 1975-2 = load ratings to 70 lbs.
- 1975-3 = load ratings to 100 lbs.
- 1975-4 = load ratings to 145 lbs.

K

Attributes

- Steel construction
- Buckling design
- Axial to radial stiffness ratio 2:1
- Designed to carry static loads in the axial direction but can accommodate dynamic inputs in the radial direction
- Attenuates 18" freefall drop input to 12g's

Specifications

- Natural Frequency — 12-20 Hertz
- Transmissibility at resonance — 10:1 max. for Neoprene, 5.1 max. for Polybutadiene
- Resilient Element — Neoprene
- Standard materials — Steel (Grounding Strap Beryllium Copper)
- Weight = 4 lbs.

Elastomeric Data

- Neoprene has an operating temperature range of -40°F to 200°F (-40°C to $+93^{\circ}\text{C}$) and is resistant to fungus and ozone
- Polybutadiene (low temperature) compound has an operating temperature range of -60°F to $+180^{\circ}\text{F}$ (-50°C to 82°C) and resists oil and ozone

Arch Mount Series: 1975

Dimension and Performance Characteristics

Part #		Maximum Axial Load Ratings (lbs.)
Neoprene	Polybutadiene	
1975-1A	1975-5A	45
1975-2A	1975-6A	70
1975-3A	1975-7A	100
1975-4A	1975-8A	145

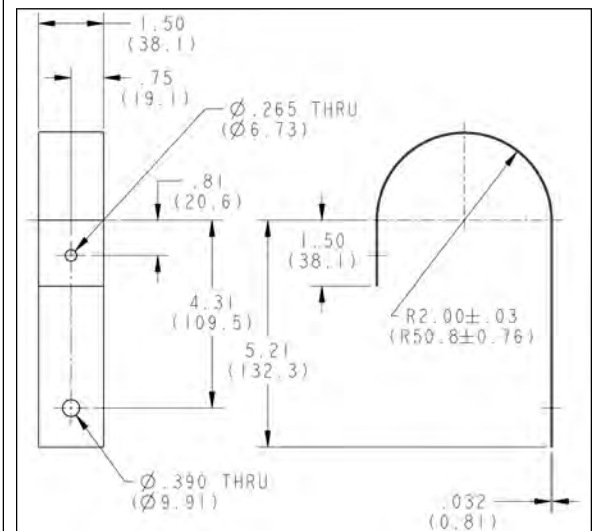
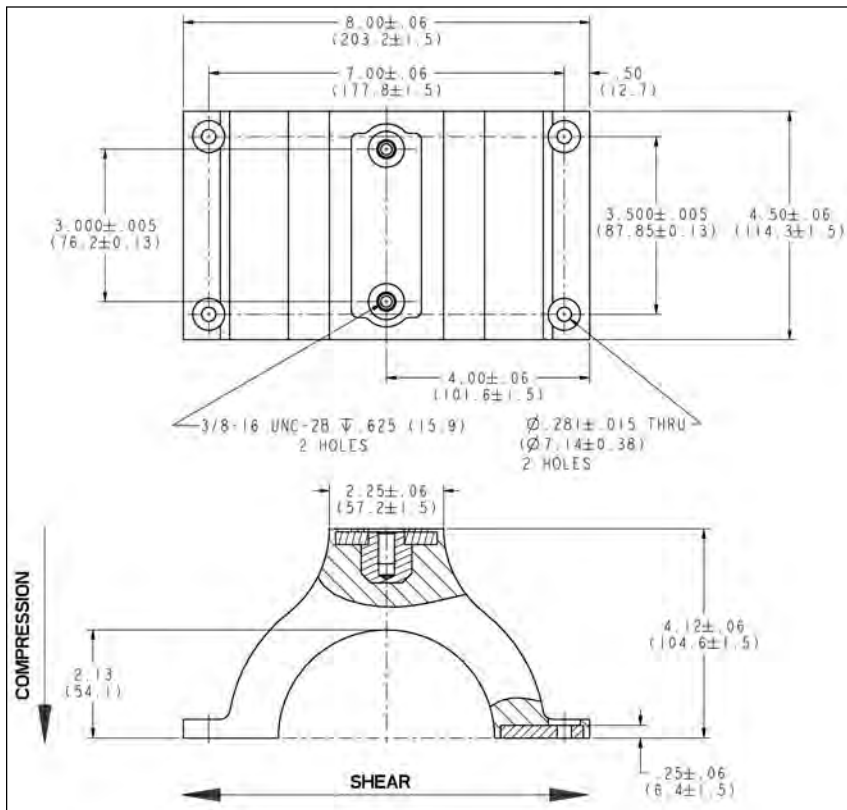

Arch Mount Series: 1975

Dimension and Performance Characteristics

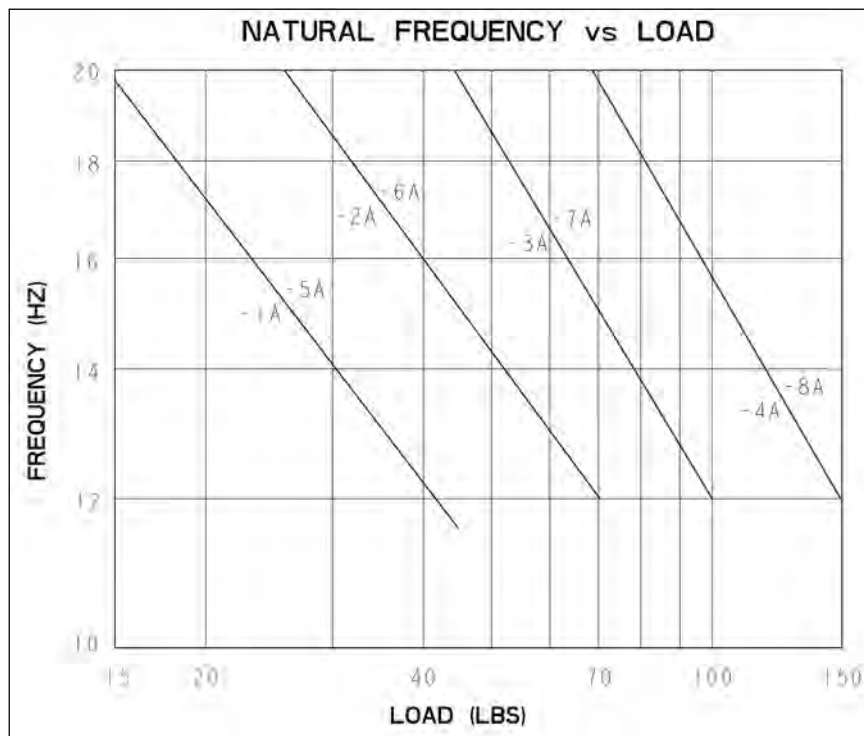
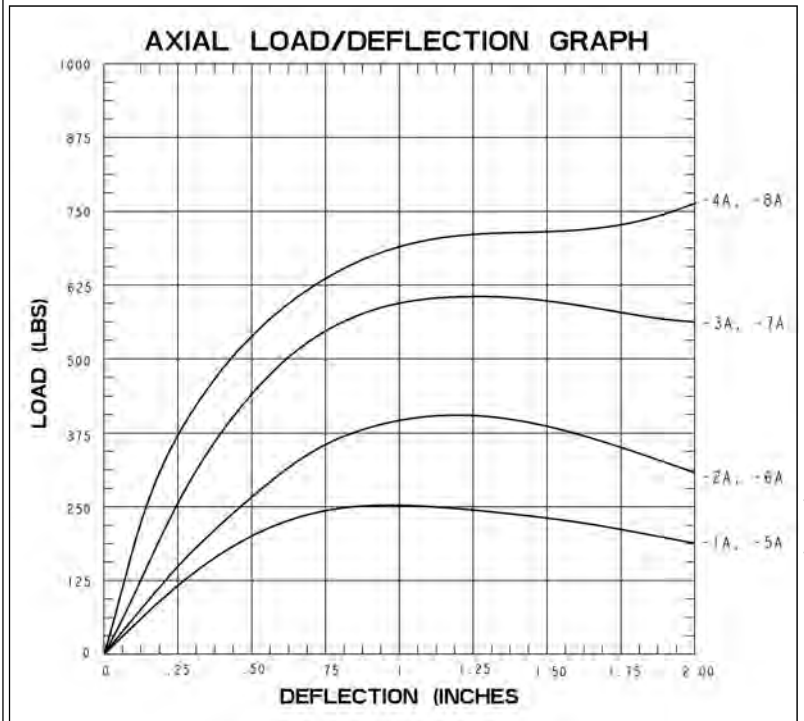
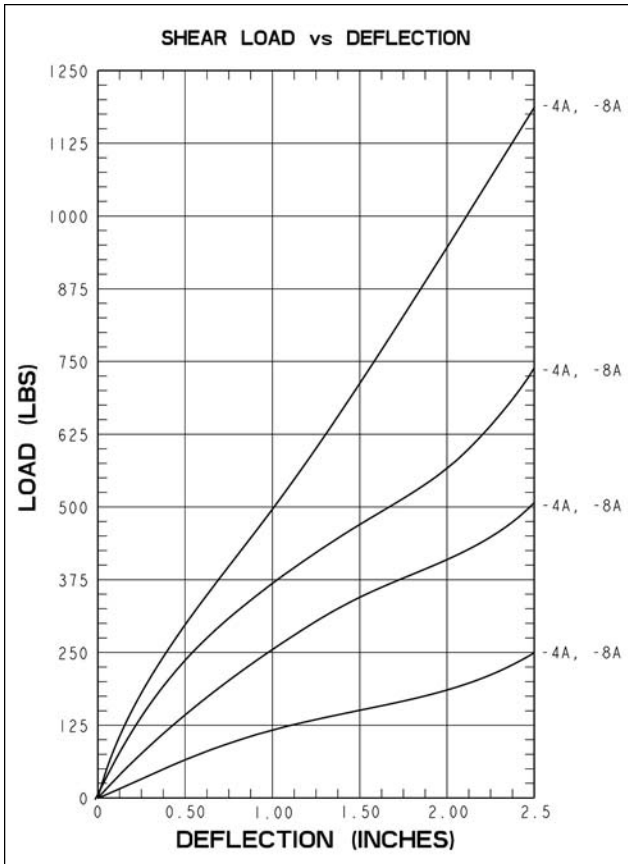

K

LOW PROFILE MOUNT SERIES



1830/1831 Mount Series

A compact, low profile, all attitude shock and vibration isolation solution where instrumentation subjected to serve environmental conditions



Attributes

- High deflection capability for shock load
- Axial to radial stiffness ratio 1:1
- Compact, low profile design
- Easy to install
- Fail-safe
- Survives a 30G, 11 millisecond shock load

Applications

- Military computer applications
- Vehicular equipment
- Missile Electronics
- Light weight electrical equipment in random vibration environments

Load Range

- 1830-1 = load ratings to 3 lbs.
- 1830-2 = load ratings to 4.5 lbs.
- 1830-3 = load ratings to 7 lbs.
- 1830-4 = load ratings to 10 lbs.
- 1831-1 = load ratings to 3 lbs.
- 1831-2 = load ratings to 4.5 lbs.
- 1831-3 = load ratings to 7 lbs.
- 1831-4 = load ratings to 10 lbs.

L

Specifications

- Natural Frequency — 25-40 Hertz
- Transmissibility at resonance — 4.0 max
- Resilient element — Hi-damp silicone
- Standard materials — Aluminum w/zinc plated core
- Weight — 1831 = .023 lbs./1830 = .045 lbs.

Elastomeric Data

- Hi-Damp Silicone operating temperature range is -67°F to +300°F (-55°C to +150°C), elastomer is fungus and ozone resistant
- Other elastomers are available upon request

Mount Series: 1830

Dimension and Performance Characteristics

Part #	Maximum Axial	Load (lbs.) Radial	Axial Natural Frequency (hz)	Standard Material	Standard Elastomer	Core	Hex
1830-1A	3.0	3.0	23	Aluminum	Silicone	8-32 UNC-2B	5/16
1830-1B	3.0	3.0	23	Aluminum	Silicone	.196 Thru	5/16
1830-1C	3.0	3.0	23	Aluminum	Silicone	8-32 UNC-2B	3/8
1830-1D	3.0	3.0	23	Aluminum	Silicone	.196 Thru	3/8
1830-2A	4.5	4.5	24	Aluminum	Silicone	8-32 UNC-2B	5/16
1830-2B	4.5	4.5	24	Aluminum	Silicone	.196 Thru	5/16
1830-2C	4.5	4.5	24	Aluminum	Silicone	8-32 UNC-2B	3/8
1830-2D	4.5	4.5	24	Aluminum	Silicone	.196 Thru	3/8
1830-3A	7.0	7.0	25	Aluminum	Silicone	8-32 UNC-2B	5/16
1830-3B	7.0	7.0	25	Aluminum	Silicone	.196 Thru	5/16
1830-3C	7.0	7.0	25	Aluminum	Silicone	8-32 UNC-2B	3/8
1830-3D	7.0	7.0	25	Aluminum	Silicone	.196 Thru	3/8
1830-4A	10	10	24	Aluminum	Silicone	8-32 UNC-2B	5/16
1830-4B	10	10	24	Aluminum	Silicone	.196 Thru	5/16
1830-4C	10	10	24	Aluminum	Silicone	8-32 UNC-2B	3/8
1830-4D	10	10	24	Aluminum	Silicone	.196 Thru	3/8

Mount Series: 1830

Dimension and Performance Characteristics

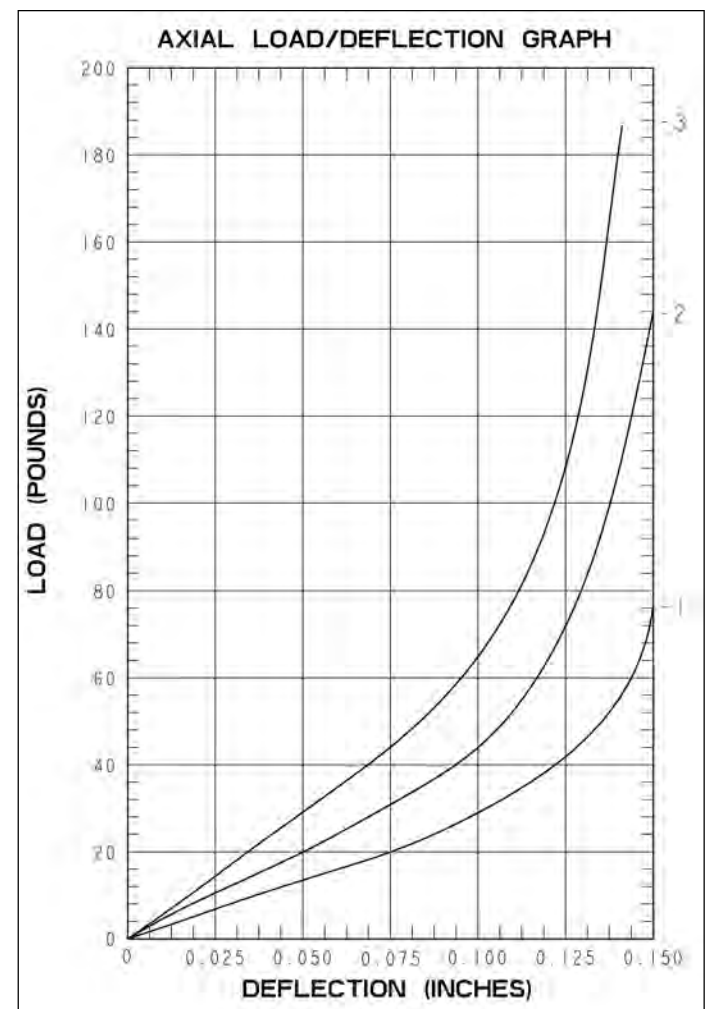
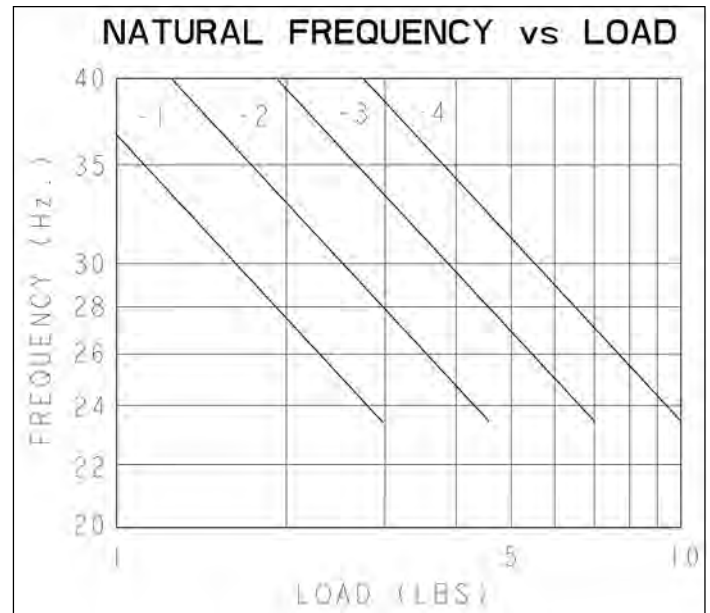
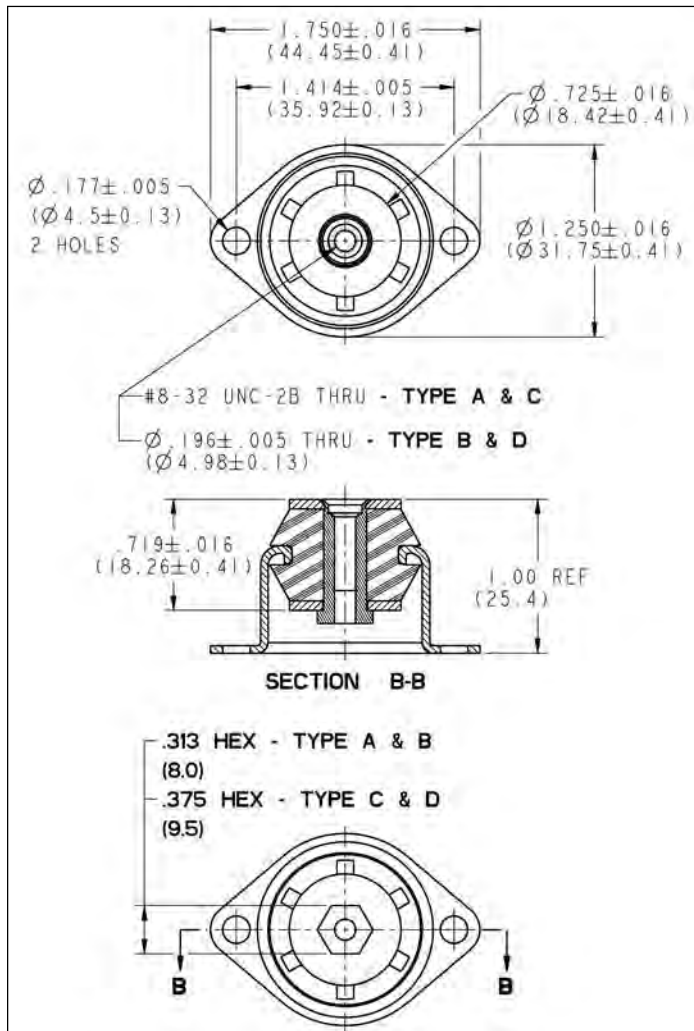

L

Mount Series: 1831

Dimension and Performance Characteristics

Part #	Maximum Axial	Load (lbs.) Radial	Axial Natural Frequency (HZ)	Standard Material	Standard Elastomer	Core	Hex
1831-1A	3.0	3.0	23	Aluminum	Silicone	8-32 UNC-2B	5/16
1831-1B	3.0	3.0	23	Aluminum	Silicone	.196 Thru	5/16
1831-1C	3.0	3.0	23	Aluminum	Silicone	8-32 UNC-2B	3/8
1831-1D	3.0	3.0	23	Aluminum	Silicone	.196 Thru	3/8
1831-2A	4.5	4.5	24	Aluminum	Silicone	8-32 UNC-2B	5/16
1831-2B	4.5	4.5	24	Aluminum	Silicone	.196 Thru	5/16
1831-2C	4.5	4.5	24	Aluminum	Silicone	8-32 UNC-2B	3/8
1831-2D	4.5	4.5	24	Aluminum	Silicone	.196 Thru	3/8
1831-3A	7.0	7.0	25	Aluminum	Silicone	8-32 UNC-2B	5/16
1831-3B	7.0	7.0	25	Aluminum	Silicone	.196 Thru	5/16
1831-3C	7.0	7.0	25	Aluminum	Silicone	8-32 UNC-2B	3/8
1831-3D	7.0	7.0	25	Aluminum	Silicone	.196 Thru	3/8
1831-4A	10	10	24	Aluminum	Silicone	8-32 UNC-2B	5/16
1831-4B	10	10	24	Aluminum	Silicone	.196 Thru	5/16
1831-4C	10	10	24	Aluminum	Silicone	8-32 UNC-2B	3/8
1831-4D	10	10	24	Aluminum	Silicone	.196 Thru	3/8

Mount Series: 1831

Dimension and Performance Characteristics

Recommended hole size is $1.000 \pm .005$ (25.4)

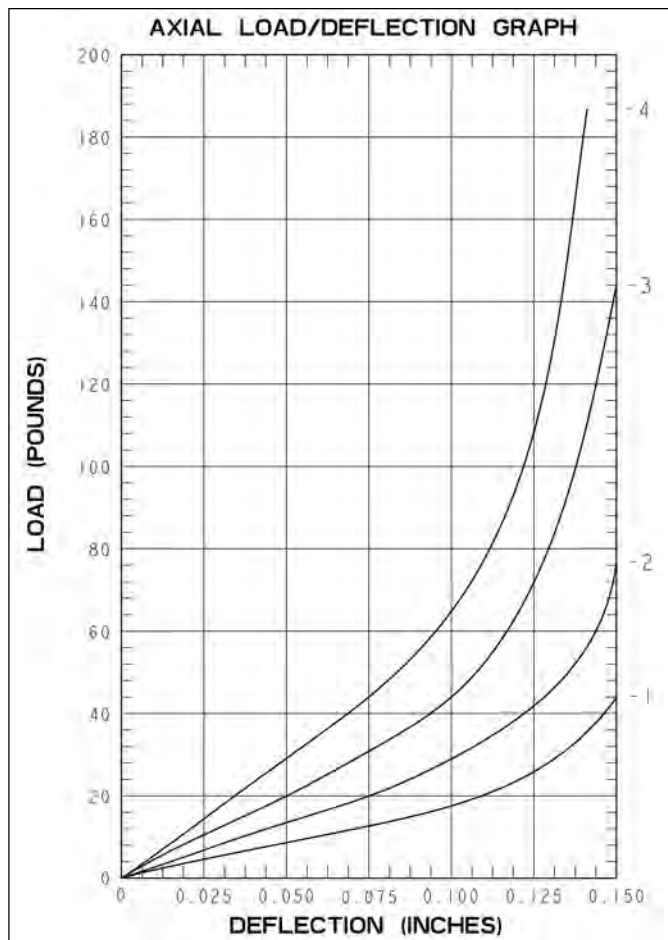
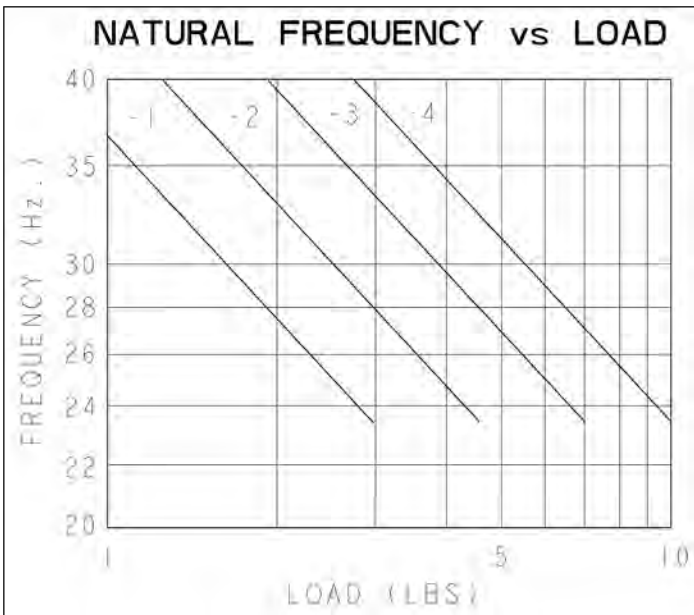
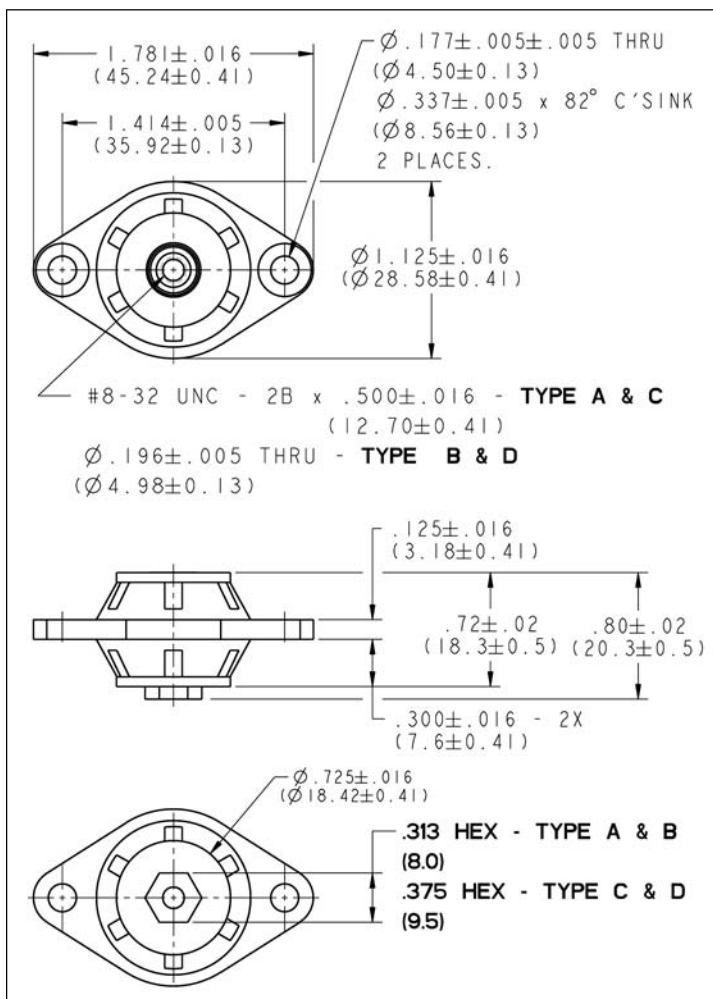

L

Small Equipment Mount Series

SEM100/SEM500

A compact, low profile shock and vibration isolation solution where instrumentation subjected to serve environmental conditions



Applications

- Computer applications
- Avionics
- Electronics
- Commercial/GPS navigation

Load Range

- SEM100-1 = load ratings to 2.5 lbs.
- SEM100-2 = load ratings to 3.75 lbs.
- SEM100-3 = load ratings to 4.25 lbs.
- SEM100-4 = load ratings to 6.5 lbs.
- SEM100-5 = load ratings to 10 lbs.
- SEM500-1 = load ratings to 2 lbs.
- SEM500-2 = load ratings to 3 lbs.
- SEM500-3 = load ratings to 5 lbs.
- SEM500-4 = load ratings to 7.5 lbs.
- SEM500-5 = load ratings to 10 lbs.

Attributes

- High deflection capability for shock load
- Axial to radial stiffness ratio 2:1
- Compact, low profile design
- Easy to install
- Can be used in tandem for higher deflection capability

Specifications

- Natural Frequency — 12-20 Hertz
- Transmissibility at resonance — 10:1 max.
- Resilient Element — Neoprene
- Standard materials — Aluminum
- Weight — SEM100 = 0.2 oz. SEM500 = 0.5 oz.

Elastomeric Data

- Neoprene has an operating temperature range of -40°F to 200°F (-40°C to $+93^{\circ}\text{C}$) and is resistant to oil, most solvents and ozone
- Other elastomeric formulations are available in BUNA-N, Silicone, Butyl and Polybutadiene for improved damping, low and high temperature resistance

Small Equipment Mount Series: SEM100

Dimension and Load Range Specifications

Part #	Maximum Axial Compression	Load Radial (lbs.)	Axial Natural Frequency (hz)	Transmissibility at Resonance	Standard Elastomer	Standard Material	Core Style	Core Hole "B"
SEM100-1	2.5	1.4	14	10:1	Neoprene	6061-T6 Aluminum	Thru Hole	Ø.166
SEM100-2	3.75	1.90	14	10:1	Neoprene	6061-T6 Aluminum	Thru Hole	Ø.166
SEM100-3	4.25	2.75	16	10:1	Neoprene	6061-T6 Aluminum	Thru Hole	Ø.166
SEM100-4	6.5	3.75	16	10:1	Neoprene	6061-T6 Aluminum	Thru Hole	Ø.166
SEM100-5	10.0	6.25	16	10:1	Neoprene	6061-T6 Aluminum	Thru Hole	Ø.166
SEM100-1T	2.5	1.4	14	10:1	Neoprene	6061-T6 Aluminum	Threaded	8-32 UNC-2B
SEM100-2T	3.75	1.90	14	10:1	Neoprene	6061-T6 Aluminum	Threaded	8-32 UNC-2B
SEM100-3T	4.25	2.75	16	10:1	Neoprene	6061-T6 Aluminum	Threaded	8-32 UNC-2B
SEM100-4T	6.5	3.75	16	10:1	Neoprene	6061-T6 Aluminum	Threaded	8-32 UNC-2B
SEM100-5T	10.0	6.25	16	10:1	Neoprene	6061-T6 Aluminum	Threaded	8-32 UNC-2B

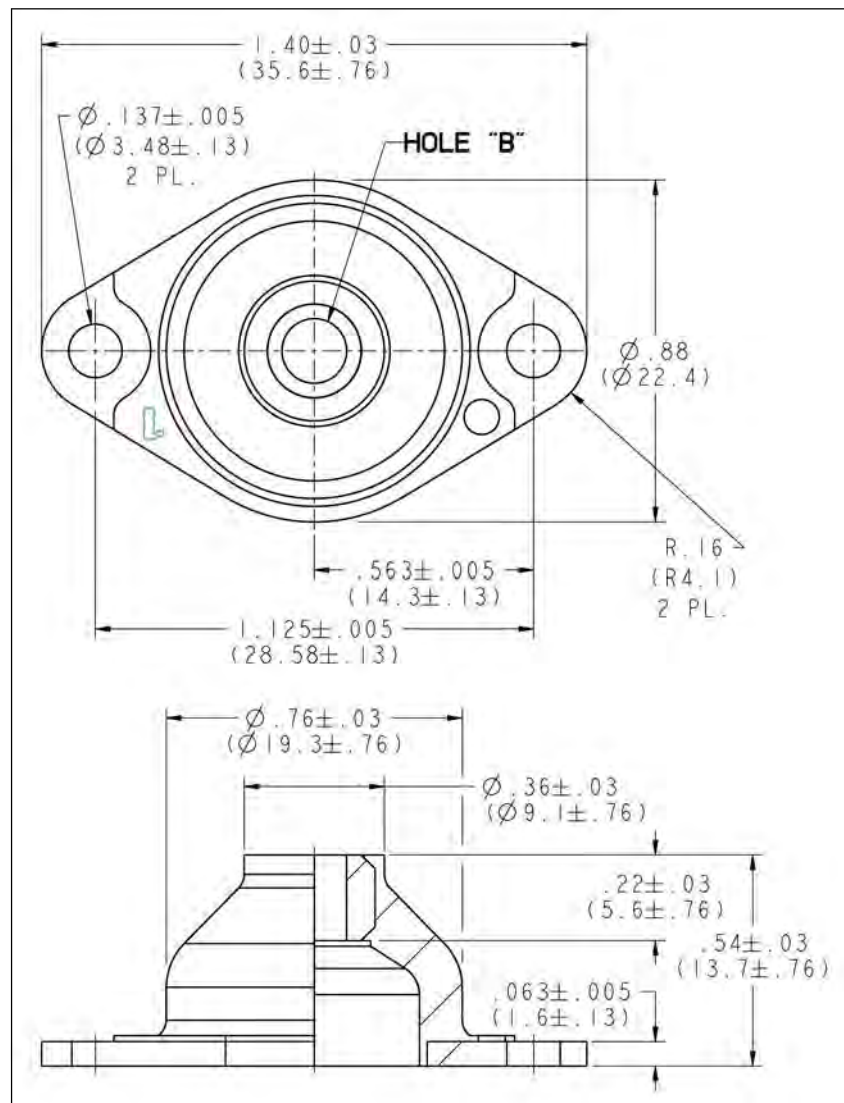

L

Small Equipment Mount Series: SEM100

Dimension and Load Range Specifications

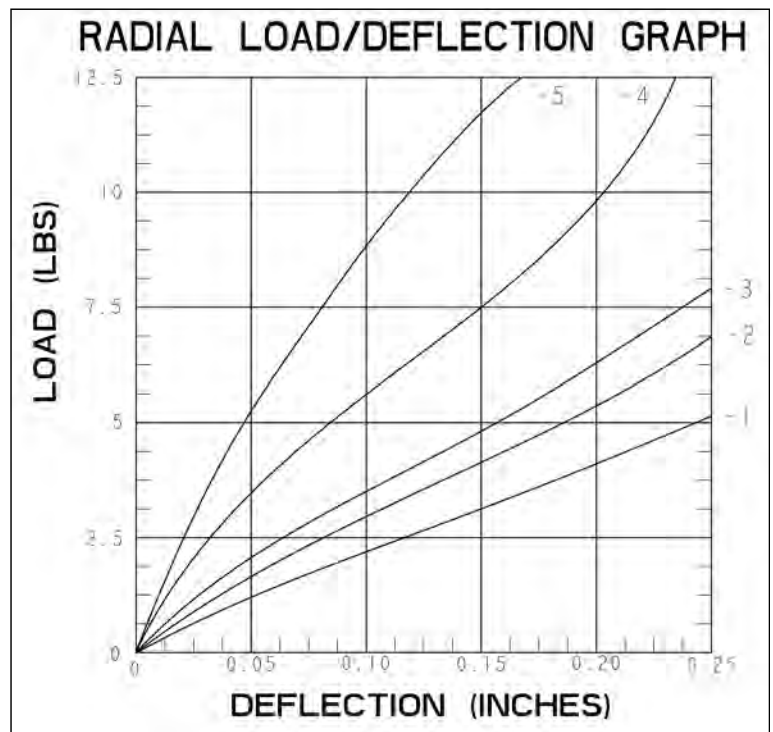
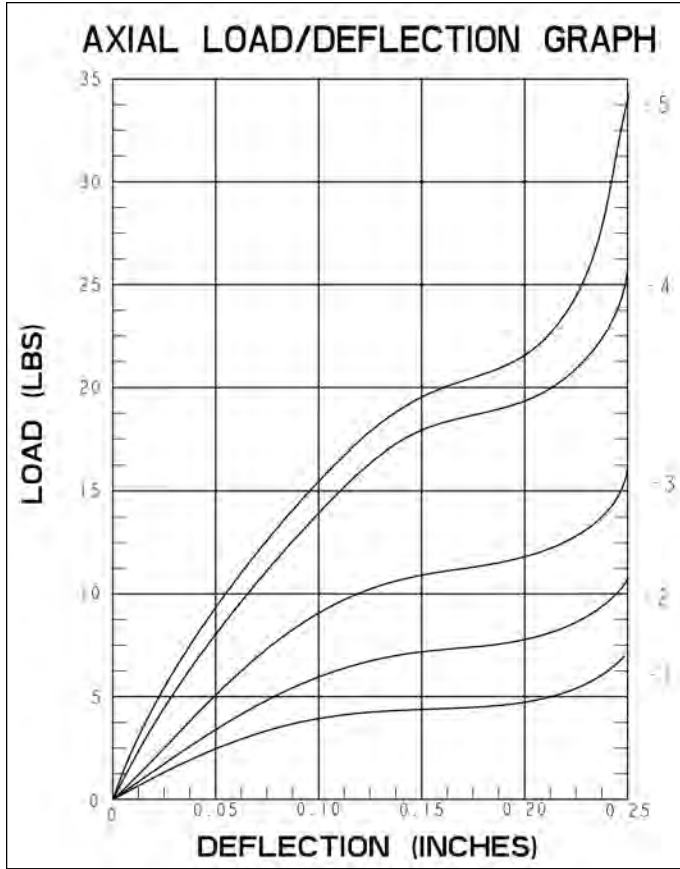

Small Equipment Mount Series: SEM500

Dimension and Load Range Specifications

Part #	Maximum Axial Compression	Load Radial (lbs.)	Axial Natural Frequency (hz)	Transmissibility at Resonance	Standard Elastomer	Standard Material	Core Style	Core Hole "B"
SEM500-1	2.0	.75	12	10:1	Neoprene	6061-T6 Aluminum	Thru Hole	Ø.166
SEM500-2	3.0	1.50	12	10:1	Neoprene	6061-T6 Aluminum	Thru Hole	Ø.166
SEM500-3	5.0	2.25	12	10:1	Neoprene	6061-T6 Aluminum	Thru Hole	Ø.166
SEM500-4	7.5	4.0	12	10:1	Neoprene	6061-T6 Aluminum	Thru Hole	Ø.166
SEM500-5	10.0	5.0	12	10:1	Neoprene	6061-T6 Aluminum	Thru Hole	Ø.166
SEM500-1T	2.0	.75	12	10:1	Neoprene	6061-T6 Aluminum	Threaded	8-32 UNC-2B
SEM500-2T	3.0	1.50	12	10:1	Neoprene	6061-T6 Aluminum	Threaded	8-32 UNC-2B
SEM500-3T	5.0	2.25	12	10:1	Neoprene	6061-T6 Aluminum	Threaded	8-32 UNC-2B
SEM500-4T	7.5	4.0	12	10:1	Neoprene	6061-T6 Aluminum	Threaded	8-32 UNC-2B
SEM500-5T	10.0	5.0	12	10:1	Neoprene	6061-T6 Aluminum	Threaded	8-32 UNC-2B

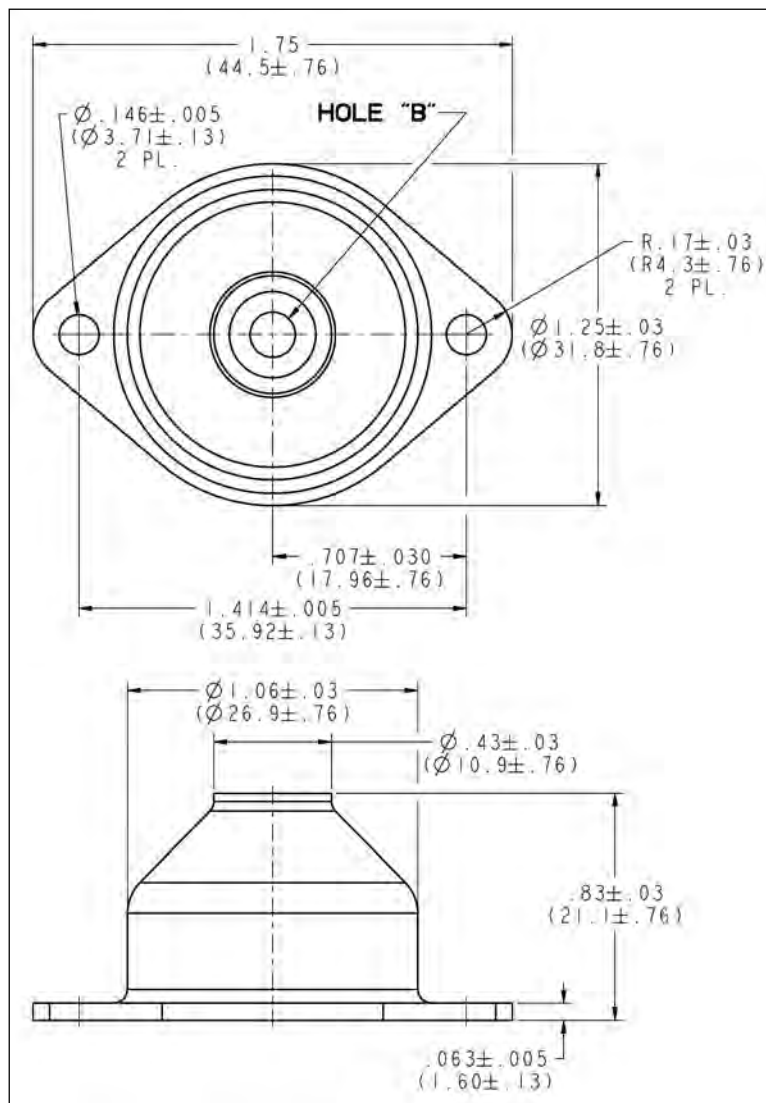

L

Small Equipment Mount Series: SEM500

Dimension and Load Range Specifications

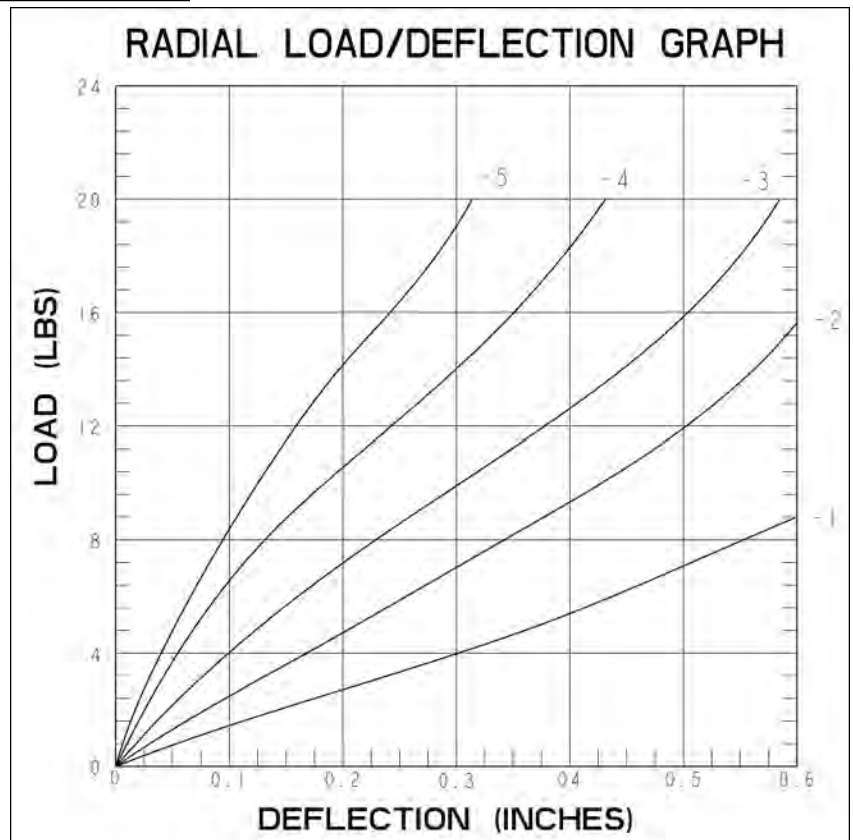
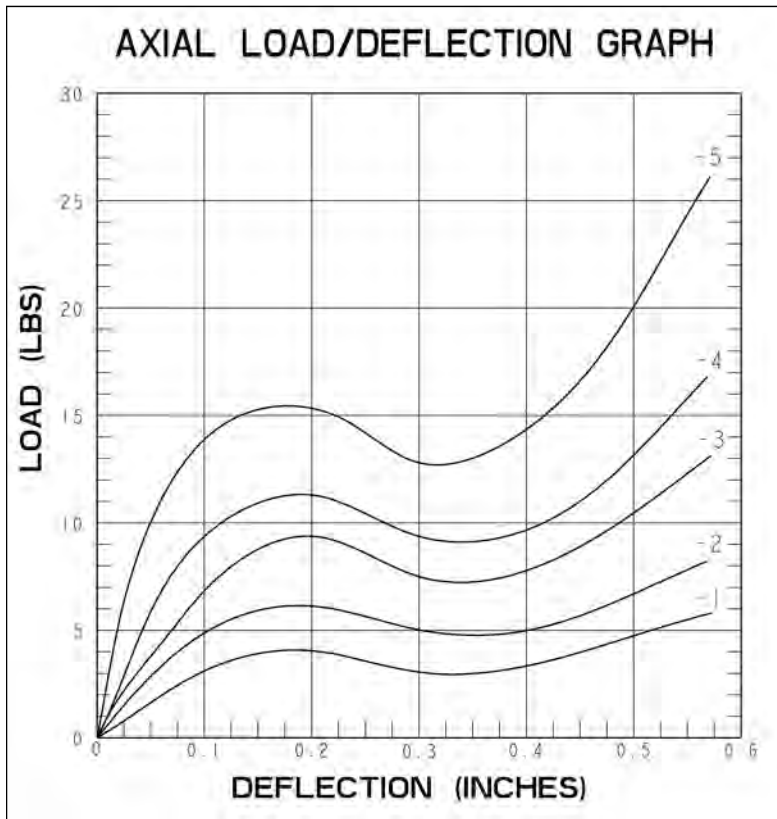

PLATFORM MOUNT SERIES



Platform Mount Series

Versatile, low frequency isolators recommended to isolate steady state vibration and control occasional shock inputs. These lightweight and compact isolators provide multi-directional isolation from lower frequency disturbances

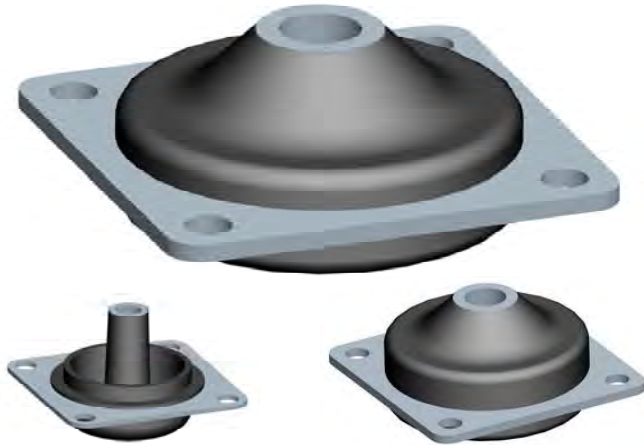

Applications

- Oxygen concentrators
- Gensets
- Engine mounts
- Cab mounts
- Medical equipment
- Compressors
- Electronic equipment

Attributes

- All attitude
- Low cost
- Compact, low profile design
- Available in a square or diamond shaped flange
- Easy to install
- Low natural frequency

Load Range

- EP3001 = 8 load ratings from 4 to 20 lbs.
- EP3002 = 16 load ratings from 3 to 26 lbs.
- EP3003 = 10 load ratings from 12 to 60 lbs.
- EP3004 = 12 load ratings from 20 to 90 lbs.
- EP3106 = 10 load ratings from 1 to 6 lbs.
- EP3156 = 8 load ratings from 6 to 16 lbs.

Specifications

- Natural Frequency — 8-20 Hertz
- Transmissibility at resonance — 10:1
- Resilient Element — Neoprene
- Standard materials — Cold-rolled steel
- Weight — varies with model

Elastomeric Data

- Neoprene has an operating temperature range of -40°F to 200°F (-40°C to $+93^{\circ}\text{C}$) and is resistant to oil, most solvents and ozone
- Other elastomeric formulations are available in BUNA-N, Silicone, Butyl and Polybutadiene for improved damping, low and high temperature resistance

Platform Mount Series: 3001

Dimension and Load Range Specifications

PART NUMBER	MAX STATIC LOAD (lbs.)	AXIAL SPRING RATE (lbs./in.)	A height	B height
EP3001-01	4	62	.75	.45
EP3001-02	8	125	.75	.45
EP3001-03	12	190	.75	.45
EP3001-04	20	330	.75	.45

Diamond Flange

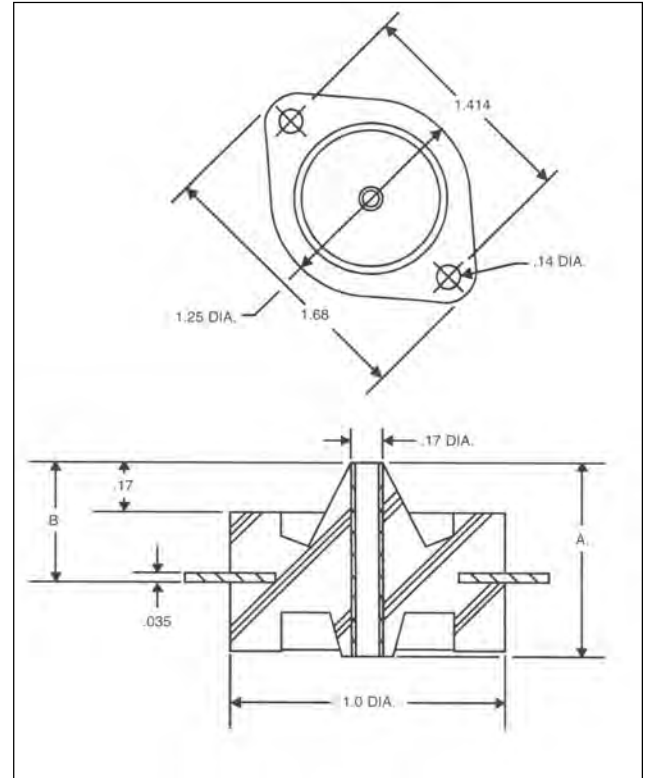

Square Flange

PART NUMBER	MAX STATIC LOAD (lbs.)	AXIAL SPRING RATE (lbs./in.)	A height	B height
EP3001-51	4	62	.75	.45
EP3001-52	8	125	.75	.45
EP3001-53	12	190	.75	.45
EP3001-54	20	330	.75	.45

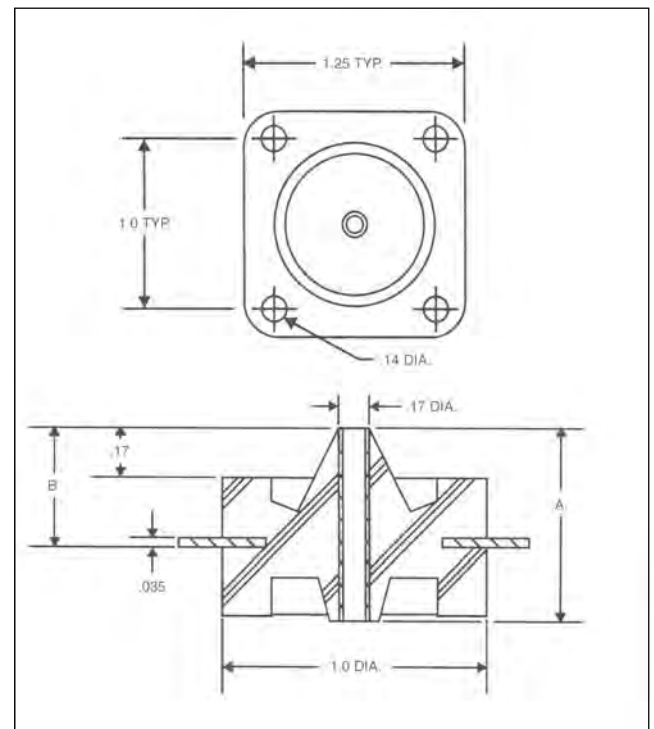

Platform Mount Series: 3002

Dimension and Load Range Specifications

PART NUMBER	MAXIMUM STATIC (lbs.)	AXIAL SPRING RATE (lbs./in.)
EP3002-01	3	33
EP3002-02	6	63
EP3002-03	9	100
EP3002-04	12	130
EP3002-05	14	163
EP3002-06	17	192
EP3002-07	20	220
EP3002-08	26	290

Diamond Flange

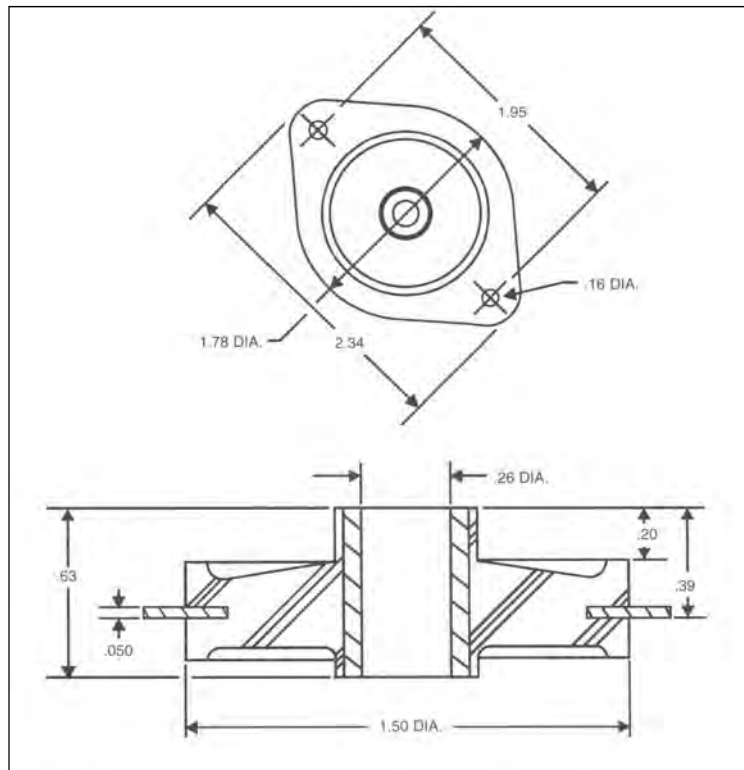

PART NUMBER	MAXIMUM STATIC (lbs.)	AXIAL SPRING RATE (lbs./in.)
EP3002-51	3	33
EP3002-52	6	63
EP3002-53	9	100
EP3002-54	12	130
EP3002-55	14	163
EP3002-56	17	192
EP3002-57	20	220
EP3002-58	26	290

Square Flange

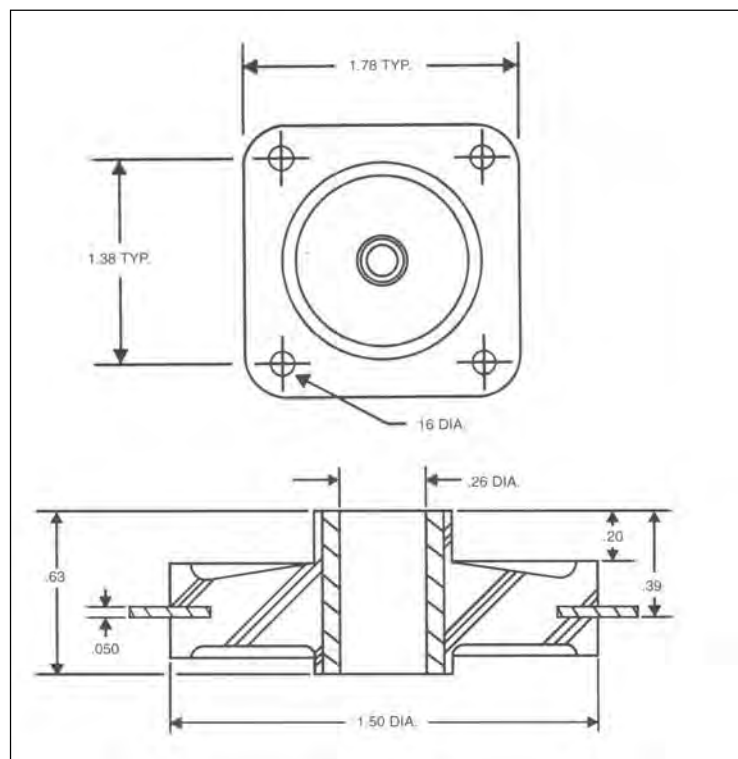

Platform Mount Series: 3003

Dimension and Load Range Specifications

PART NUMBER	MAXIMUM STATIC (lbs.)	AXIAL SPRING RATE (lbs./in.)
EP3003-01	12	67
EP3003-02	20	110
EP3003-03	30	155
EP3003-04	45	240
EP3003-05	60	315

Diamond Flange

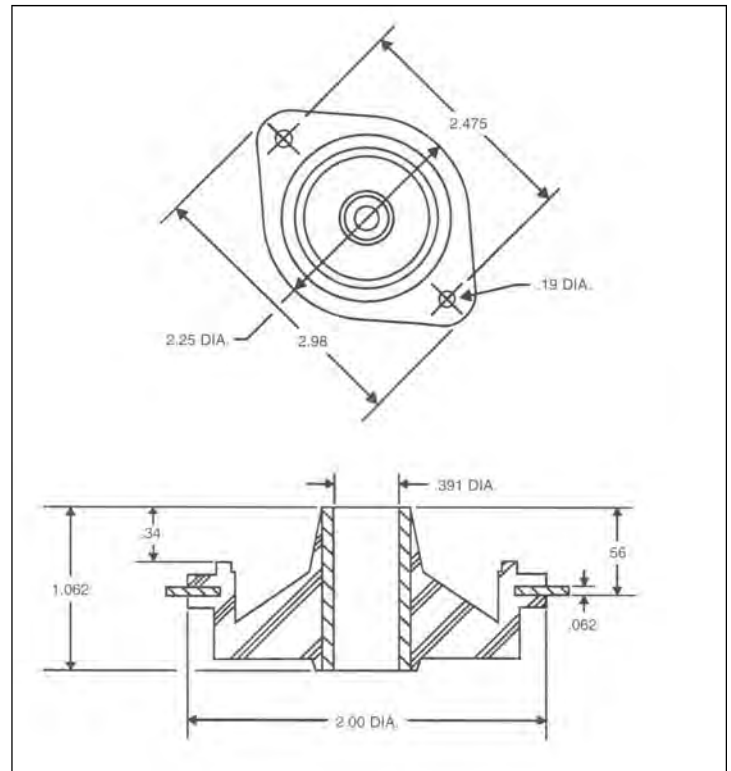

M

Square Flange

PART NUMBER	MAXIMUM STATIC (lbs.)	AXIAL SPRING RATE (lbs./in.)
EP3003-51	12	67
EP3003-52	20	110
EP3003-53	30	155
EP3003-54	45	240
EP3003-55	60	315

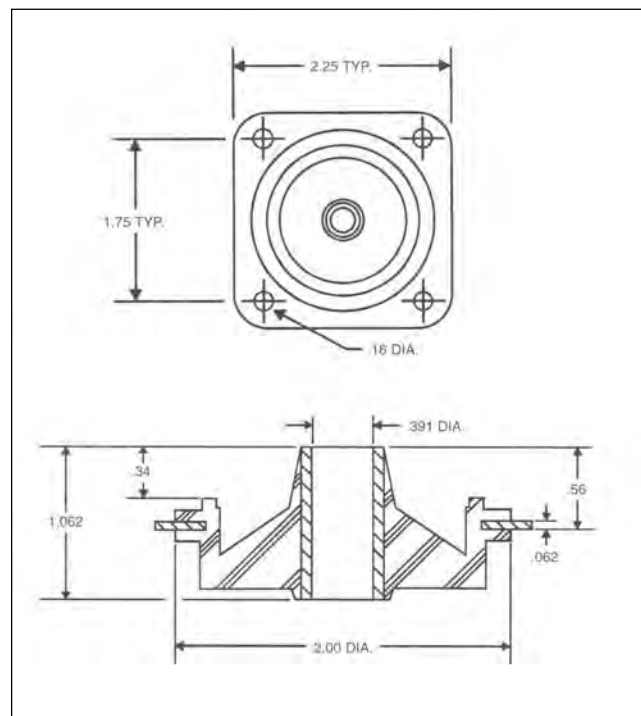

Platform Mount Series: 3004

Dimension and Load Range Specifications

PART NUMBER	MAXIMUM STATIC (lbs.)	AXIAL SPRING RATE (lbs./in.)
EP3004-00	20	160
EP3004-01	30	230
EP3004-02	40	300
EP3004-03	50	385
EP3004-04	70	530
EP3004-05	90	690

Diamond Flange

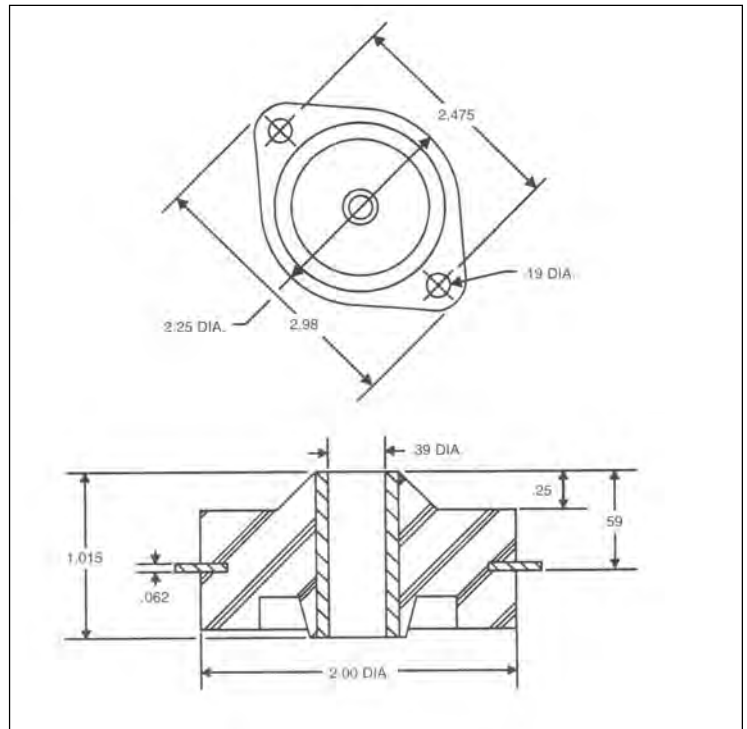

PART NUMBER	MAXIMUM STATIC (lbs.)	AXIAL SPRING RATE (lbs./in.)
EP3004-50	20	160
EP3004-51	30	230
EP3004-52	40	300
EP3004-53	50	385
EP3004-54	70	530
EP3004-55	90	690

Square Flange

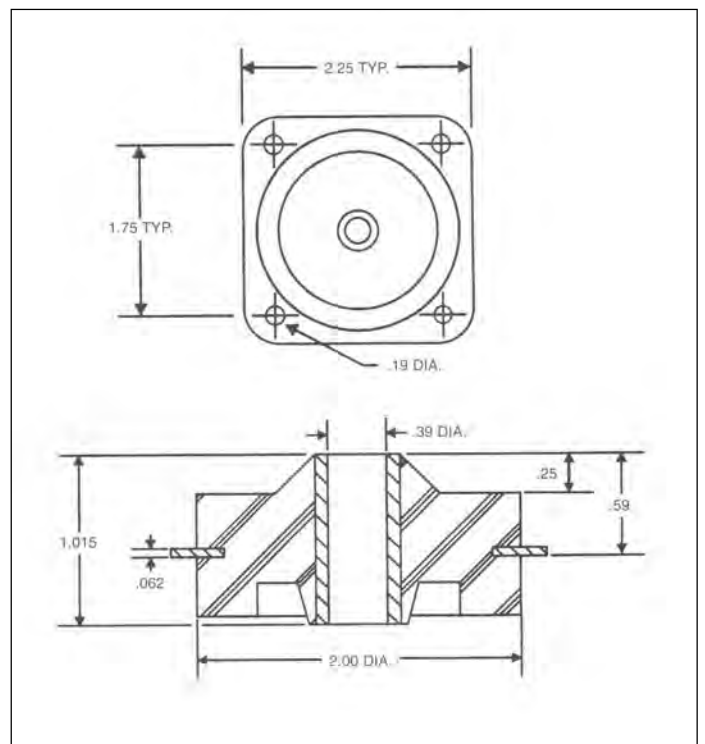

Platform Mount Series: 3106

Dimension and Load Range Specifications

Diamond Flange

PART NUMBER	AXIAL SPRING RATE (lbs./in.)	MAX LOAD (lbs.)	A	D +.008 -.005	E +.003 -.002	F	G	I (MIN)	Q	R	S	U
EP3106-01	5	1	1.00	0.166	0.166	0.032	0.53	0.84	1.414	0.62	1.66	0.38
EP3106-02	11	2										
EP3106-03	16	3										
EP3106-04	21	4										
EP3106-05	32	6										

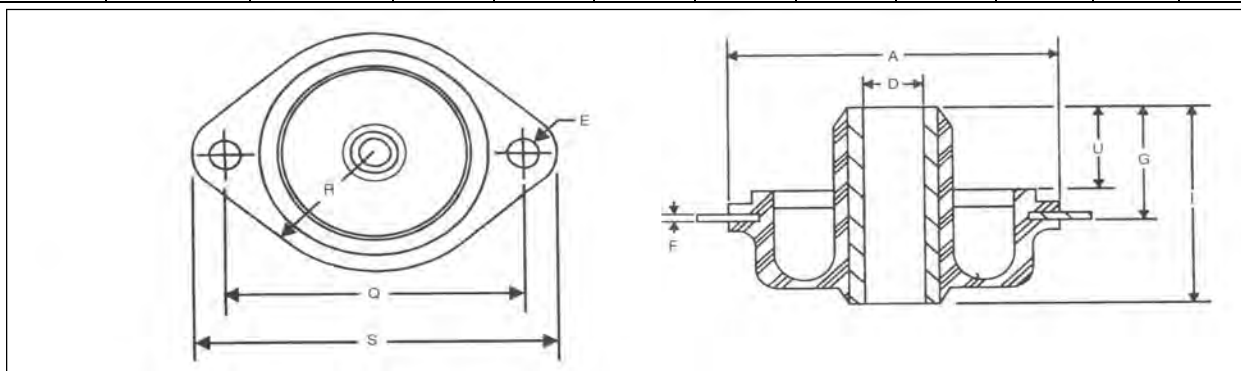

Square Flange

M

PART NUMBER	AXIAL SPRING RATE (lbs./in.)	MAX LOAD (lbs.)	A	B	C	D +.008 -.005	E +.003 -.002	F	G	I	O	U
EP3106-51	5	1	1.00	1.25	1.000	0.166	0.166	0.032	0.53	0.84	1.414	0.38
EP3106-52	11	2										
EP3106-53	16	3										
EP3106-54	21	4										
EP3106-55	32	6										

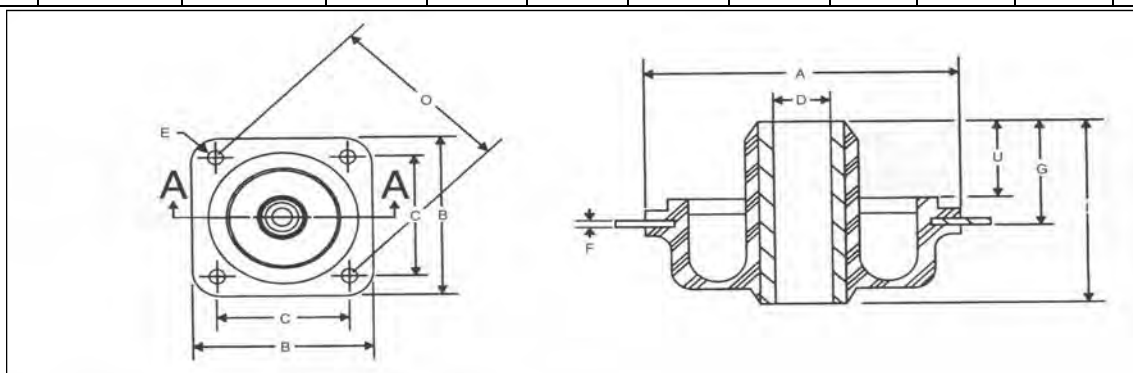

Platform Mount Series: 3156

Dimension and Load Range Specifications

Diamond Flange

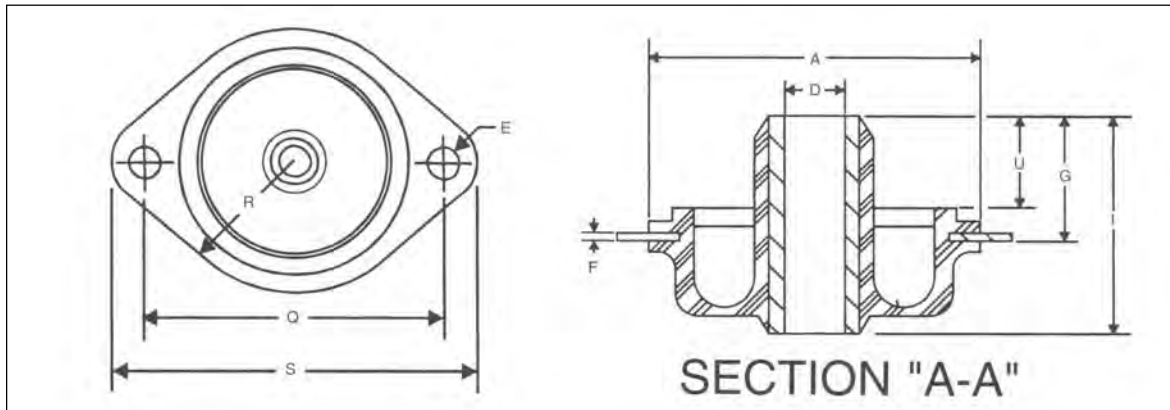

PART NUMBER	AXIAL SPRING RATE (lbs./in.)	MAX LOAD (lbs.)	A	D +0.008 -0.005	E +0.003 -0.002	F	G	I (MIN)	Q	R	S	U
EP3156-01	32	6	1.50	0.257	0.166	0.050	0.55	0.97	1.945	0.88	2.32	0.38
EP3156-02	48	9										
EP3156-03	69	13										
EP3156-04	85	16										

Square Flange

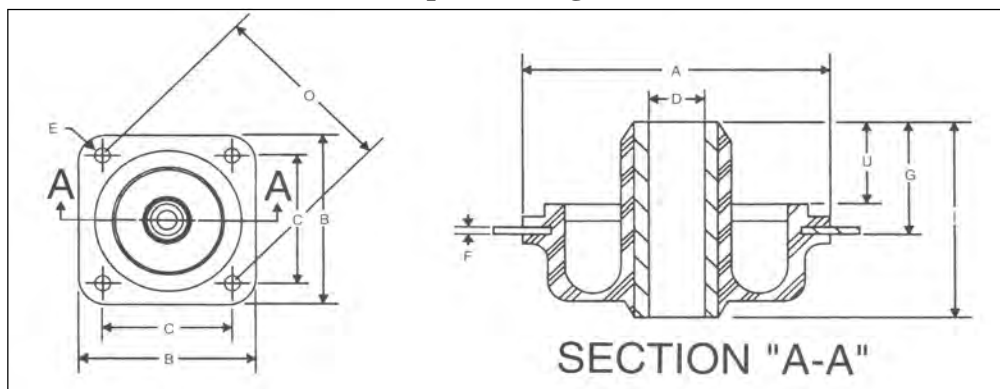

PART NUMBER	AXIAL SPRING RATE (lbs./in.)	MAX LOAD (lbs.)	A	B	C	D +0.008 -0.005	E +0.003 -0.002	F	G	I	O	U
EP3156-51	32	6	1.50	1.75	1.375	0.257	0.166	0.050	0.55	0.97	1.945	0.38
EP3156-52	48	9										
EP3156-53	69	13										
EP3156-54	85	16										

Platform Mount Series: 3011/3020

Dimension and Load Range Specifications

Square Flange

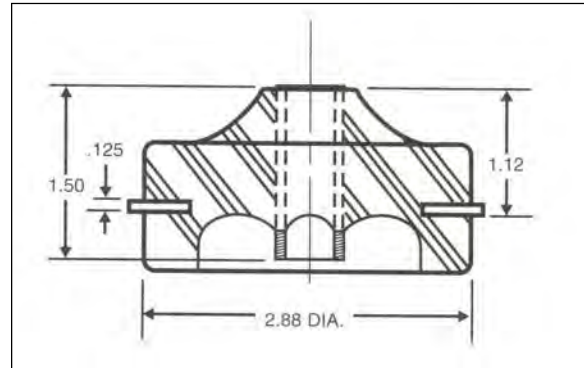
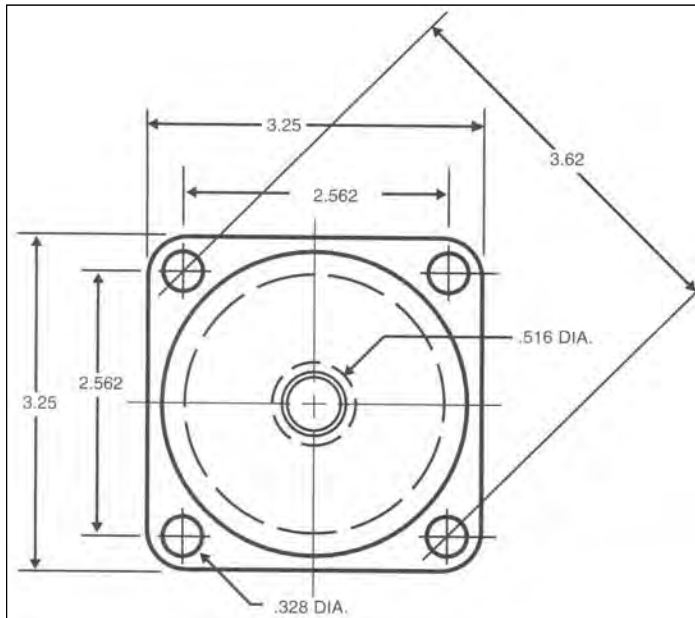

PART NUMBER	DUROMETER
EP3011-01	30
EP3011-02	40
EP3011-03	50
EP3011-04	60
EP3011-05	70

M

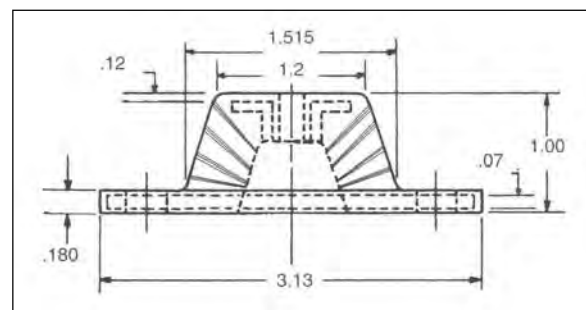
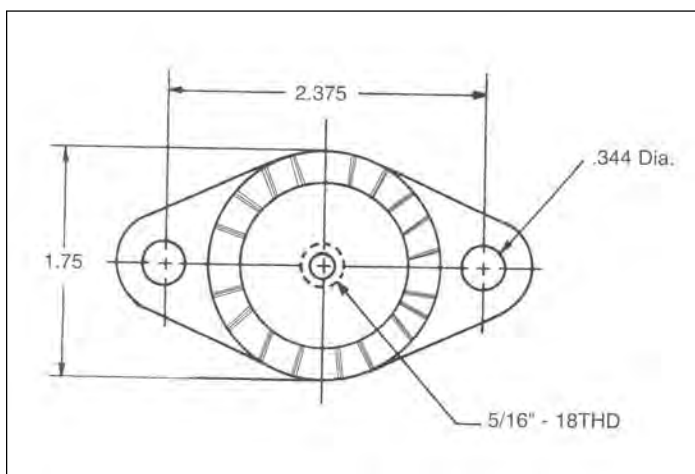

PART NUMBER	DUROMETER
EP3020-01	30
EP3020-02	40
EP3020-03	50
EP3020-04	60
EP3020-05	70

RING AND BUSHING MOUNT SERIES



Ring and Bushing Mount Series

A compact and low profile high capacity shock and vibration isolation solution where instrumentation subjected to severe environmental conditions



Attributes

- Fail-safe
- Axial to radial stiffness ratio 1:1
- Compact, low profile design
- Easy to install
- Rugged design

Applications

- Truck, bus and marine
- Generators, HVAC
- Electronics
- Pumps, compressors, blowers

Load Range

- 1761 = 5 load ratings to 300 lbs. max.
- 1762 = 5 load ratings to 630 lbs. max.
- 1763 = 5 load ratings to 1330 lbs. max.
- 1764 = 5 load ratings to 2100 lbs. max.
- 1765 = 5 load ratings to 4560 lbs. max.

Weights

- 1761 = .10 lbs.
- 1762 = .31 lbs.
- 1763 = .70 lbs.
- 1764 = 1.5 lbs.
- 1765 = 2.8 lbs.

N

Specifications

- Natural Frequency — 8-18 Hertz
- Transmissibility at resonance — 10:1
- Resilient Element — Neoprene
- Standard materials — Cold-rolled steel

Elastomeric Data

- Neoprene has an operating temperature range of -40°F to 200°F (-40°C to +93°C) and is resistant to oils, most solvents and ozone
- Other elastomeric formulations are available in BUNA-N, Silicone, Butyl and Polybutadiene for improved damping, low and high temperature resistance

Ring and Bushing Mount Series: Size 1

Dimension and Load Range Specifications

Part #	Thick Plate Thickness (in.)	Axial Load Thick (lbs.)	Radial Load Thick (lbs.)	Axial Natural Frequency (hz)	Bolt Size Grade 5	Max Torque (ft.-lbs.) Dry
		Thick Plate	Thick Plate	Thick Plate		
1761-30	3/8	40	20	15	3/8	30
1761-40	3/8	90	30	15	3/8	30
1761-50	3/8	140	40	15	3/8	30
1761-60	3/8	250	50	15	3/8	30
1761-70	3/8	300	60	15	3/8	30

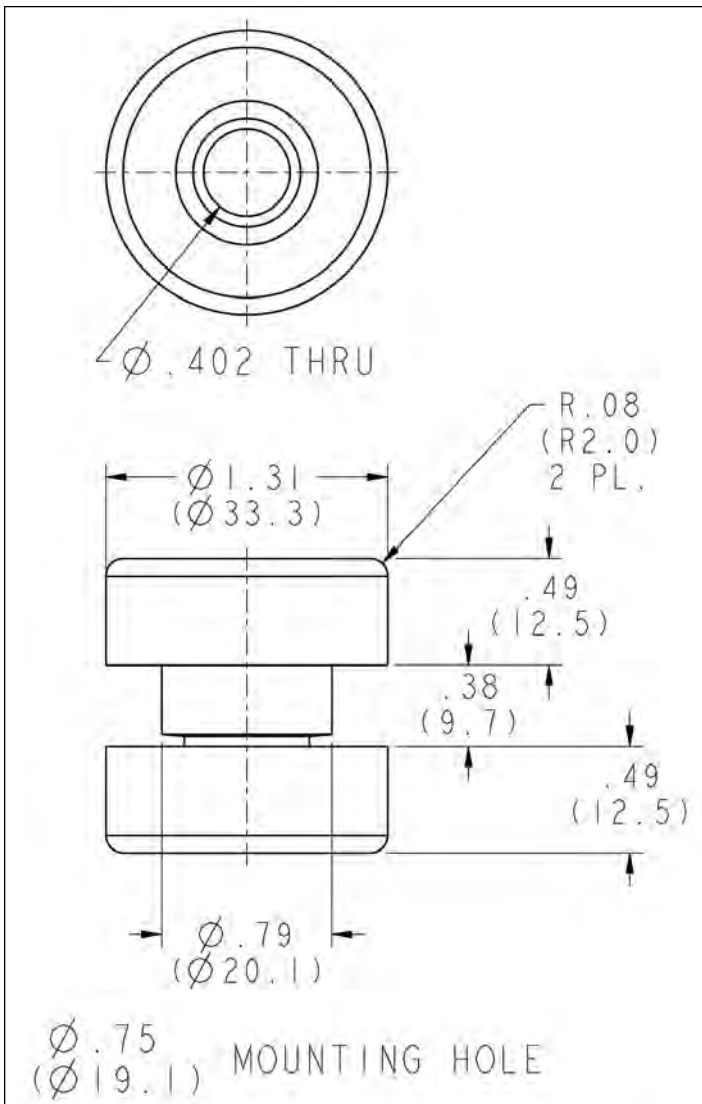

SNUBBING WASHER

P/N SW-1560-0391-0090-SZ

O.D. = $\phi 1.560$ "

I.D. = $\phi .391$ "

THICKNESS = $.090$ "

MATERIAL—1010-1020 CRS

FINISH—CLEAR ZINC

AXIAL LOAD/DEFLECTION GRAPH THICK PLATE STRUCTURE

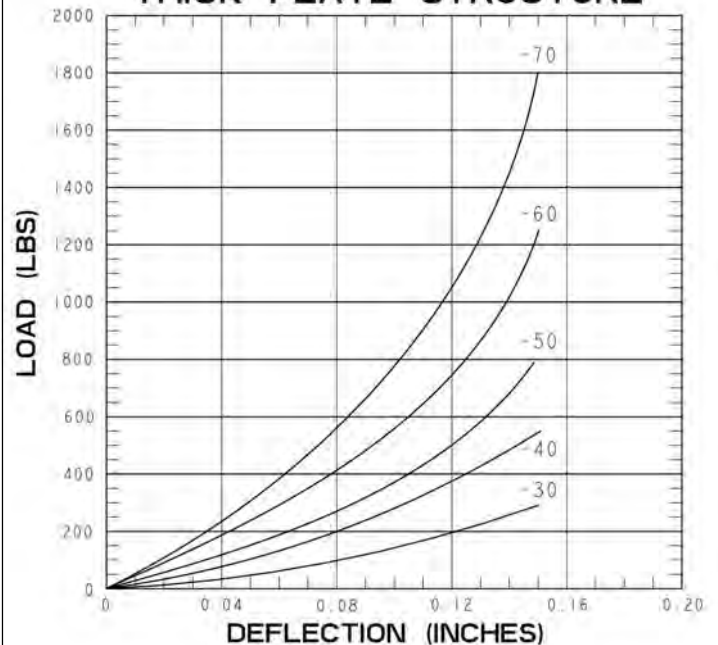

Ring and Bushing Mount Series: Size 2

Dimension and Load Range Specifications

Part #	Thick Plate Thickness (in.)	Axial Load Thick (lbs.)	Radial Load Thick (lbs.)	Axial Natural Frequency (hz.) Thick	Thin Plate Thickness (in.)	Axial Load Thin (lbs.)	Radial Load Thin (lbs.)	Axial Natural Frequency (hz.) Thin	Bolt Size Grade 8	Max Torque (ft.-lbs) Dry
1762-30	18/32	130	50	12	1/2	60	40	15	1/2	120
1762-40	18/32	175	65	12	1/2	120	80	15	1/2	120
1762-50	18/32	240	90	12	1/2	160	125	15	1/2	120
1762-60	18/32	380	165	12	1/2	210	180	15	1/2	120
1762-70	18/32	630	280	12	1/2	380	280	15	1/2	120

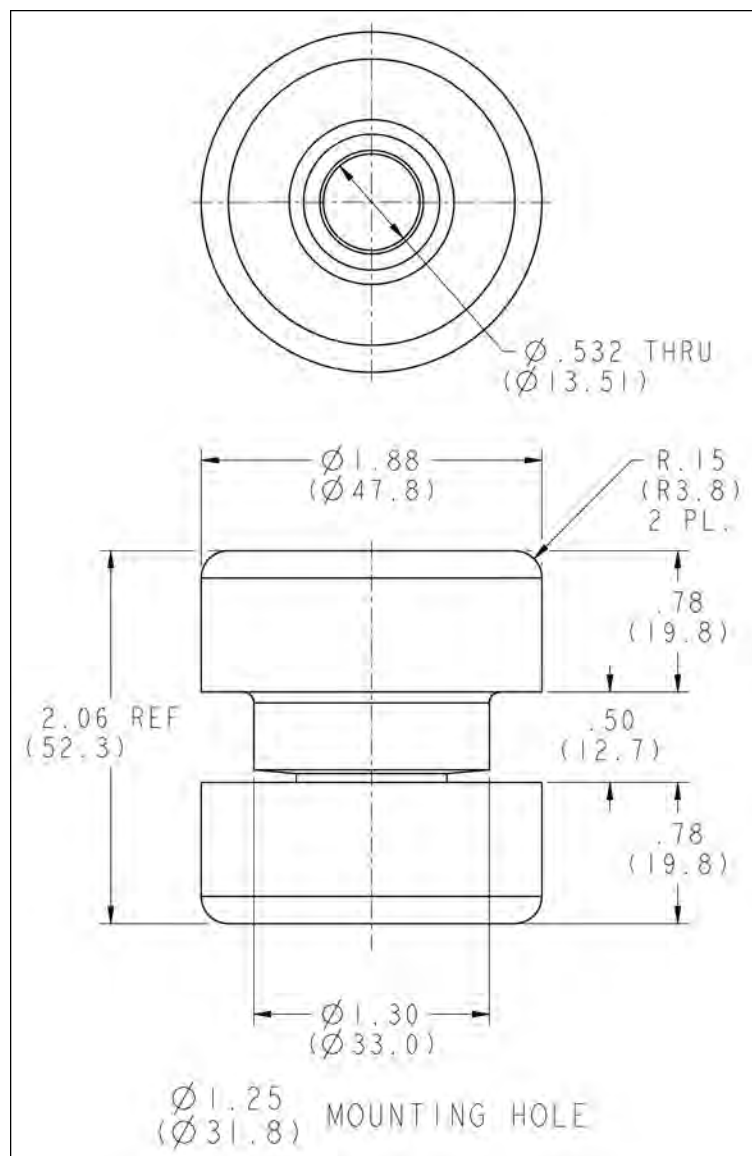

SNUBBING WASHER
P/N SW-2130-0532-0134-SZ
O.D. = ϕ 2.130"
I.D. = ϕ .532"
THICKNESS = .134"
MATERIAL—1010-1020 CRS
FINISH—CLEAR ZINC

N

Ring and Bushing Mount Series: Size 2

Dimension and Load Range Specifications

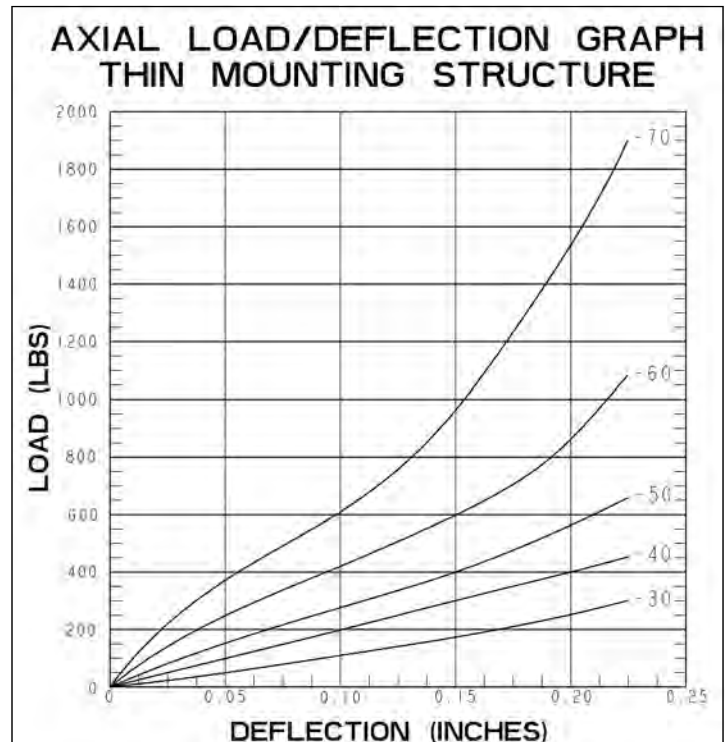
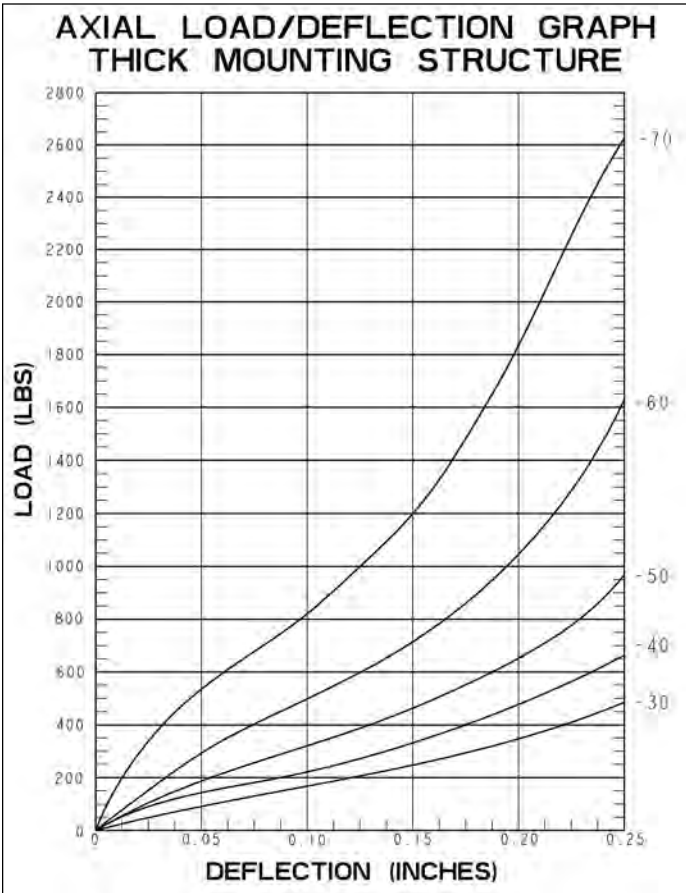

Ring and Bushing Mount Series: Size 3

Dimension and Load Range Specifications

Part #	Thick Plate Thickness (in.)	Axial Load Thick (lbs.)	Radial Load Thick (lbs.)	Axial Natural Frequency (hz.) Thick	Thin Plate Thickness (in.)	Axial Load Thin (lbs.)	Radial Load Thin (lbs.)	Axial Natural Frequency (hz.) Thin	Bolt Size Grade 8	Max Torque (ft.-lbs) Dry
1763-30	7/8	210	90	11	3/4	90	70	15	5/8	220
1763-40	7/8	350	140	11	3/4	150	105	15	5/8	220
1763-50	7/8	490	225	11	3/4	225	160	15	5/8	220
1763-60	7/8	860	385	11	3/4	325	245	15	5/8	220
1763-70	7/8	1330	690	11	3/4	500	360	15	5/8	220

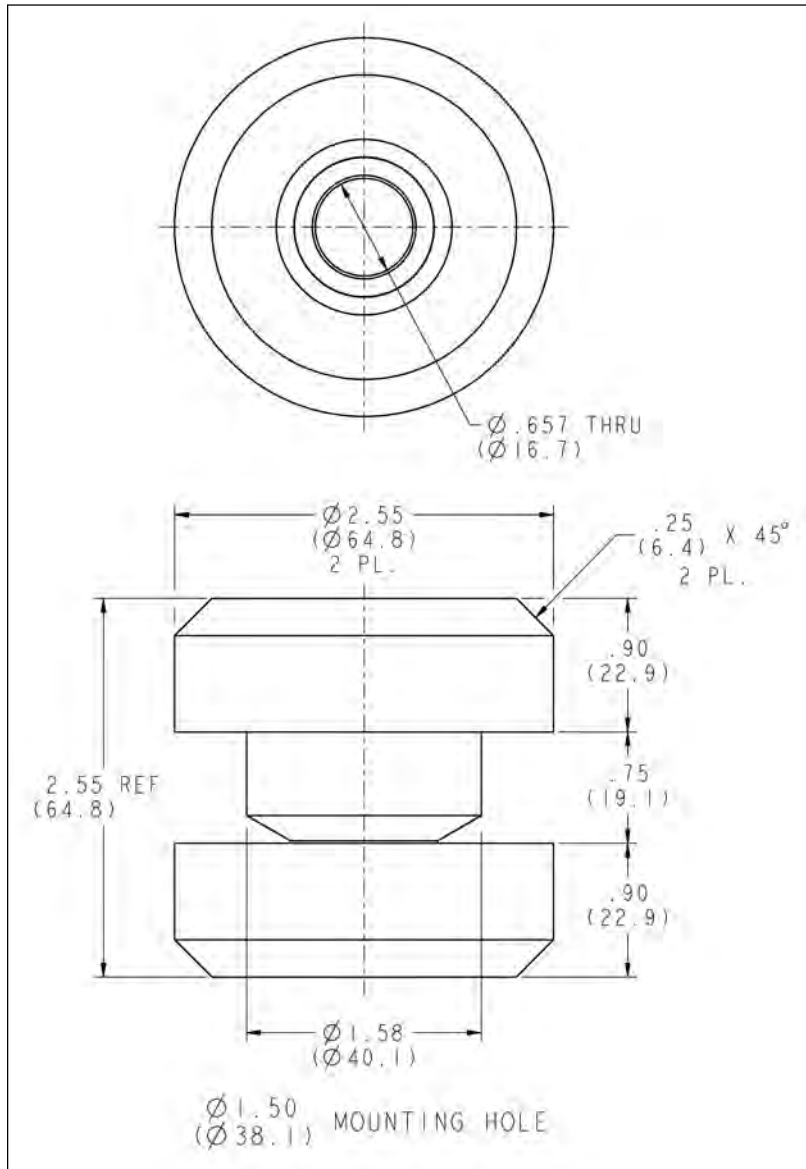

SNUBBING WASHER
P/N SW-2810-0657-0188-SZ
O.D. = $\varnothing 2.810$ "
I.D. = $\varnothing .657$ "
THICKNESS = .188"
MATERIAL—1010-1020 CRS
FINISH—CLEAR ZINC

N

Ring and Bushing Mount Series: Size 3

Dimension and Load Range Specifications

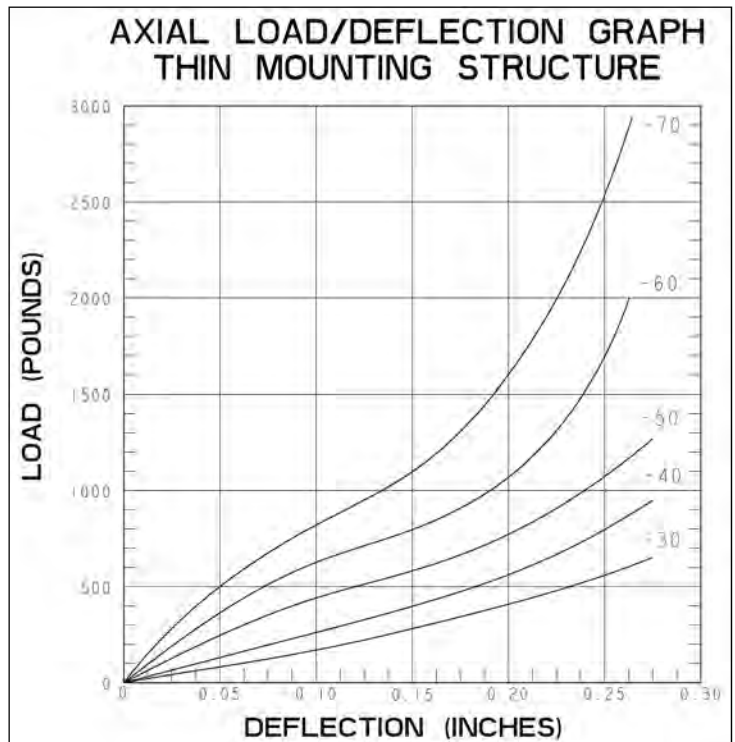
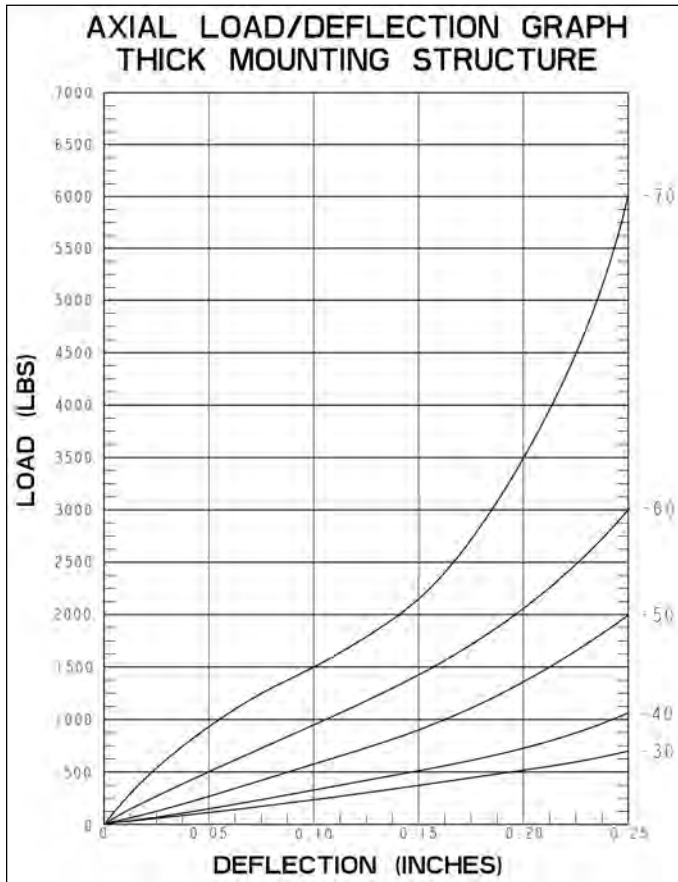

Ring and Bushing Mount Series: Size 4

Dimension and Load Range Specifications

Part #	Thick Plate Thickness (in.)	Axial Load Thick (lbs.)	Radial Load Thick (lbs.)	Axial Natural Frequency (hz.) Thick	Thin Plate Thickness (in.)	Axial Load Thin (lbs.)	Radial Load Thin (lbs.)	Axial Natural Frequency (hz.) Thin	Bolt Size Grade 8	Max Torque (ft.-lbs) Dry
1764-30	1 1/8	270	135	10	1.0	150	110	15	7/8	600
1764-40	1 1/8	510	230	10	1.0	300	220	15	7/8	600
1764-50	1 1/8	770	345	10	1.0	400	300	15	7/8	600
1764-60	1 1/8	1170	590	10	1.0	500	400	15	7/8	600
1764-70	1 1/8	2100	975	10	1.0	600	580	15	7/8	600

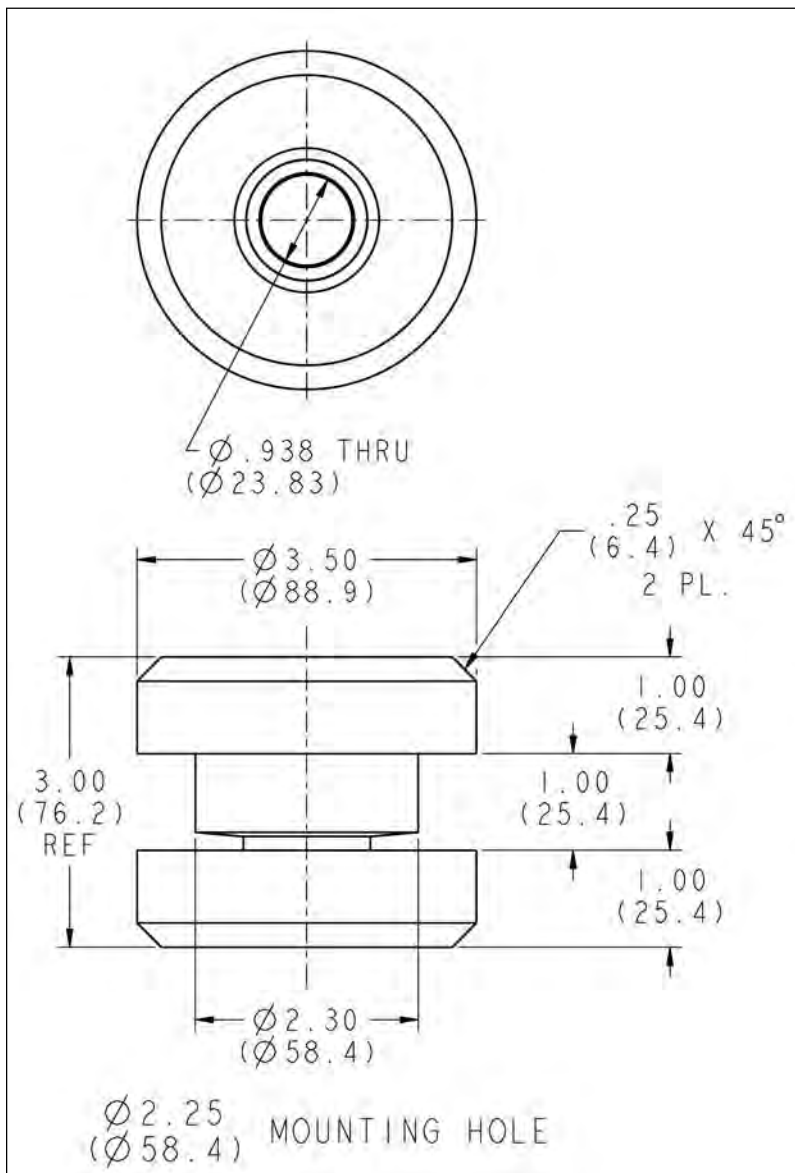

SNUBBING WASHER
P/N SW-3880-0938-0250-SZ
O.D. = $\phi 3.880$ "
I.D. = $\phi .938$ "
THICKNESS = .250"
MATERIAL—1010-1020 CRS
FINISH—CLEAR ZINC

N

Ring and Bushing Mount Series: Size 4

Dimension and Load Range Specifications

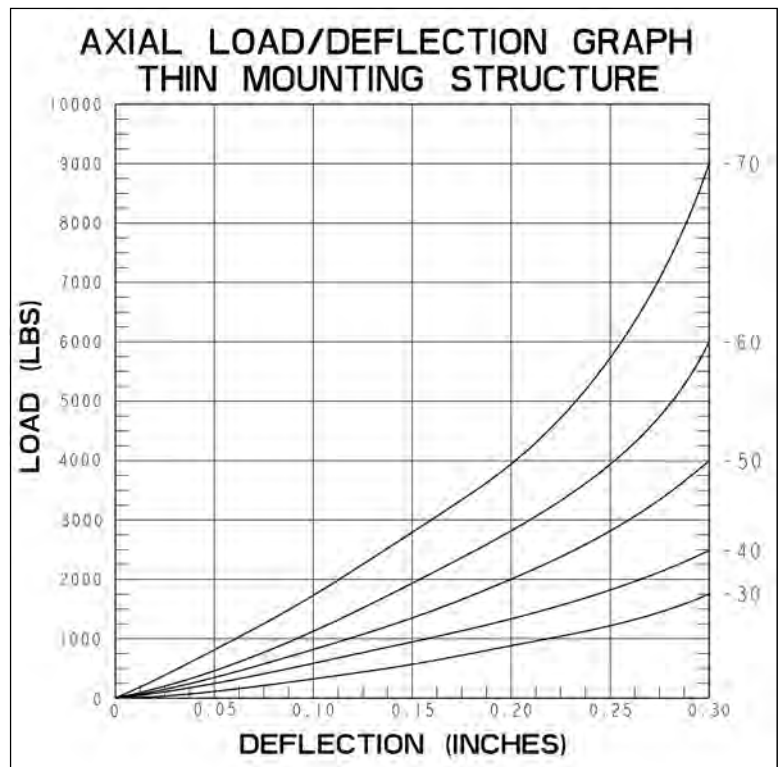
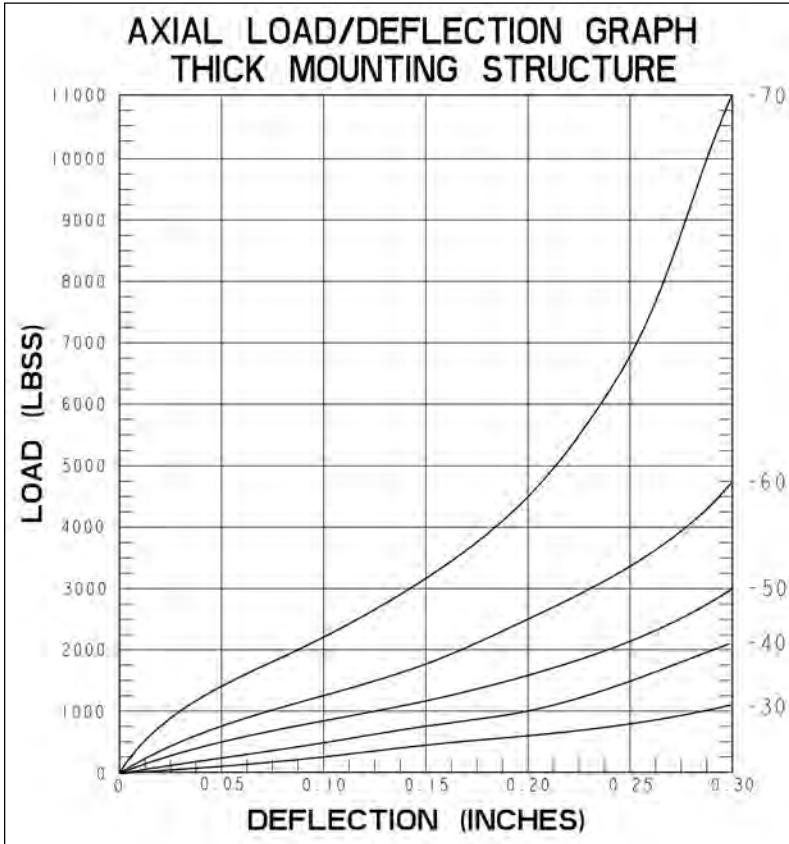

Ring and Bushing Mount Series: Size 5

Dimension and Load Range Specifications

Part #	Thick Plate Thickness (in.)	Axial Load Thick (lbs.)	Radial Load Thick (lbs.)	Axial Natural Frequency (hz.) Thick	Thin Plate Thickness (in.)	Axial Load Thin (lbs.)	Radial Load Thin (lbs.)	Axial Natural Frequency (hz.) Thin	Bolt Size Grade 8	Max Torque (ft.-lbs) Dry
1765-30	1 1/4	1140	240	10	1.0	300	150	15	1.0	900
1765-40	1 1/4	1930	340	10	1.0	500	220	15	1.0	900
1765-50	1 1/4	2580	610	10	1.0	700	300	15	1.0	900
1765-60	1 1/4	3540	890	10	1.0	900	470	15	1.0	900
1765-70	1 1/4	4560	1410	10	1.0	1200	660	15	1.0	900

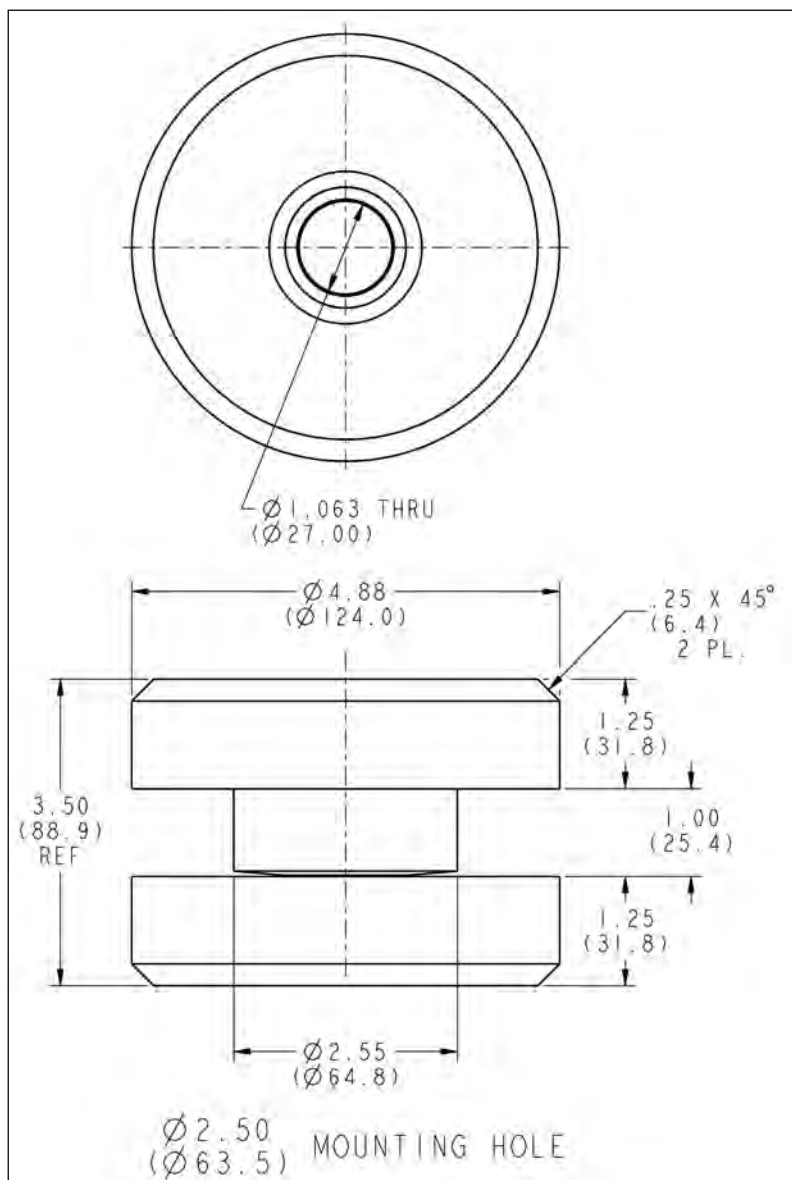

SNUBBING WASHER
P/N SW-5250-1063-0375-SZ
O.D. = $\varnothing 5.250$ "
I.D. = $\varnothing 1.063$ "
THICKNESS = .375"
MATERIAL—1010-1020 CRS
FINISH—CLEAR ZINC

N

Ring and Bushing Mount Series: Size 5

Dimension and Load Range Specifications

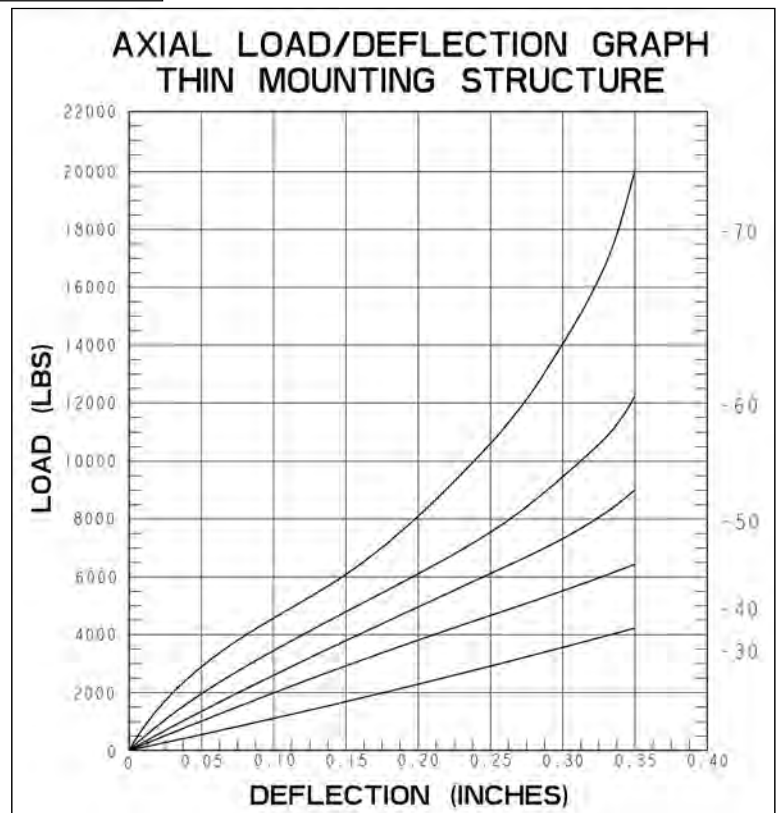
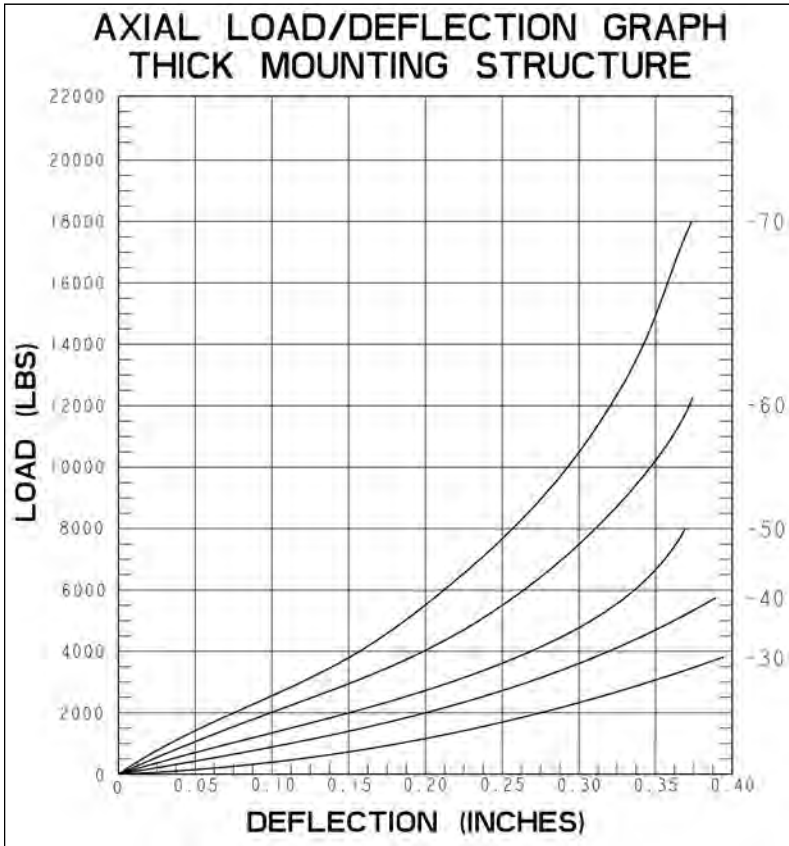

Ring and Bushing Mount Series

Dimension and Load Range Specifications

Part #	Mounting Hole Diameter	Mounting Hole Radius	Snubbing Washer Part Number	Snubbing Washer OD	Snubbing Washer ID	Snubbing Washer Thickness
1761	.75	.04	SW 1560-0391-0090-SZ	1.560	.391	.090
1762	1.25	.06	SW-2130-0532-0134-SZ	2.130	.532	.134
1763	1.50	.09	SW-2810-0657-0188-SZ	2.810	.657	.188
1764	2.25	.12	SW-3880-0938-0250-SZ	3.880	.938	.250
1765	2.50	.13	SW-5250-1063-0375-SZ	5.250	1.063	.375

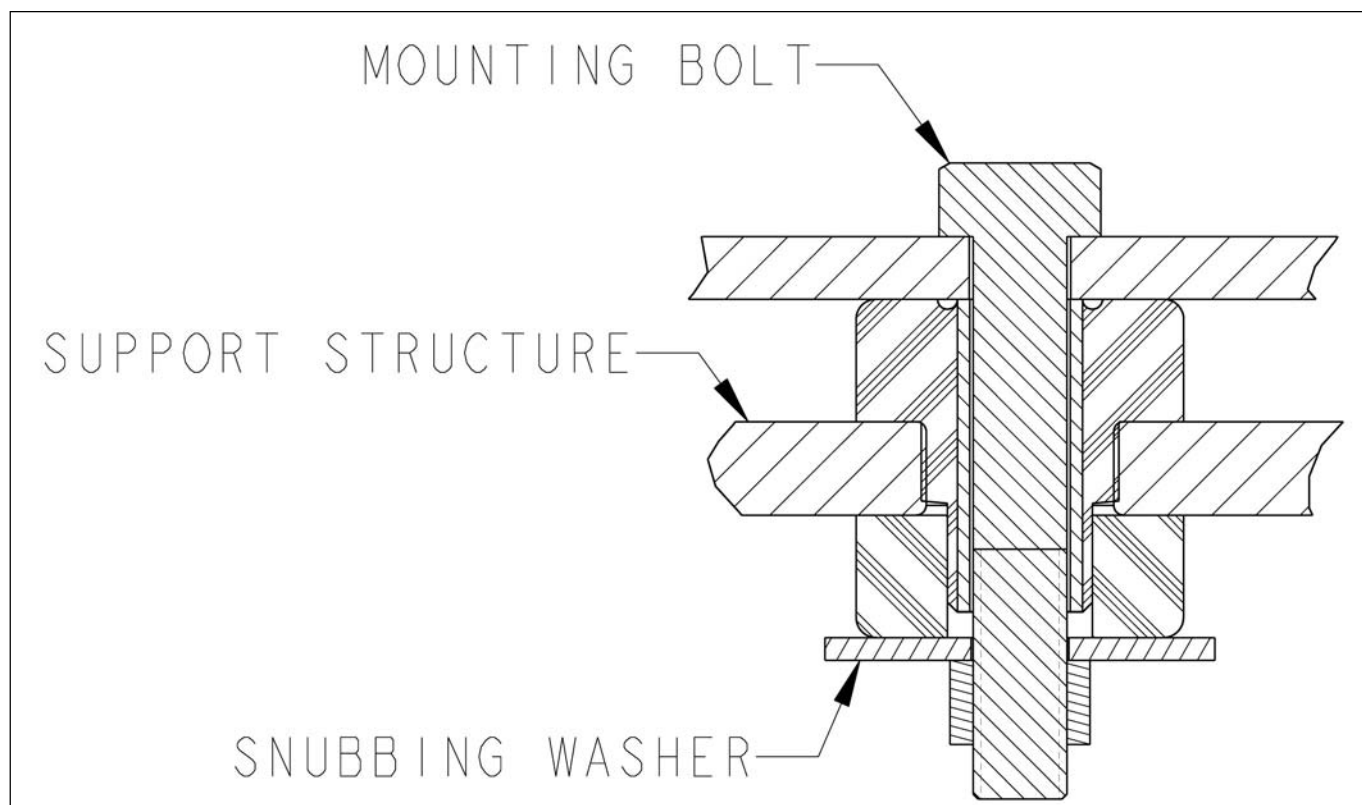

Bushing Series

Armor Plated Corners

A low profile, easily installed, rugged mount rated for the high vibration and shock inputs of industrial and military applications



Attributes

- Chamfering of mounting plate is not required
- Bonded metal inserts allow the mount to be used on cut holes in the mounting surface
- Dimensions and load ratings are the same as Ring and Bushing Series 1761-1765
- Ribs hold part in place during installation
- Identical top and bottom halves—no orientation mistakes, less part numbers
- Axial to radial stiffness 4:1
- Fail-safe design with snubbing washer

Applications

- Construction equipment
- Agricultural equipment
- Engine mounting
- Commercial lawn care equipment
- Power generators

Load Range

- 2061 = load ratings to 300 lbs.
- 2062 = load ratings to 630 lbs.
- 2063 = load ratings to 1330 lbs.
- 2064 = load ratings to 2100 lbs.
- 2065 = load ratings to 4560 lbs.

Specifications

- Natural Frequency — 10-20 Hertz
- Transmissibility at resonance — 10:1
- Resilient Element — Neoprene or Natural Rubber
- Standard materials — Cold-rolled steel
- Weight — See dimensional drawings

Elastomeric Data

- Neoprene elastomer has an operating temperature range of -40°F to 200°F (-40°C to $+93^{\circ}\text{C}$) and is resistant to most oils and ozone.
- Natural Rubber has an operating temperature range of -25°F to $+160^{\circ}\text{F}$ (-37°C to $+70^{\circ}\text{C}$)
- Additional elastomers are available upon request.

Bushing Series: 2061—2065

Dimension and Load Range Specifications

Part #	Ø A Inch (metric)	Ø B Inch (metric)	C Inch (metric)	C Installed Inch (metric)	D Inch (metric)	Ø E Inch (metric)	Weight lbs./oz. (grams)	Axial Load Ratings (max. lbs.) /kg.	Plate Thickness (in.) “F” (metric)	Bolt Size	Grade	Max Torque (ft.-lbs.)	Elastomer Material											
2061-1	1.31 (33.3)	.397 (10.1)	0.50 (12.7)	0.44 (11.2)	1.25 (31.8)	.730 (18.5)	1.5 oz (43)	40/18	.375” (9.52)	3/8”	5	30	Natural Rubber											
2061-2								90/41					Natural Rubber											
2061-3								140/64					Natural Rubber											
2061-4								250/113					Natural Rubber											
2061-5								300/136					Natural Rubber											
2061-11								40/18					Neoprene											
2061-12								90/41					Neoprene											
2061-13								140/64					Neoprene											
2061-14								250/113					Neoprene											
2061-15								300/136					Neoprene											
2062-1								1.88 (47.8)					.532 (13.5)	0.78 (19.8)	0.69 (17.5)	1.94 (49.3)	1.23 (31.2)	5.0 oz (142)	130/59	.563” (14.3)	1/2”	8	120	Natural Rubber
2062-2																			175/79					Natural Rubber
2062-3																			240/109					Natural Rubber
2062-4																			380/172					Natural Rubber
2062-5																			630/286					Natural Rubber
2062-11	130/59	Neoprene																						
2062-12	175/79	Neoprene																						
2062-13	240/109	Neoprene																						
2062-14	380/172	Neoprene																						
2062-15	630/286	Neoprene																						
2063-1	2.55 (64.8)	.657 (16.7)	0.90 (22.9)	0.78 (19.8)	2.43 (61.7)	1.48 (37.6)	11.0 oz (312)		210/95	.875” (22.2)	5/8”	8							220					Natural Rubber
2063-2									350/159															Natural Rubber
2063-3									490/222															Natural Rubber
2063-4									775/350															Natural Rubber
2063-5									1100/500															Natural Rubber
2063-11								210/95	Neoprene															
2063-12								350/159	Neoprene															
2063-13								490/222	Neoprene															
2063-14								775/350	Neoprene															
2063-15								1100/500	Neoprene															

Chart continued on next page....

Bushing Series: 2061—2065

Dimension and Load Range Specifications

Part #	Ø A Inch (metric)	Ø B Inch (metric)	C Inch (metric)	C Installed Inch (metric)	D Inch (metric)	Ø E Inch (metric)	Weight lbs./oz. (grams)	Axial Load Ratings (max. lbs.) /kg.	Plate Thickness (in.) "F" (metric)	Bolt Size	Grade	Max Torque (ft.-lbs.)	Elastomer Material											
2064-1	3.50 (89.0)	.938 (23.8)	1.00 (25.4)	0.88 (22.4)	2.88 (73.2)	2.23 (56.0)	1 lb 7.5 oz (667)	270/122	1 1/8"	7/8"	8	600	Natural Rubber											
2064-2								510/231					Natural Rubber											
2064-3								770/349					Natural Rubber											
2064-4								1170/530					Natural Rubber											
2064-5								2100/952					Natural Rubber											
2064-11								270/122					Neoprene											
2064-12								510/231					Neoprene											
2064-13								770/349					Neoprene											
2064-14								1170/530					Neoprene											
2064-15								2100/952					Neoprene											
2065-1								4.88 (124)					1.063 (27)	1.25 (31.8)	1.07 (27.2)	3.38 (85.0)	2.47 (62.7)	2 lb 14 oz (1305)	1140/517	1 1/4"	1.000"	8	900	Natural Rubber
2065-2																			1930/875					Natural Rubber
2065-3																			2580/1170					Natural Rubber
2065-4																			3540/1605					Natural Rubber
2065-5																			4560/2068					Natural Rubber
2065-11	1140/517	Neoprene																						
2065-12	1930/875	Neoprene																						
2065-13	2580/1170	Neoprene																						
2065-14	3540/1605	Neoprene																						
2065-15	4560/2068	Neoprene																						

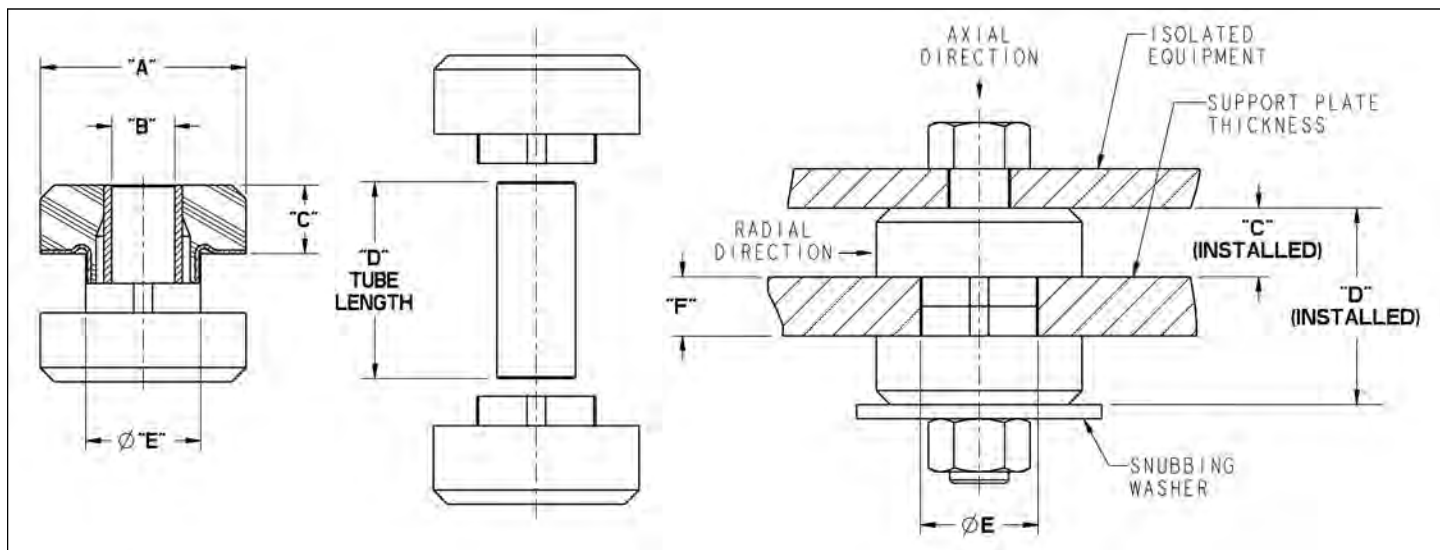

Bushing Series: 2061—2065

Dimension and Load Range Specifications

***The use of a snubbing washer is required to ensure proper static and dynamic loading of the isolator and retention of suspended equipment under severe shock environments.**

Snubbing washers are ordered by separate part numbers as shown in the table below.

Part #	O.D	I.D	Thickness	Snubbing Washer Part #
2061	1.56	.391	.090	SW-1560-0391-0090-SZ
2062	2.13	.532	.134	SW-2130-0532-0134-SZ
2063	2.81	.657	.188	SW-2810-0657-0188-SZ
2064	3.88	.938	.250	SW-3880-0938-0250-SZ
2065	5.25	1.063	.375	SW-5250-1063-0375-SZ

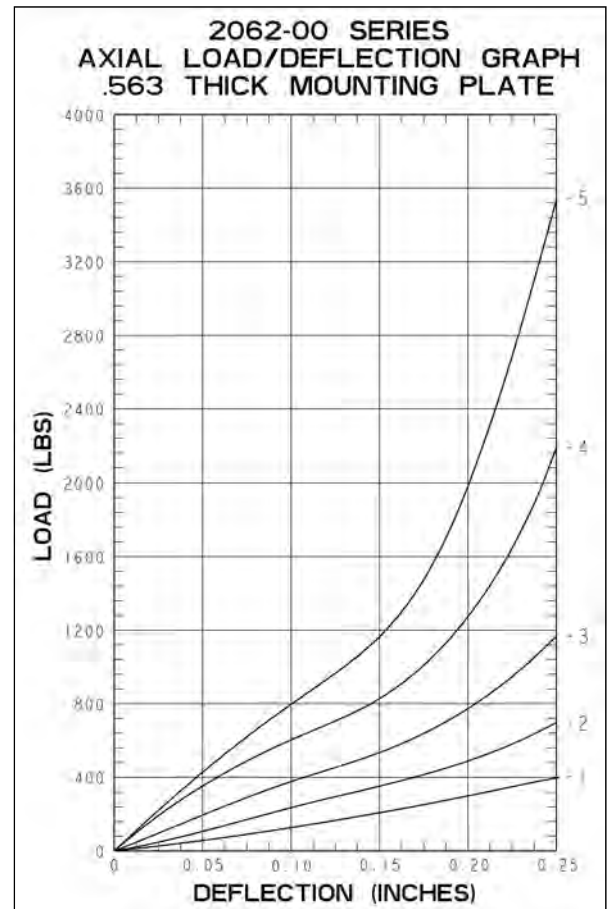
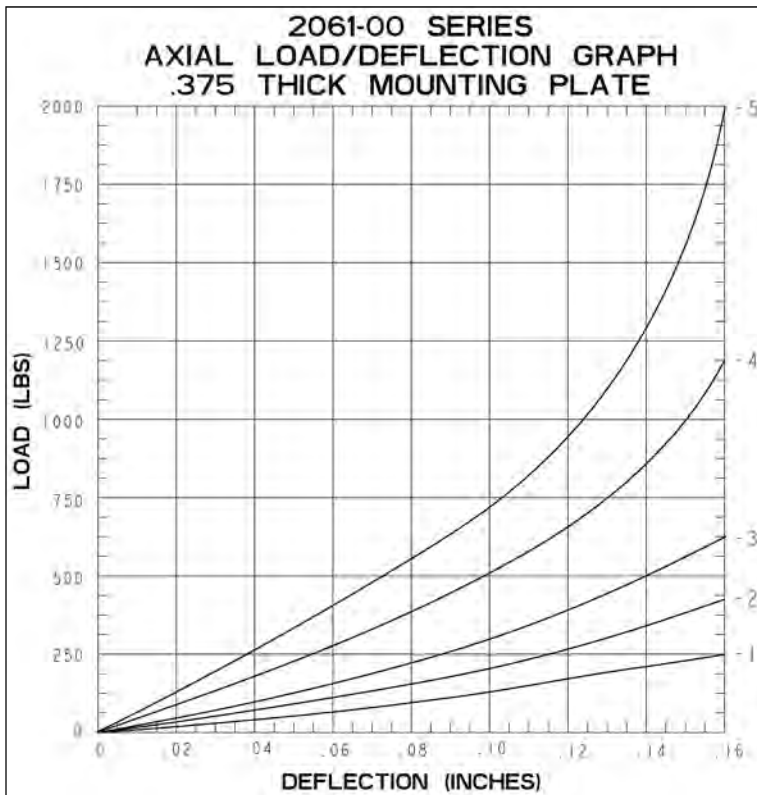

N

Bushing Series: 2061—2065

Dimension and Load Range Specifications

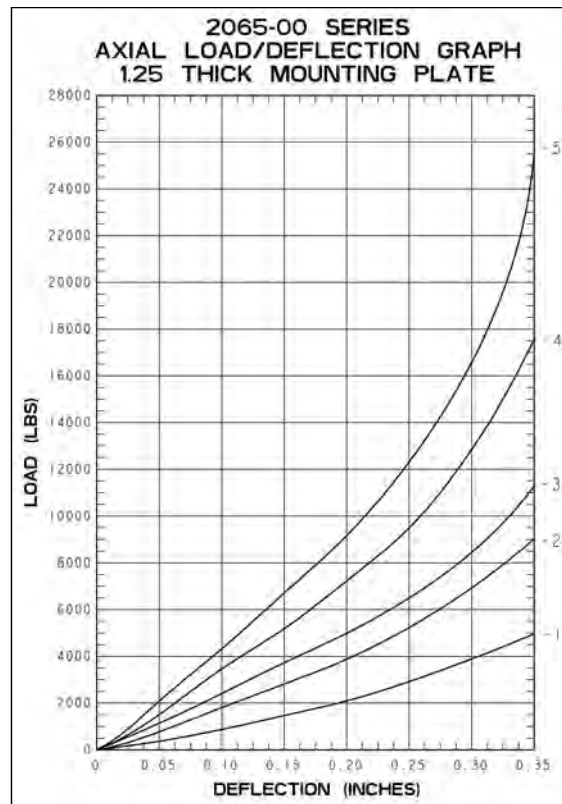
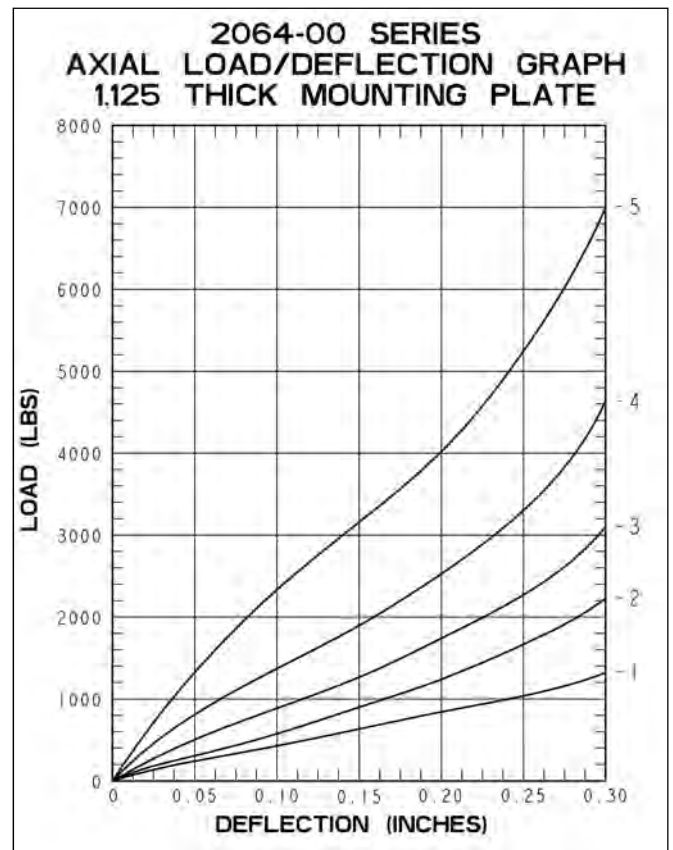
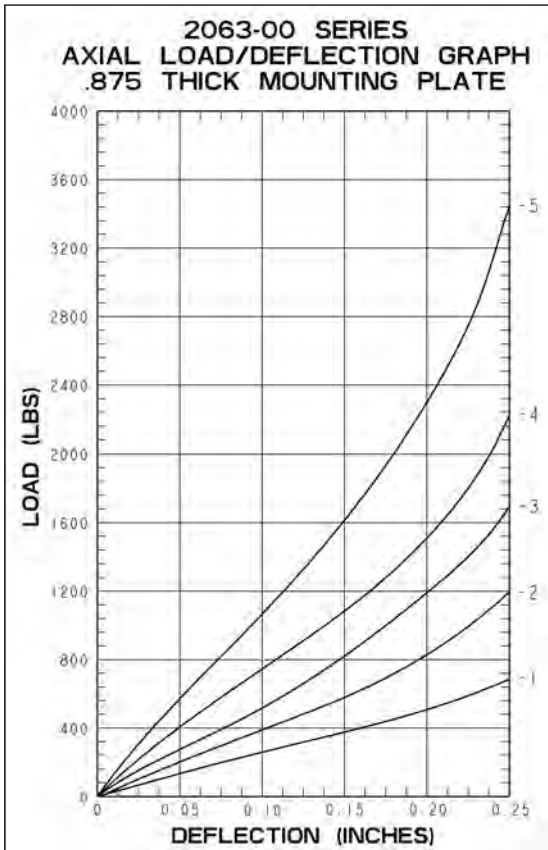

CAN-STYLE MOUNT SERIES

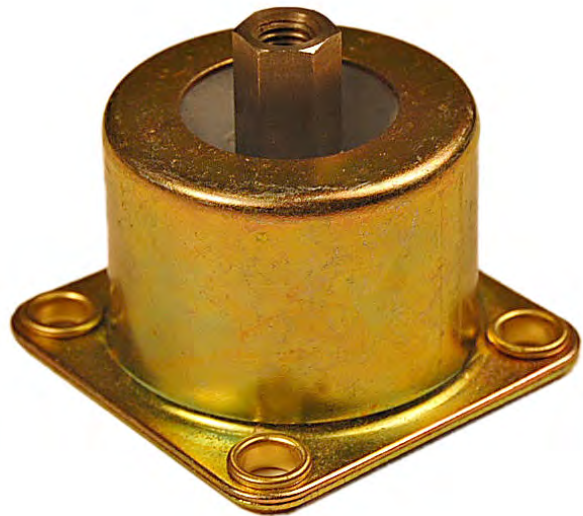

Can-Style Mount Series

A compact, all-attitude isolator for mounting equipment for aircraft, shipboard and vehicular applications



Applications

- Military electronics (shipboard, vehicle)
- Electronics for rotary wing and propeller driven aircraft
- Avionics & electronics
- Racking and tray systems

Shock and Vibe

- Provides excellent vibration attenuation at frequencies above 40 hertz
- Survives a 30g, 11 millisecond half-sine shock pulse

Attributes

- Fail-safe design, all attitude isolator
- Axial to radial stiffness ratio 1:1
- Compact, low profile design
- Easy to install
- High damped silicone
- Isolates equipment under 5g's sustained

Load Range

- 1766 = 4 load ratings available up to 5 lbs.
- 1767 = 3 load ratings available up to 20 lbs.
- 1769 = 3 load ratings available up to 80 lbs.

Specifications

- Natural Frequency — 15-40 Hertz
- Transmissibility at resonance — 4.0 max.
- Resilient Element — Hi-damped silicone
- Standard materials — varies with model
- Weight—1766 = 1.07 oz. 1767 = 1.21 oz. 1769 = 1.33 oz.

Elastomeric Data

- Hi-Damp Silicone operating temperature range is -67F to +300°F (-55°C to +150°C)
- Passes MIL-E-5400 requirements for resistance to ozone, humidity, salt spray and fungus
- Passes MIL-S-901 lightweight Grade B high impact shock test requirements

Can-Style Mount Series: 1766

Dimension and Performance Characteristics

Part #	Maximum Axial Compression	Load (lbs.) Radial	Axial Natural Frequency (hz)	Transmissibility at Resonance	Standard Material	Standard Elastomer	Mounting Hole Diameter "A"
1766-1	1	1	24	4:1	Steel & Aluminum	Hi-Damp Silicone	Ø .162
1766-2	2	2	22	4:1	Steel & Aluminum	Hi-Damp Silicone	Ø .162
1766-3	3	3	23	4:1	Steel & Aluminum	Hi-Damp Silicone	Ø .162
1766-5	5	5	22	4:1	Steel & Aluminum	Hi-Damp Silicone	Ø .162

Optional Black Anodize Finish Available

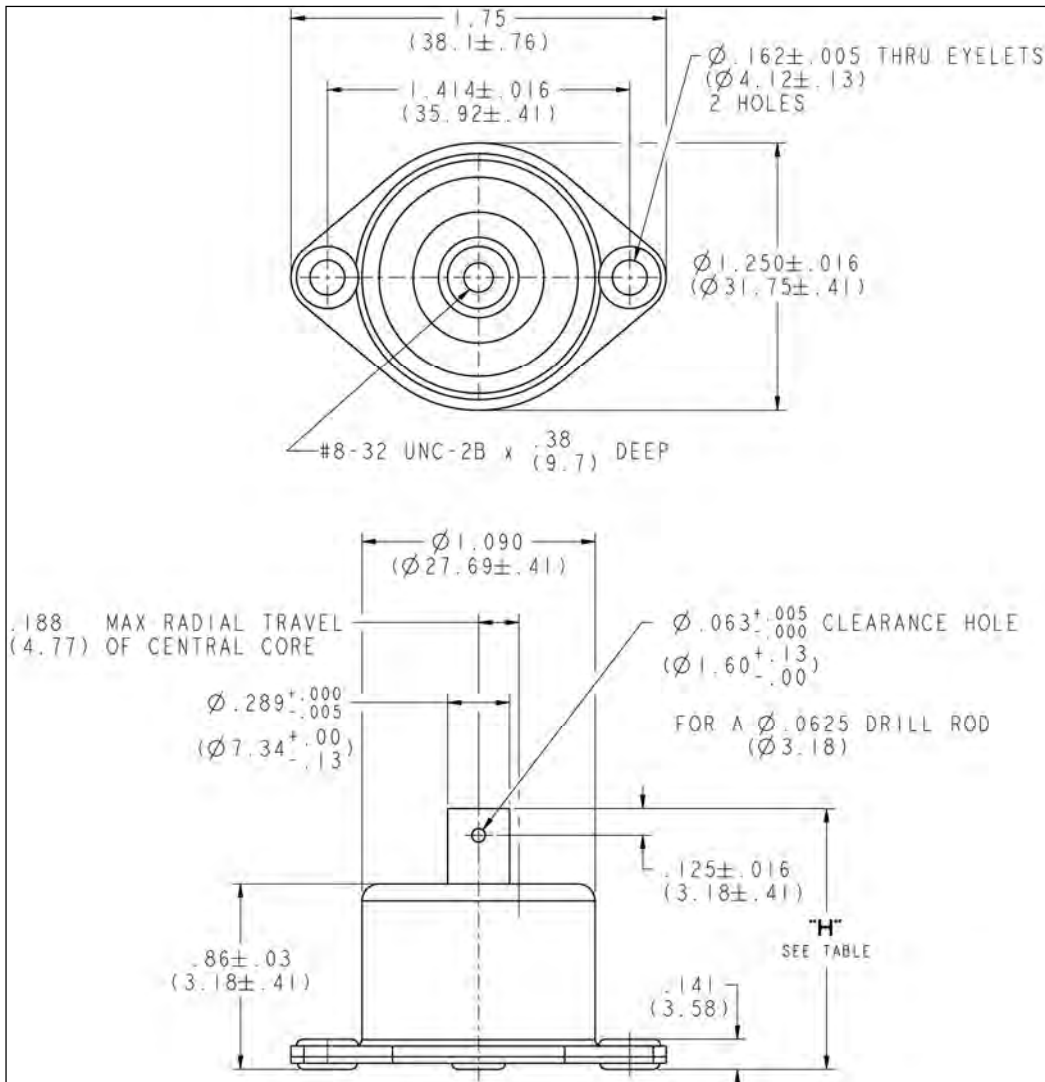

1766 "H" Dimension	
Compressed	.91
Free Height	1.22
Max. Extended	1.56



Can-Style Mount Series: 1766

Dimension and Performance Characteristics

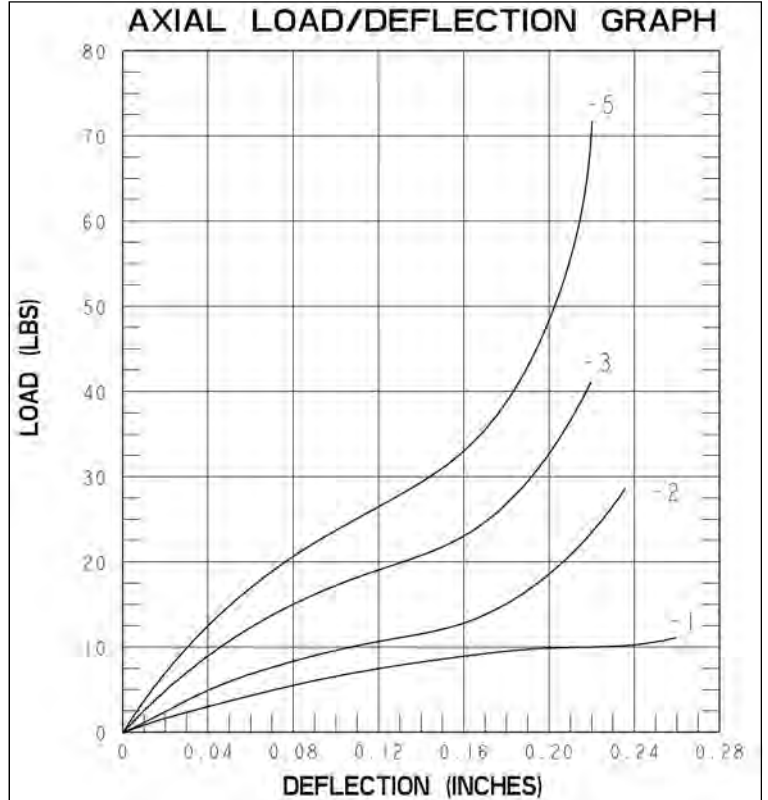
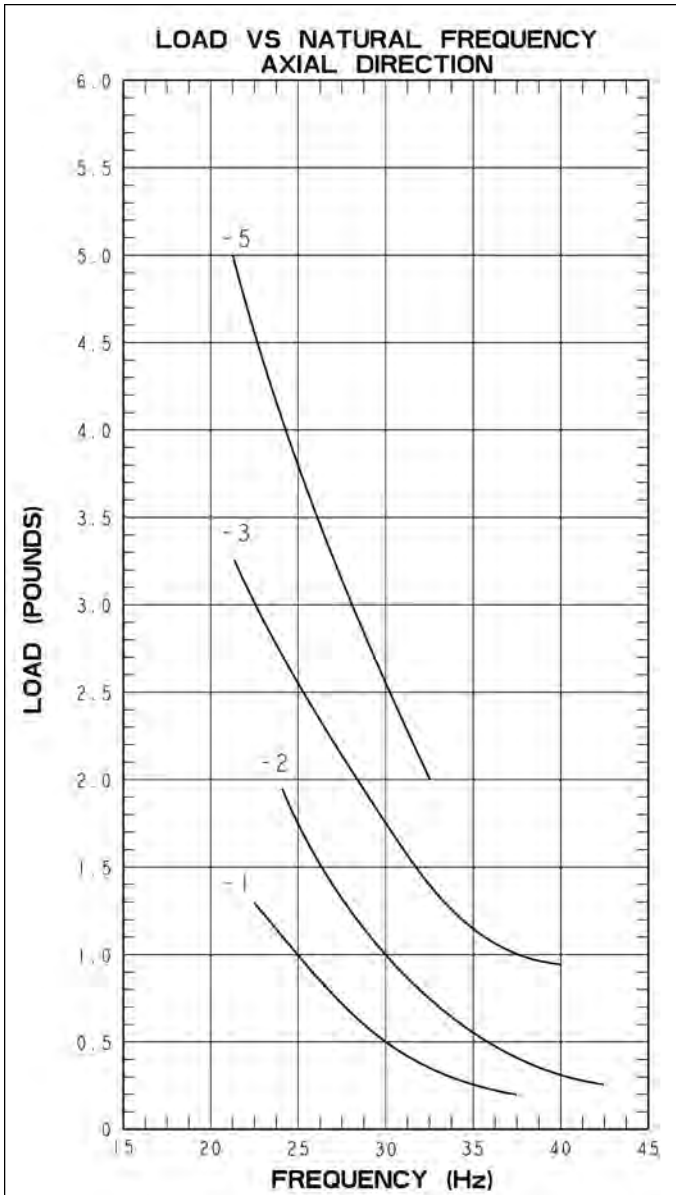

Can-Style Mount Series: 1767

Dimension and Performance Characteristics

Part #	Maximum Axial Compression	Load (lbs.) Radial	Axial Natural Frequency (hz)	Transmissibility at Resonance	Standard Material	Standard Elastomer	Mounting Hole Diameter "A"
1767-1	10	10	22	4:1	Steel	Hi-Damp Silicone	Ø .224
1767-1S	10	10	22	4:1	Stainless Steel	Hi-Damp Silicone	Ø .192
1767-2	15	15	20	4:1	Steel	Hi-Damp Silicone	Ø .224
1767-2S	15	15	20	4:1	Stainless Steel	Hi-Damp Silicone	Ø .192
1767-3	20	20	21	4:1	Steel	Hi-Damp Silicone	Ø .224
1767-3S	20	20	21	4:1	Stainless Steel	Hi-Damp Silicone	Ø .192

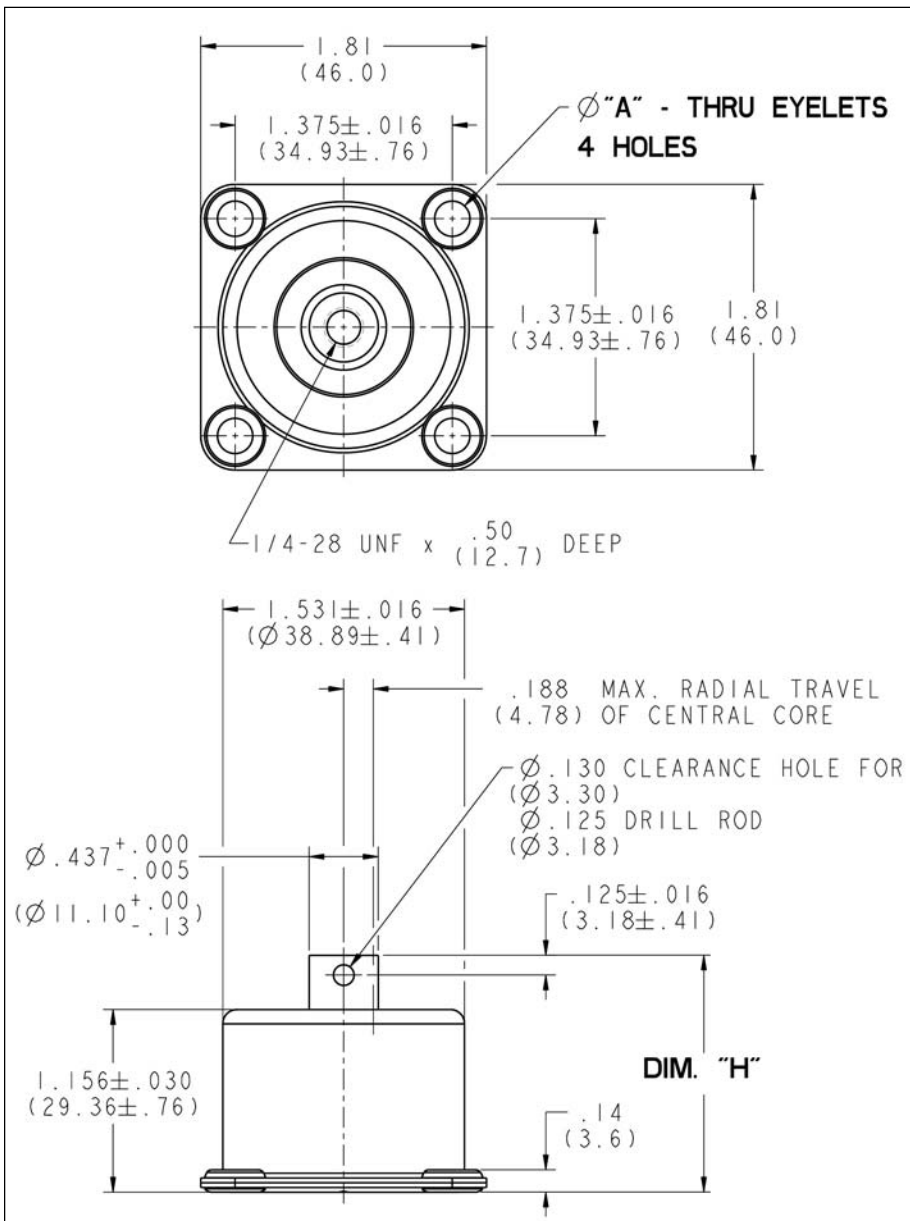

1767 "H" Dimension	
Compressed	1.19
Free Height	1.50
Max. Extended	1.88



Can-Style Mount Series: 1767

Dimension and Performance Characteristics

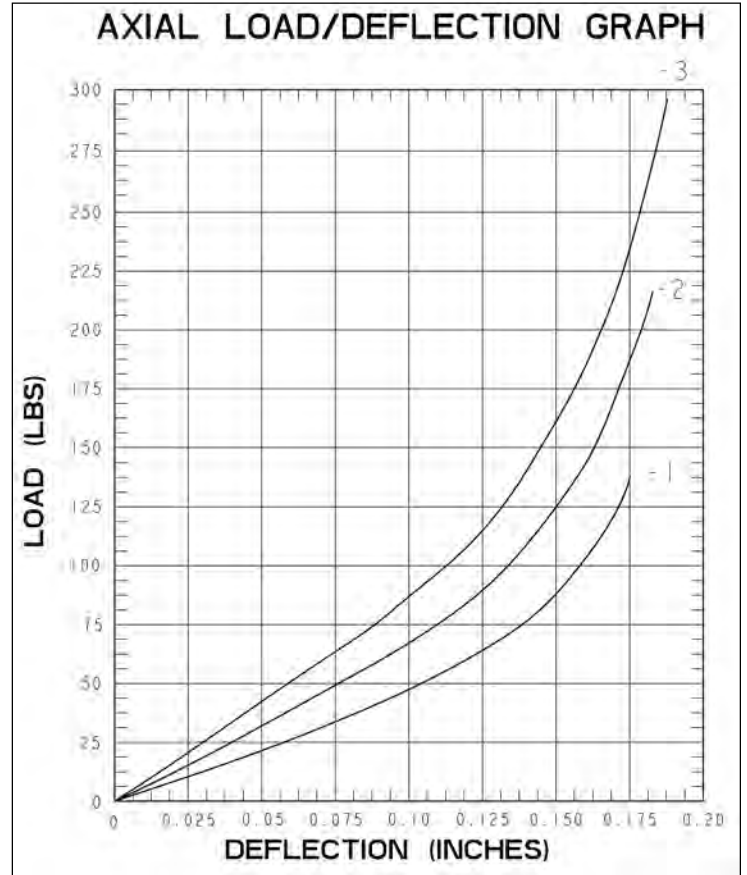
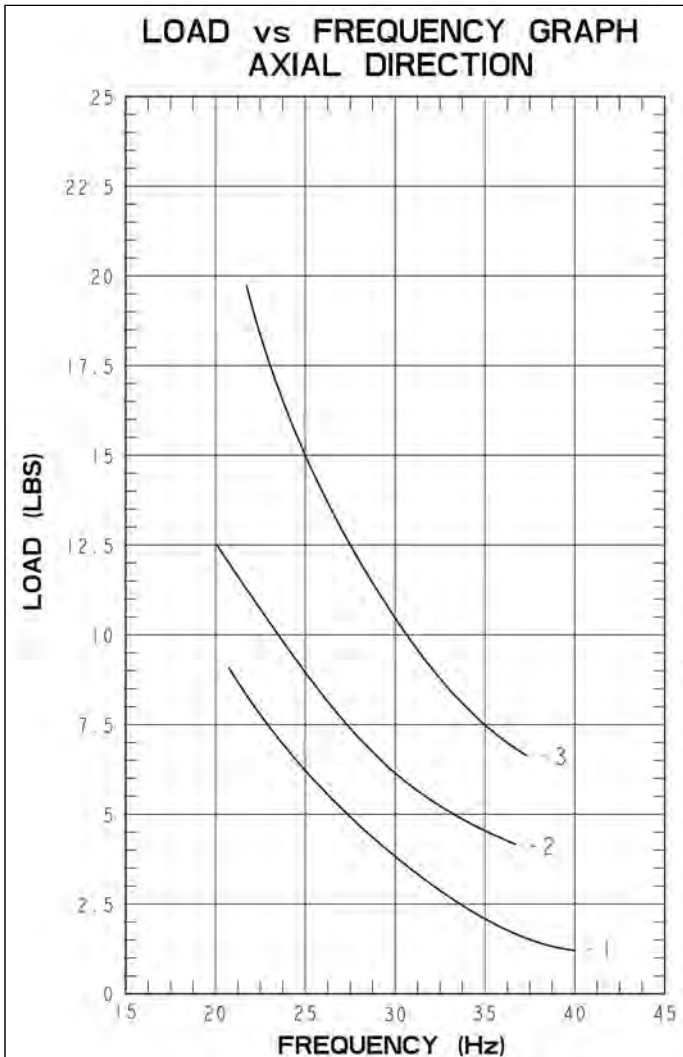

Can-Style Mount Series: 1769

Dimension and Performance Characteristics

Part #	Maximum Axial Compression	Load (lbs.) Radial	Axial Natural Frequency (hz)	Transmissibility at Resonance	Standard Material	Standard Elastomer	Mounting Hole Diameter "A"
1769-1	35	35	18	4:1	Steel & Aluminum	Hi-Damp Silicone	Ø .224
1769-2	50	50	17	4:1	Steel & Aluminum	Hi-Damp Silicone	Ø .224
1769-3	80	80	18	4:1	Steel & Aluminum	Hi-Damp Silicone	Ø .224

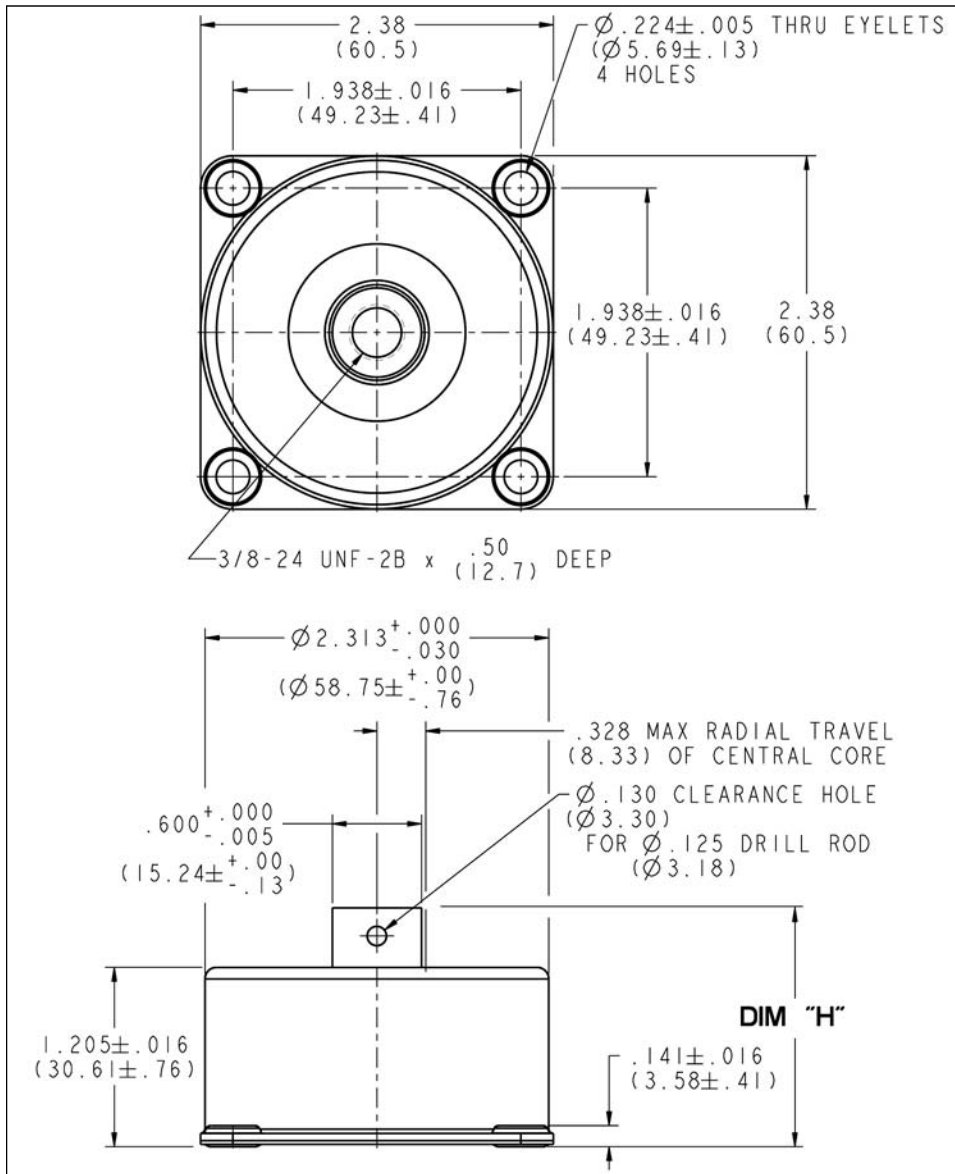

1769 "H" Dimension	
Compressed	1.25
Free Height	1.62
Max. Extended	1.94



Can-Style Mount Series: 1769

Dimension and Performance Characteristics

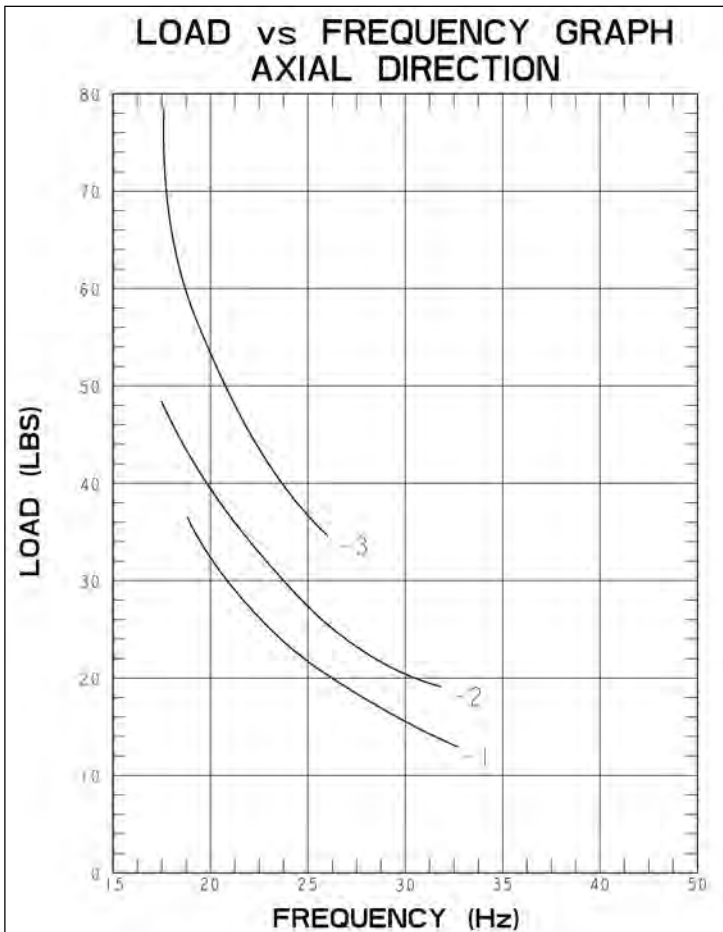
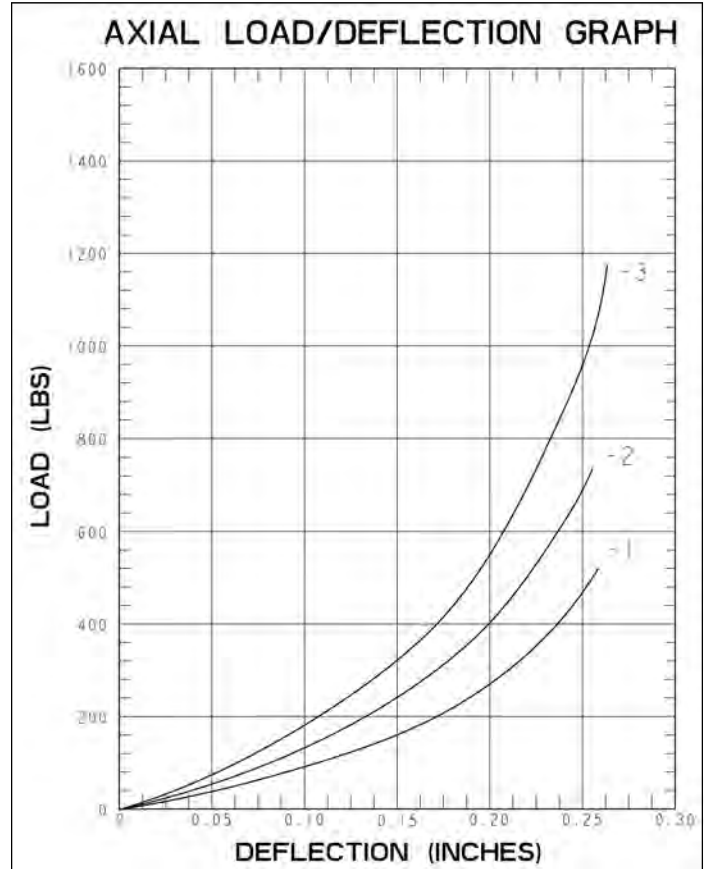

AIR MOUNT SERIES

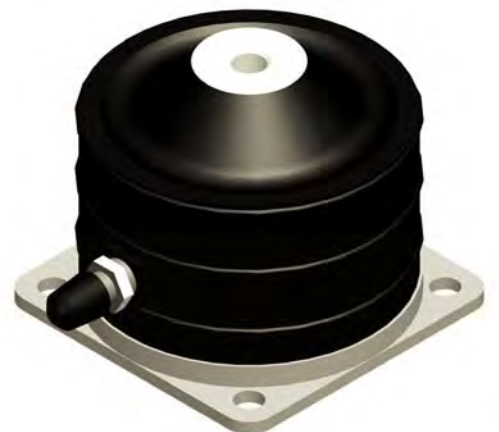

English Air Isolator Series

Low frequency, high load capacity air mounts designed for high shock and vibration application



Attributes

- Air-cushioned isolators
- High deflection
- Reinforced wall construction
- Supports load with no air pressure
- Low profile

Applications

- CMM Machinery
- Large industrial machinery
- Laboratory equipment
- Presses
- Compressors

Benefits

- Low maintenance
- Extends machinery life
- Combined resiliency and air prevents high static deflection, drift and permanent set
- High load capacity

Specifications

- Natural Frequency — 3-5 Hertz
- Transmissibility at Resonance — 8:1
- Resilient Element — Neoprene
- Metal Structure — Steel Aluminum

Elastomeric Data

- Neoprene has an operating temperature range of -40°F to 200°F (-40°C to +93°C) and is resistant to oil and ozone

Air Isolator Series: 3001-3008

Dimension and Performance Characteristics

Part Number	Max Load (lbs.)	Part Dimensions (in.)										Weight (lbs.)
		A ± 0.02	B ± 0.01	C	D	E ± 0.02	F ± 0.02	G ± 0.05	H ± 0.01	J ± 0.01	T ± 0.010	
3001-00	100	3.00	2.38	.375-16 UNC-2B	0.47	0.28	2.88	2.50	1.00	0.50	0.125	1
3002-00	300	4.19	3.50	.500-13 UNC-2B	0.53	0.28	4.14	2.45	2.06	0.54	0.125	1.5
3003-00	600	5.12	4.25	.500-13 UNC-2B	0.53	0.29	4.99	3.50	2.38	0.56	0.125	3.25
3004-00	1200	6.88	6.00	.500-13 UNC-2B	0.53	0.29	6.74	3.50	3.75	0.56	0.125	5.5
3005-00	2400	10.00	8.50	.625-11 UNC-2B	0.75	0.56	9.66	3.50	4.75	0.56	0.188	13
3006-00	4800	13.50	12.00	.625-11 UNC-2B	0.75	0.56	13.31	3.50	7.50	0.56	0.188	26
3007-00	9600	18.50	16.00	1.000-14 UNS-2B	0.88	0.81	18.44	3.50	11.60	0.56	0.250	57
3008-00	19200	24.00	20.00	1.000-14 UNS-2B	0.88	0.81	24	3.50	15.75	0.56	0.250	100

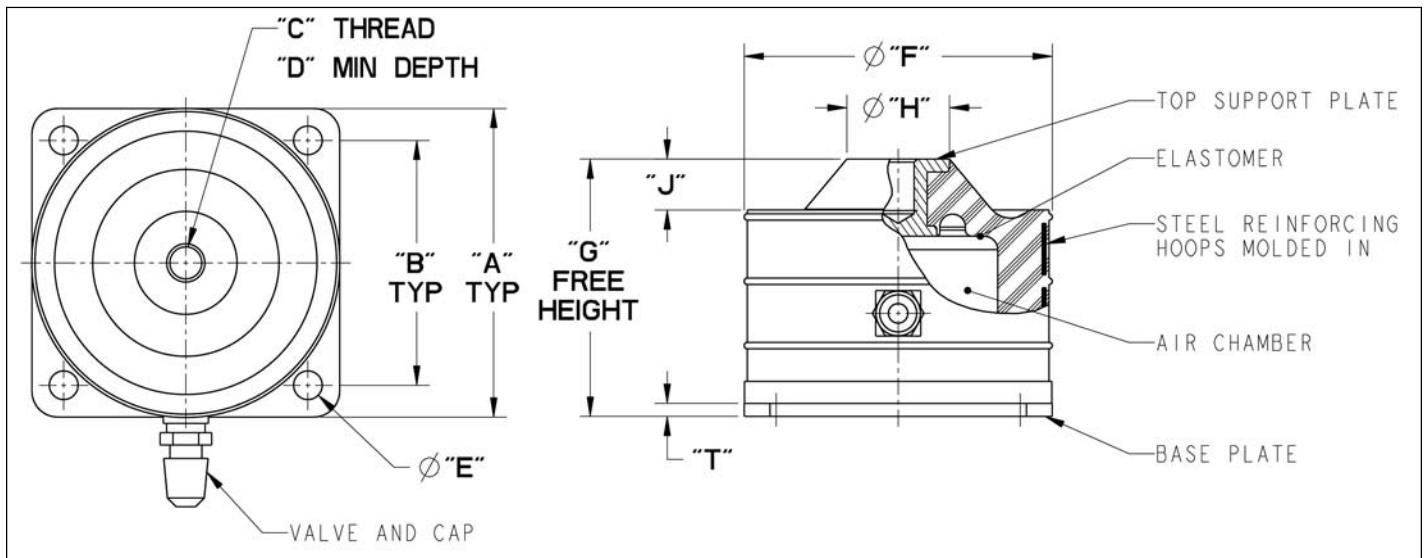

P

Metric Air Isolator Series

Low frequency, high load capacity air mounts designed for high shock and vibration application



Applications

- Air compressors
- CMM machinery
- Forging hammers
- Industrial equipment, tools and machinery

Benefits

- Low maintenance
- Extends machinery life
- Combined resiliency and air prevents high static deflection, drift or permanent set
- Wide load range available

Attributes

- Air-cushioned isolation
- High deflection
- Neoprene padded top and bottom base
- Heavy wall construction

Specifications

- Natural Frequency — 3-5 Hertz
- Transmissibility at Resonance — 8:1
- Resilient Element — Neoprene
- Metal Structure — Carbon Steel

Elastomeric Data

- Neoprene has an operating temperature range of -40°F to 200°F (-40°C to $+93^{\circ}\text{C}$) and is resistant to oil and ozone

Metric Air Isolator Series: 3009-3015

Dimension and Performance Characteristics

Part Number	Load Range (lbs.)	Part Dimensions (in.)							Thread
		A	B	C	D	E	F	G	
3009-00	100-200	125	100	12	50	100	100	80	M10
3010-00	200-400	125	100	12	60	100	100	80	M12
3011-00	400-800	160	125	12	90	138	100	80	M12
3012-00	800-1500	200	160	12	110	164	100	80	M12
3013-00	1400-2500	250	200	14	150	212	100	80	M16
3014-00	2400-4500	350	300	14	240	314	100	80	M16
3015-00	4000-7500	450	400	14	330	412	100	80	M16

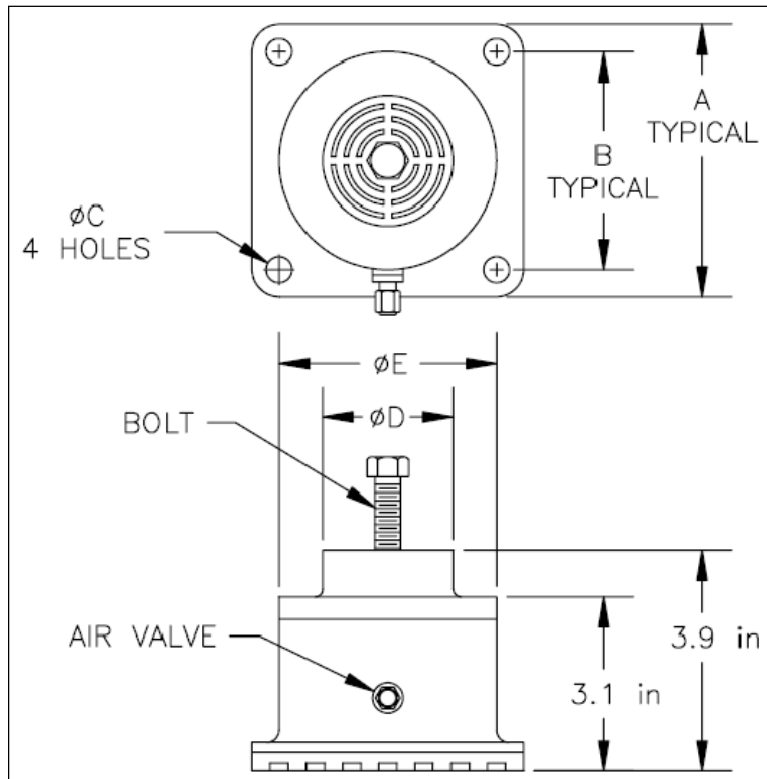

P

CUSHYFLEX MOUNT SERIES



CushyFlex Mount Series

2182, 2183 & 2184



Attributes

- Fail-safe
- Compact, low profile design
- Zinc plated construction
- Easy to install

Applications

- Marine engines
- Marine generators
- Off-highway equipment
- Construction equipment
- Large motors, pumps, compressors

Benefits

- Rugged construction
- All steel construction

Load Range

- 2182 = 4 load ratings to 270 lbs.
- 2183 = 4 load ratings to 990 lbs.
- 2184 = 4 load ratings to 2200 lbs.

Specifications

- Natural frequency—8-10 Hertz at rated load
- Transmissibility at resonance — 10 max (Neoprene)
- Standard material — zinc plated steel

Elastomeric Data

- Neoprene has an operating temperature range of -40°F to 200°F (-40°C to $+93^{\circ}\text{C}$), and is used where oil immersion is present



CushyFlex Mount Series: 2182

Dimension and Performance Characteristics

Part Number	Maximum Load (lbs.)	Durometer	Color Code
2182-1	110	Neoprene—45	Red
2182-2	145	Neoprene—55	Orange
2182-3	220	Neoprene—65	Yellow
2182-4	270	Neoprene—75	White

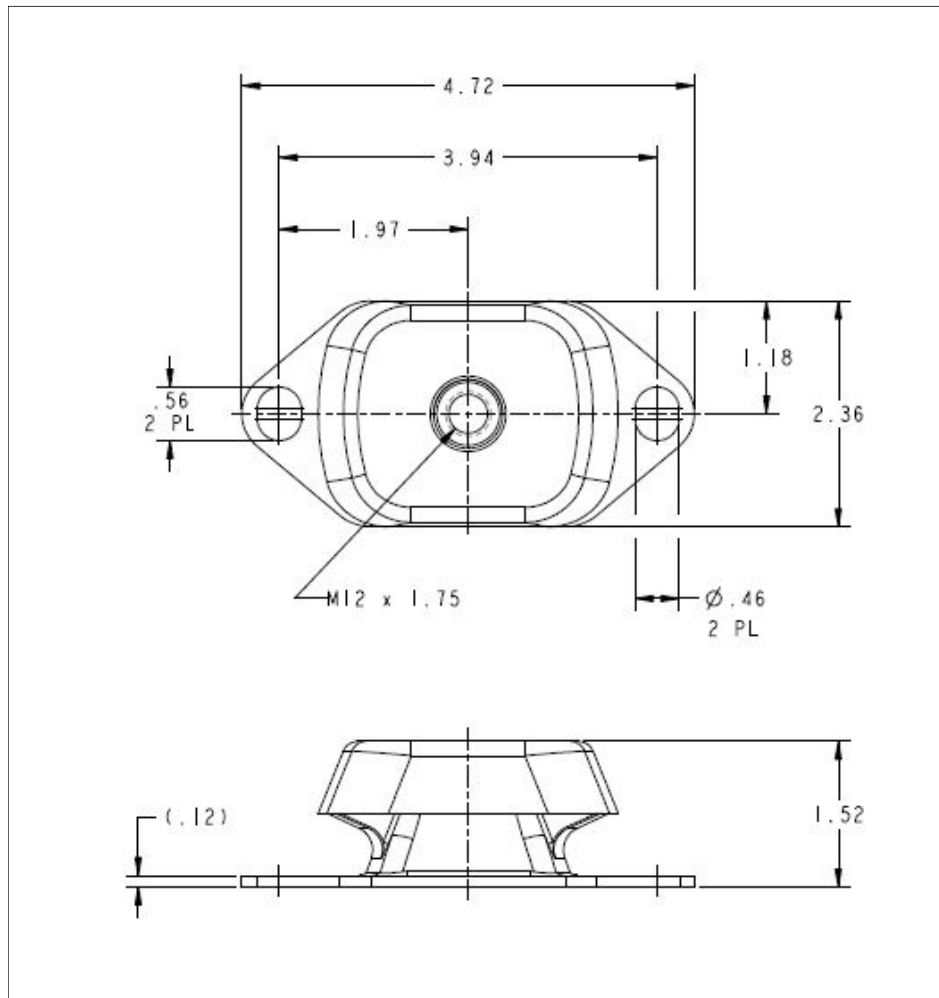

CushyFlex Mount Series: 2182

Dimension and Performance Characteristics

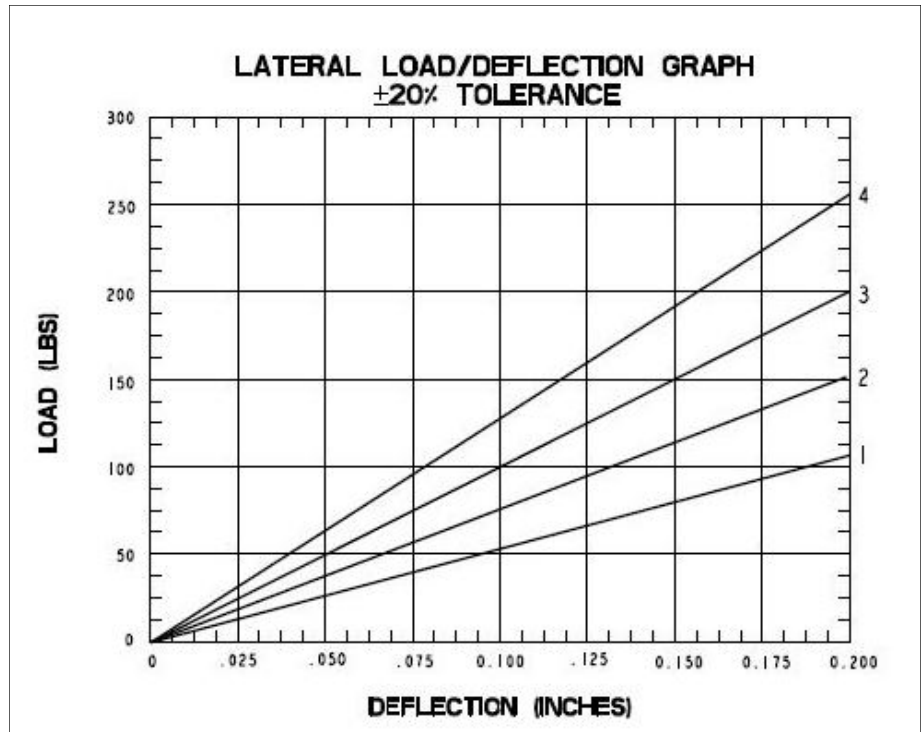
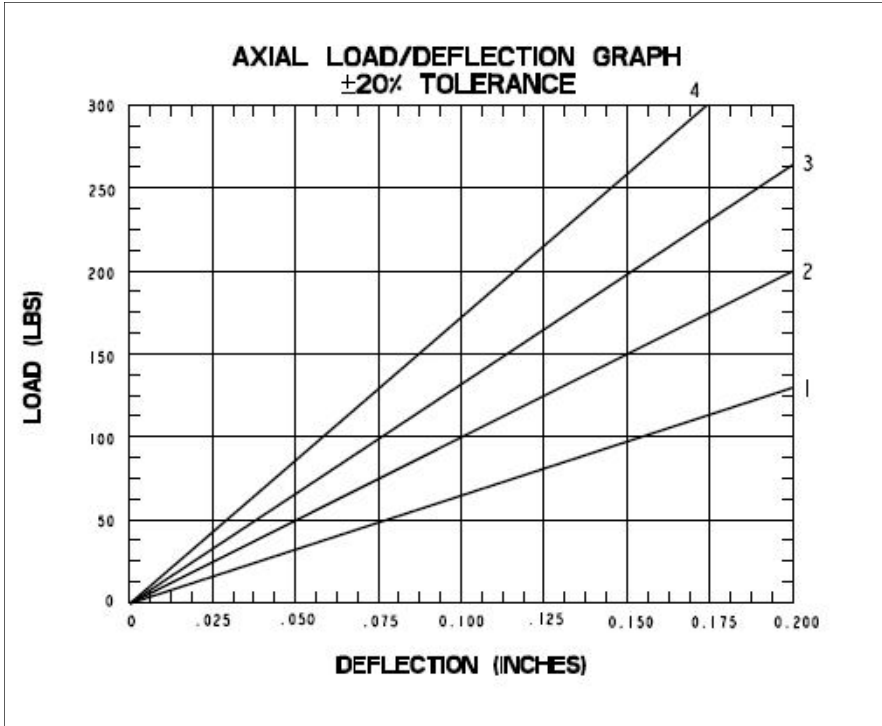

Q

CushyFlex Mount Series: 2182

Dimension and Performance Characteristics

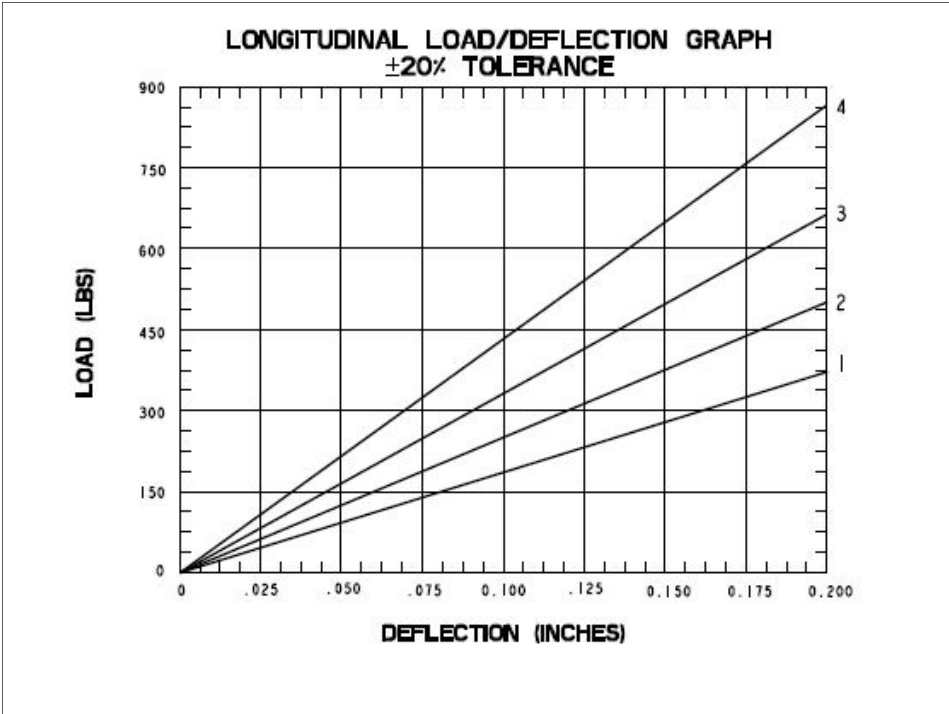

CushyFlex Mount Series: 2183

Dimension and Performance Characteristics

Part Number	Maximum Load (lbs.)	Durometer	Color Code
2183-1	330	Neoprene—45	Red
2183-2	465	Neoprene—55	Orange
2183-3	660	Neoprene—65	Yellow
2183-4	990	Neoprene—75	White

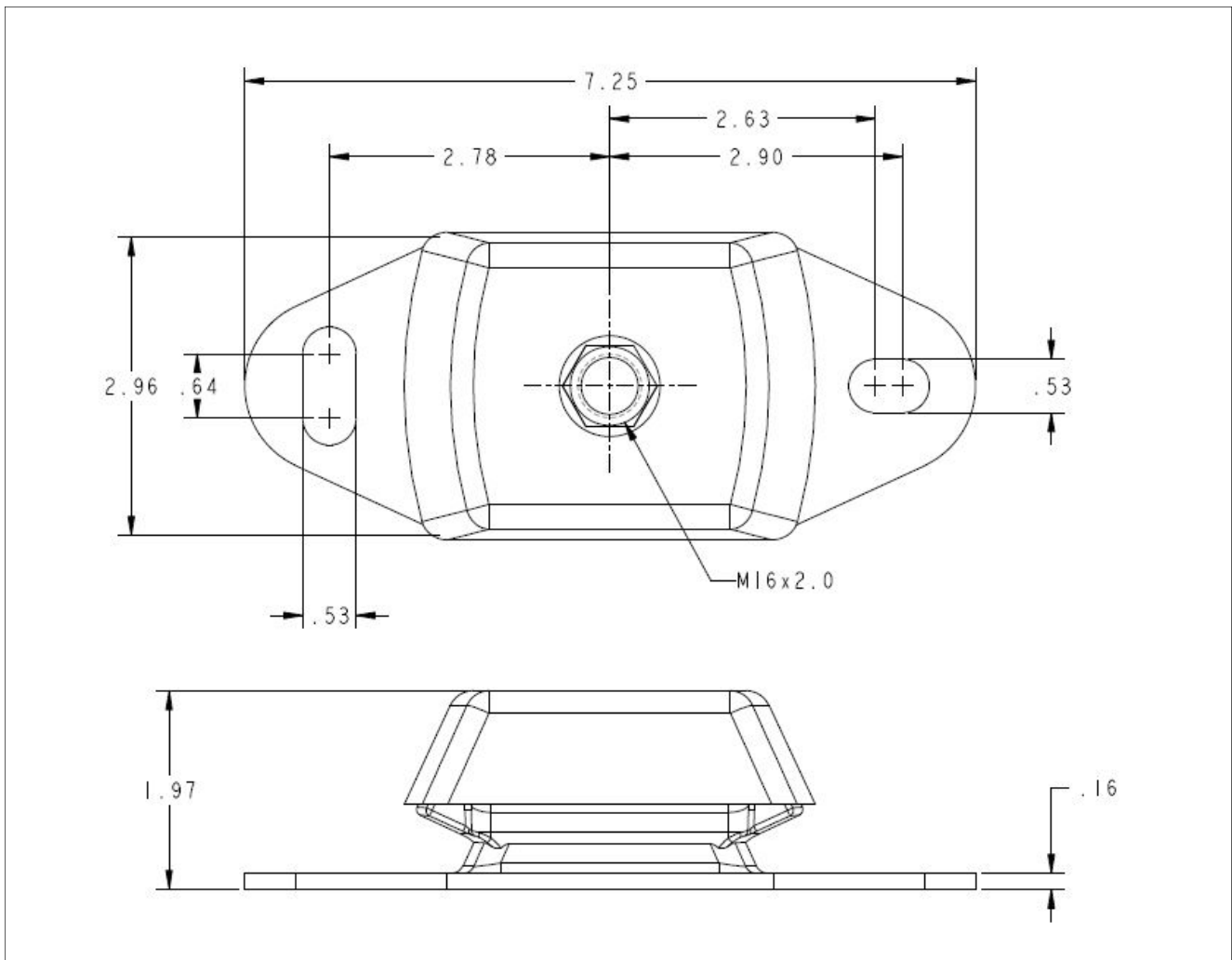

Q

CushyFlex Mount Series: 2183

Dimension and Performance Characteristics

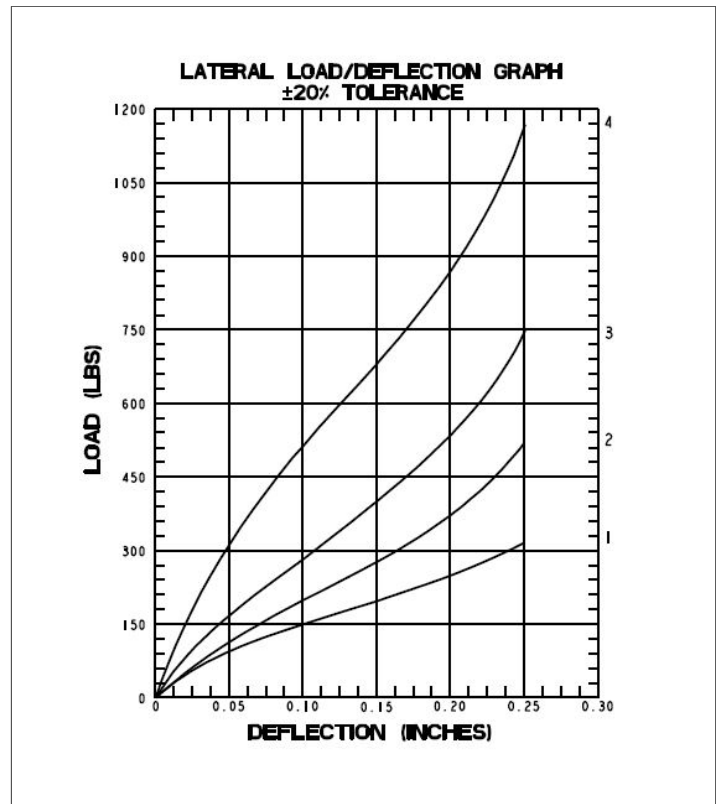
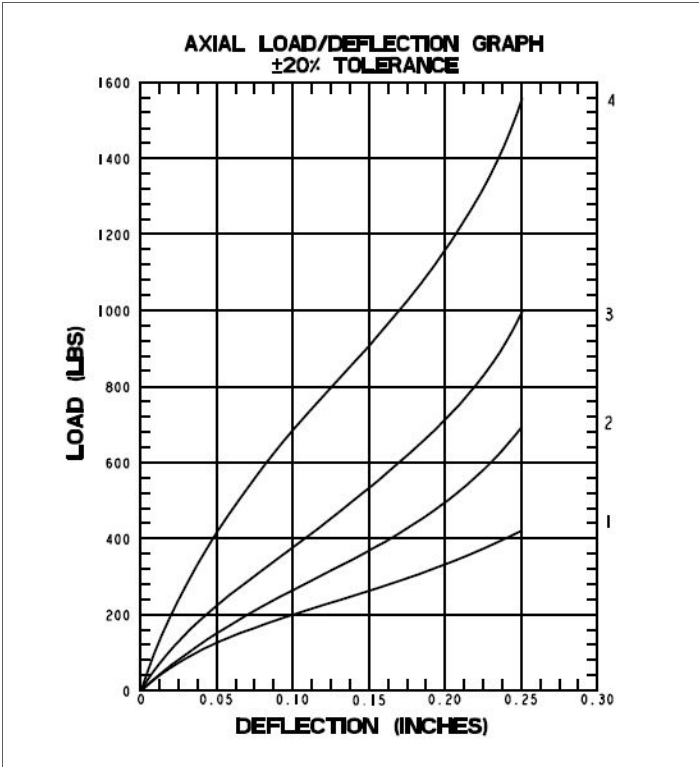

CushyFlex Mount Series: 2183

Dimension and Performance Characteristics

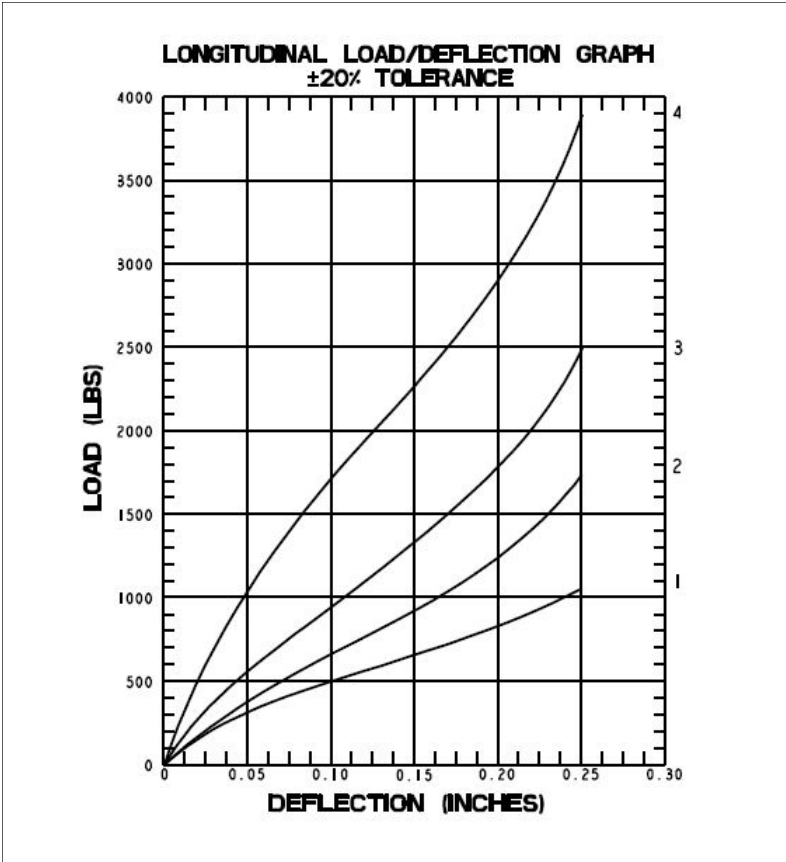

CushyFlex Mount Series: 2184

Dimension and Performance Characteristics

Part Number	Maximum Load (lbs.)	Durometer	Color Code
2184-1	770	Neoprene 45	Red
2184-2	1145	Neoprene 55	Orange
2184-3	1550	Neoprene 65	Yellow
2184-4	2200	Neoprene 75	White

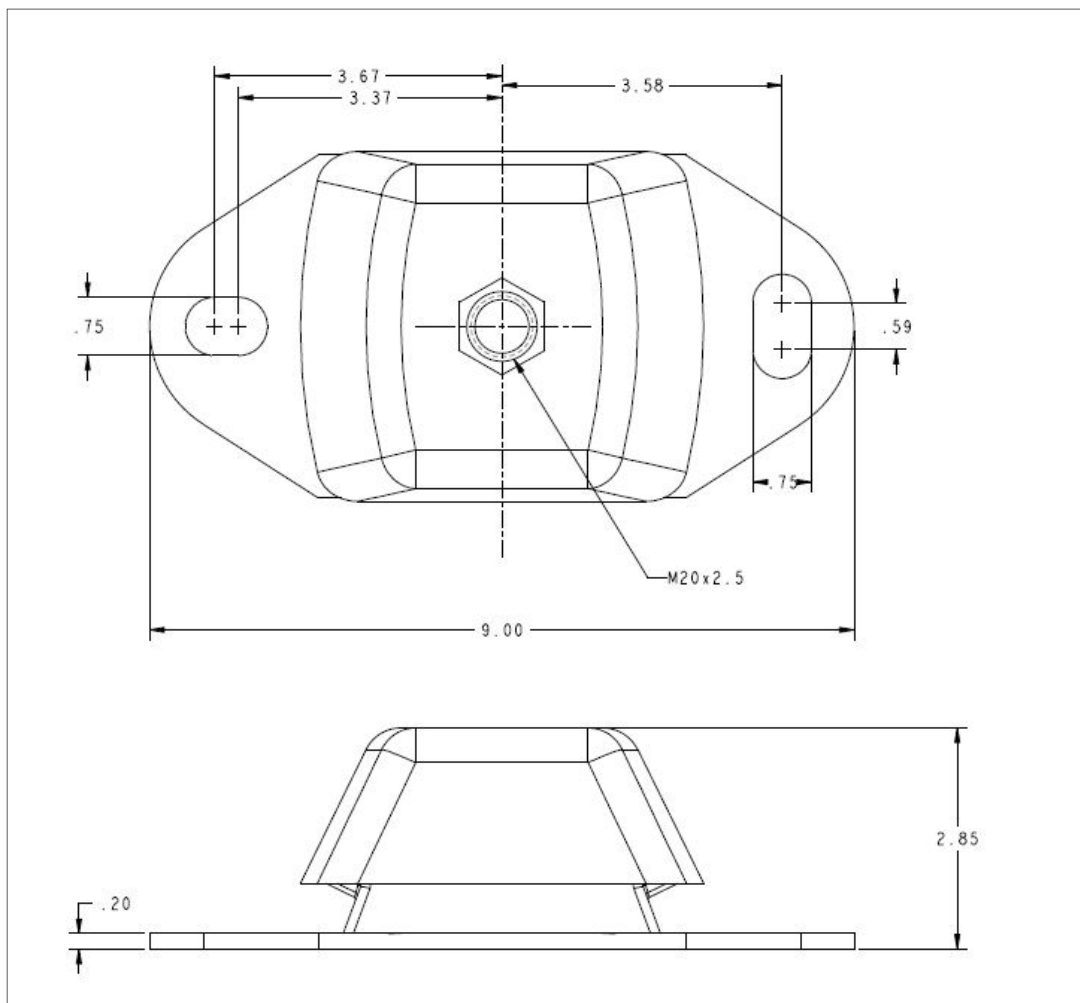

CushyFlex Mount Series: 2184

Dimension and Performance Characteristics

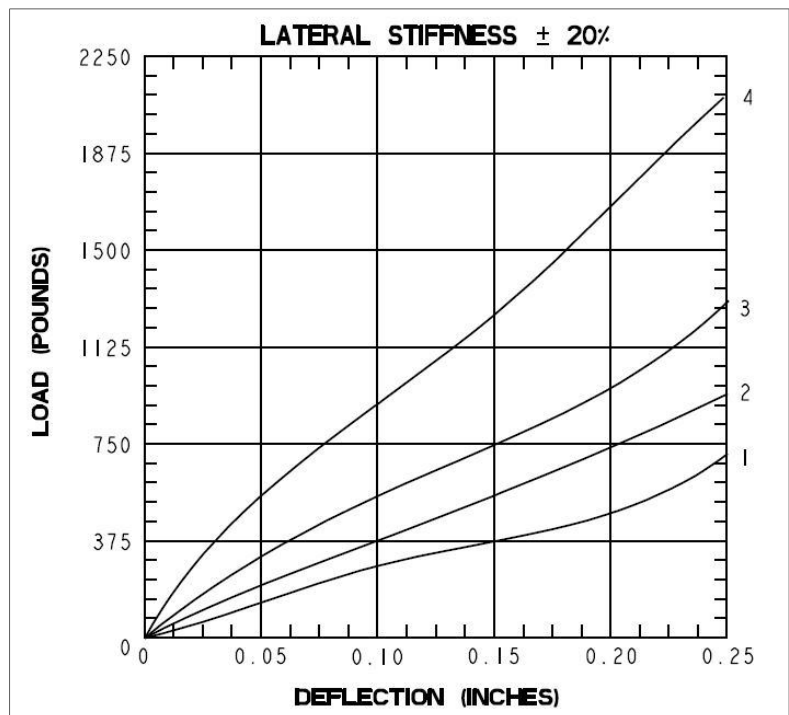
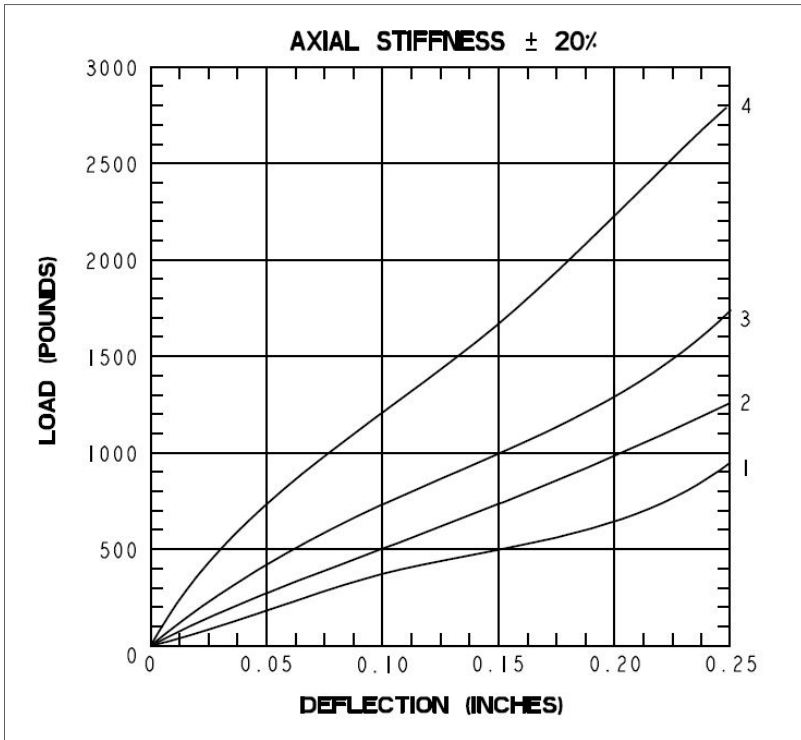

Q

CushyFlex Mount Series: 2184

Dimension and Performance Characteristics

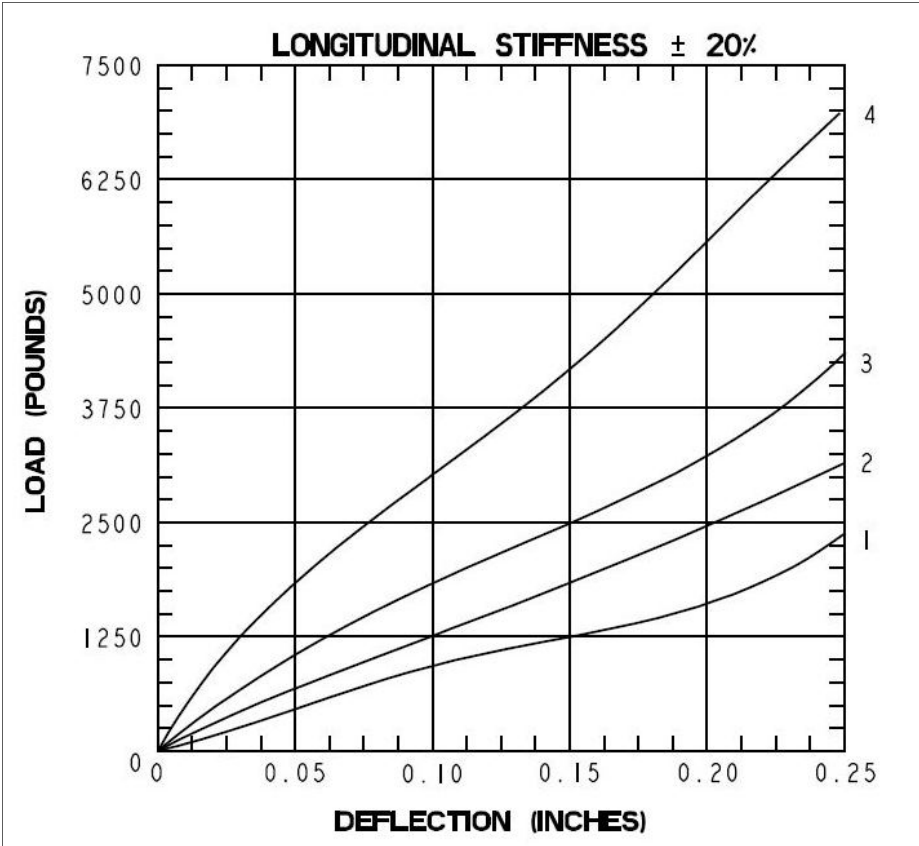

SANDWICH MOUNT SERIES



Sandwich Mount Series

2205, 2206, 2207

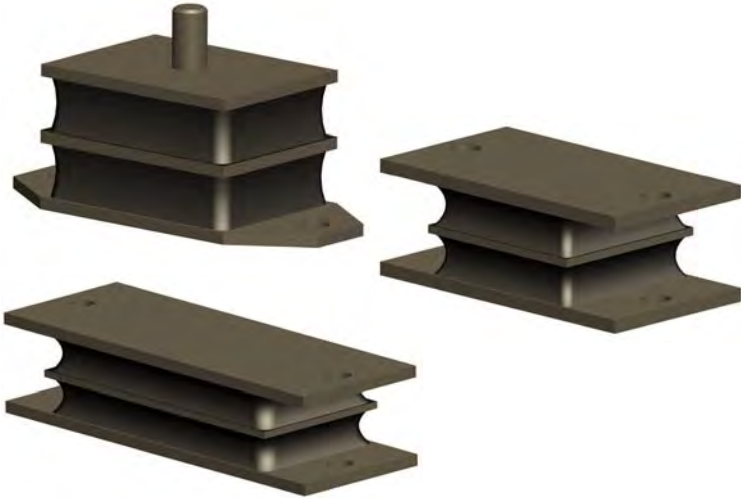

Applications

- Truck, bus, marine engines
- Generators, HVAC equipment
- Pumps and Compressors

Benefits

- Easy to install
- Low cost construction
- Mounted both in compression or shear

Attributes

- Rugged construction
- Compact design
- Linear load vs. deflection

Specifications

- Natural frequency -10-20 Hz
- Transmissibility at resonance - 10:1
- Resilient element - neoprene
- Standard materials - cold rolled steel
- Standard finish - zinc plated steel

Elastomeric Data

- Neoprene elastomer has an operating temperature range of -40F to +200°F (-40°C to +93°C) and is resistant to oil, most solvents and ozone
-

Sandwich Mount Series: 2205

Dimension and Performance Characteristics

Part Number	Load		Deflection	
	(lbs.)	(kgs.)	(inch)	(mm)
2205-1	210	95	.110	2.8
2205-2	298	135	.110	2.8
2205-3	441	200	.110	2.8
2205-4	684	310	.110	2.8
2205-5	772	350	.094	2.4

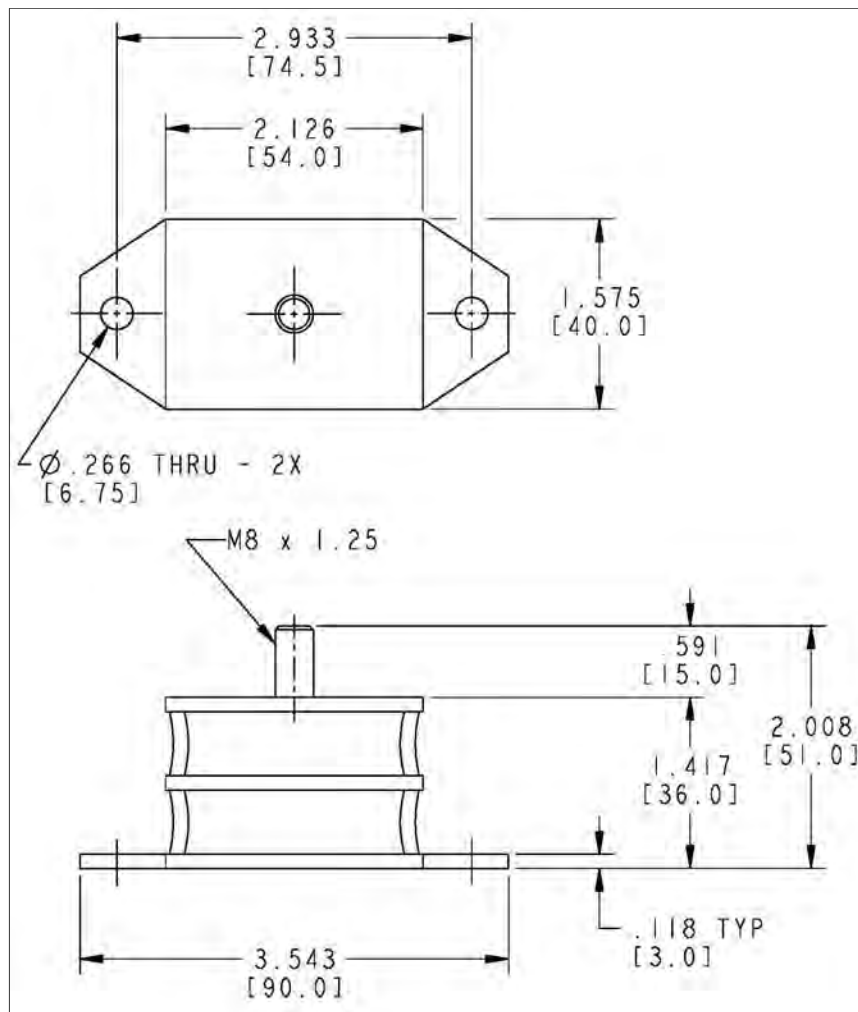

R

Sandwich Mount Series: 2205

Dimension and Performance Characteristics

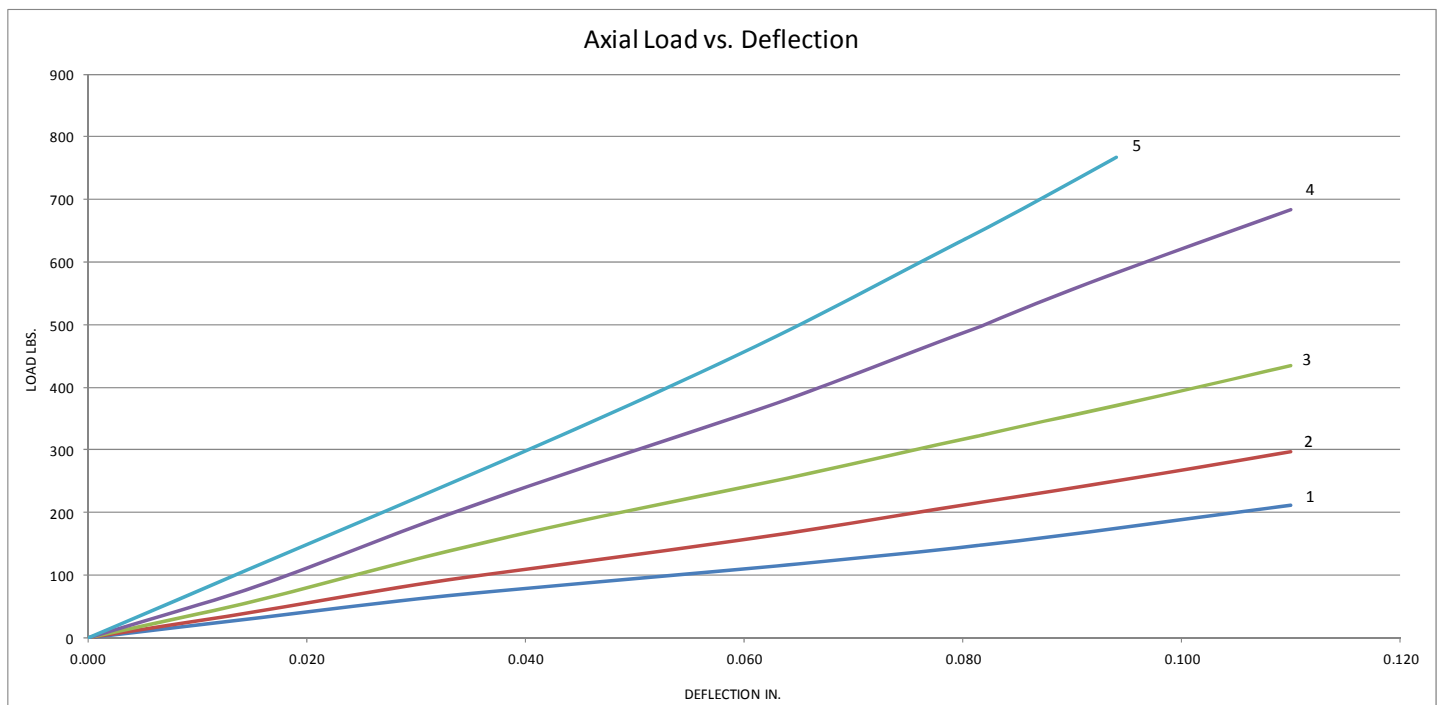
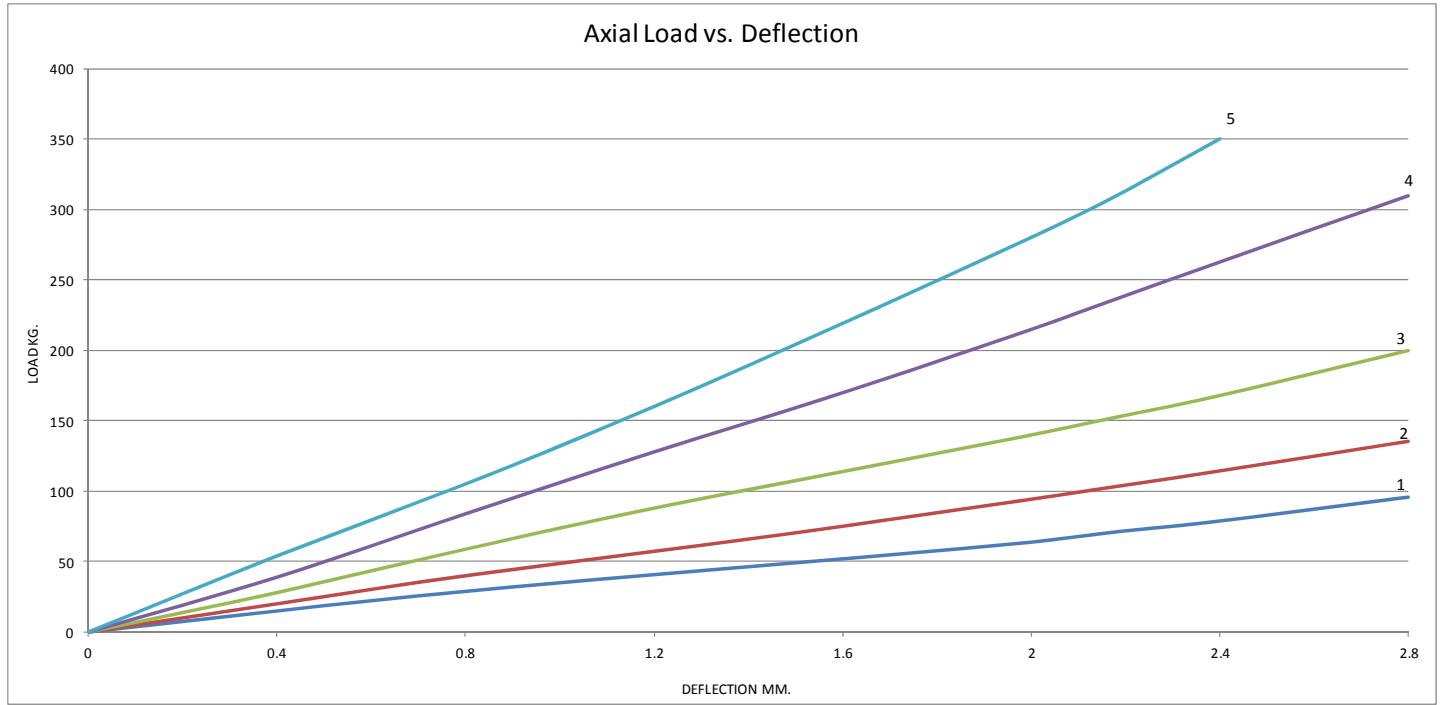

Sandwich Mount Series: 2206

Dimension and Performance Characteristics

Part Number	Load		Deflection	
	(lbs.)	(kgs)	(inch)	(mm)
2206-1	309	140	.118	3.0
2206-2	529	240	.118	3.0
2206-3	827	375	.118	3.0

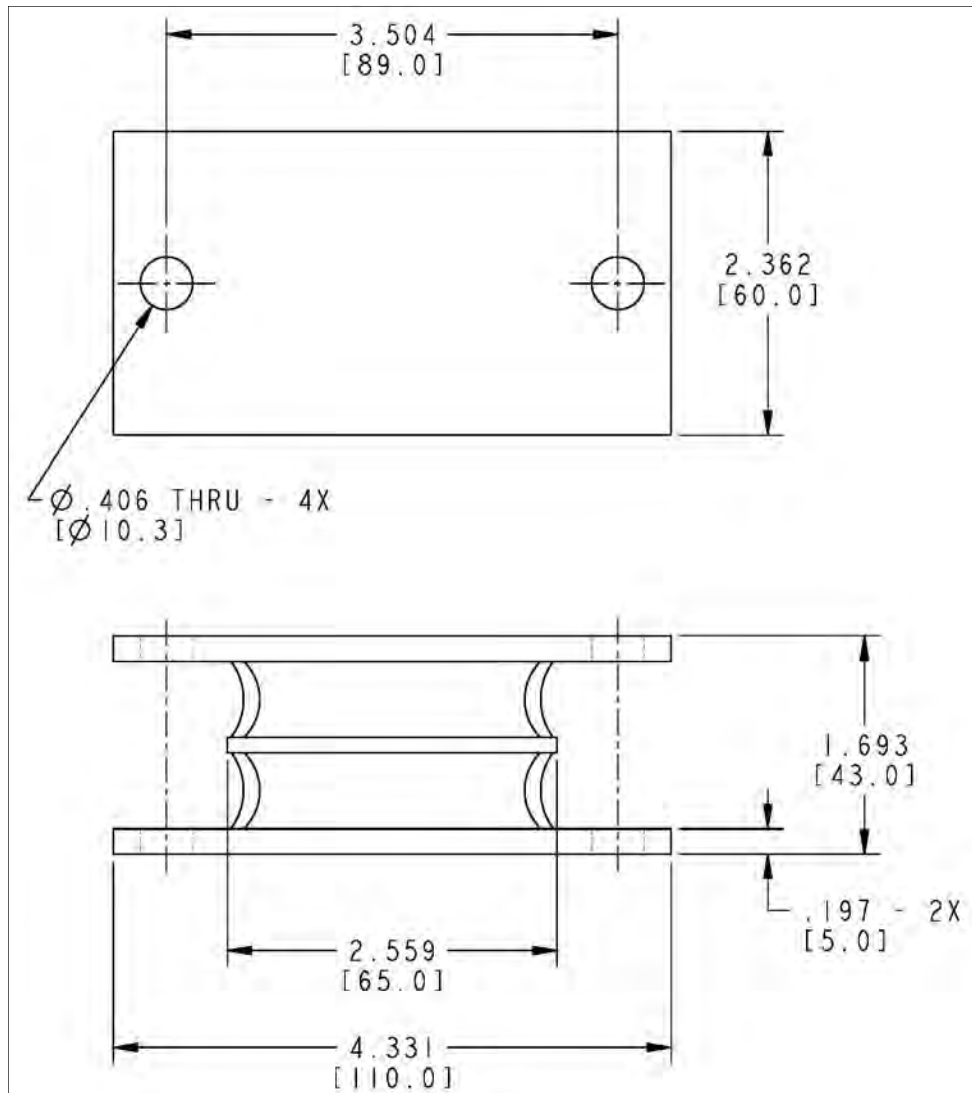

Sandwich Mount Series: 2206

Dimension and Performance Characteristics

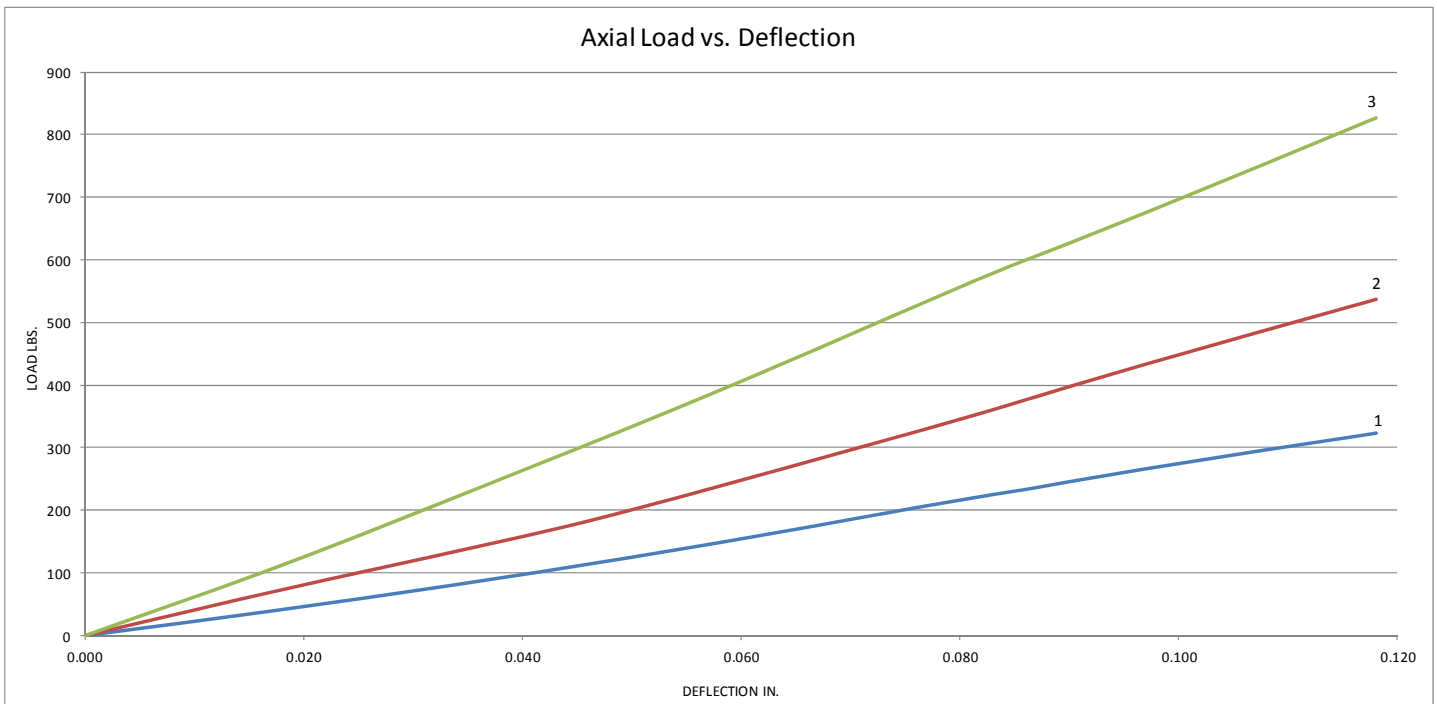
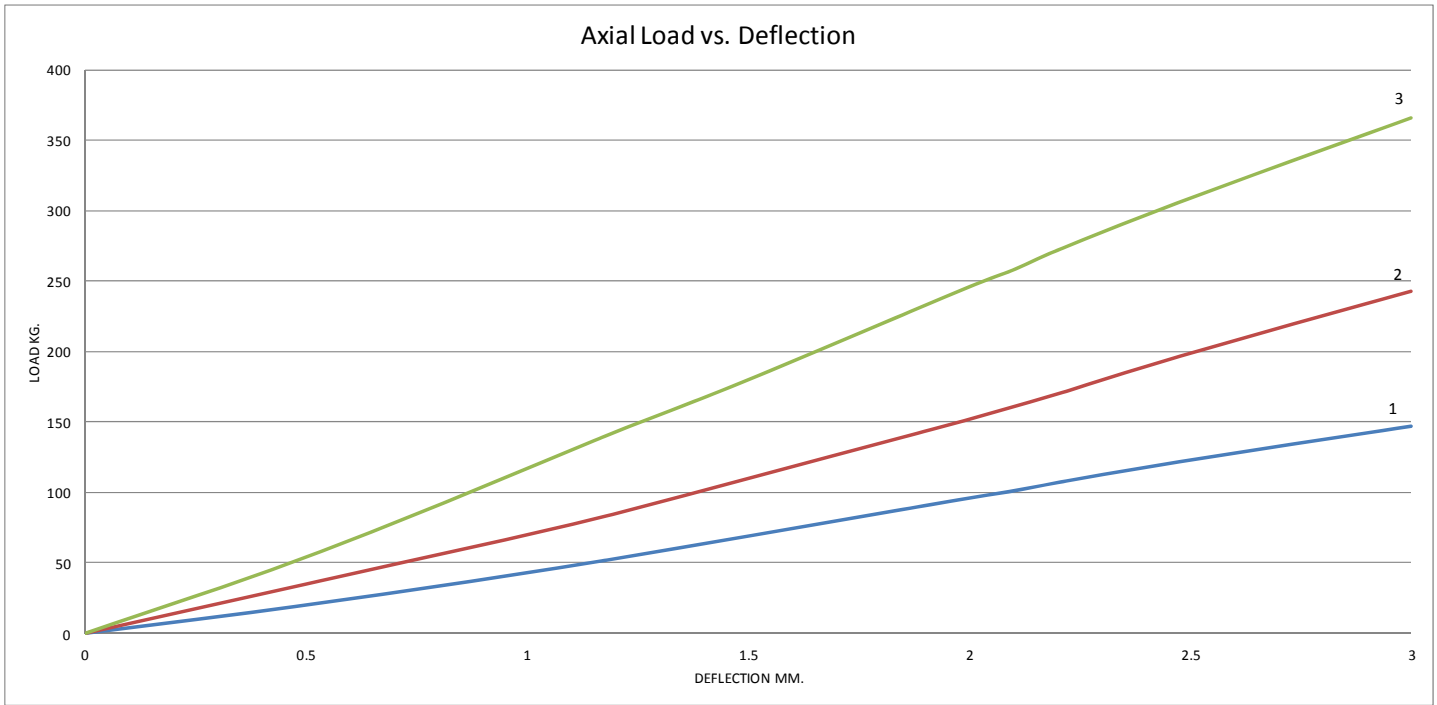

Sandwich Mount Series: 2207

Dimension and Performance Characteristics

Part Number	Load		Deflection	
	(lbs.)	(kgs)	(inch)	(mm)
2207-1	882	400	.118	3.0
2207-2	1345	610	.118	3.0
2207-3	1874	850	.110	2.8
2207-4	2205	1000	.087	2.2
2207-5	4190	1900	.079	2.0

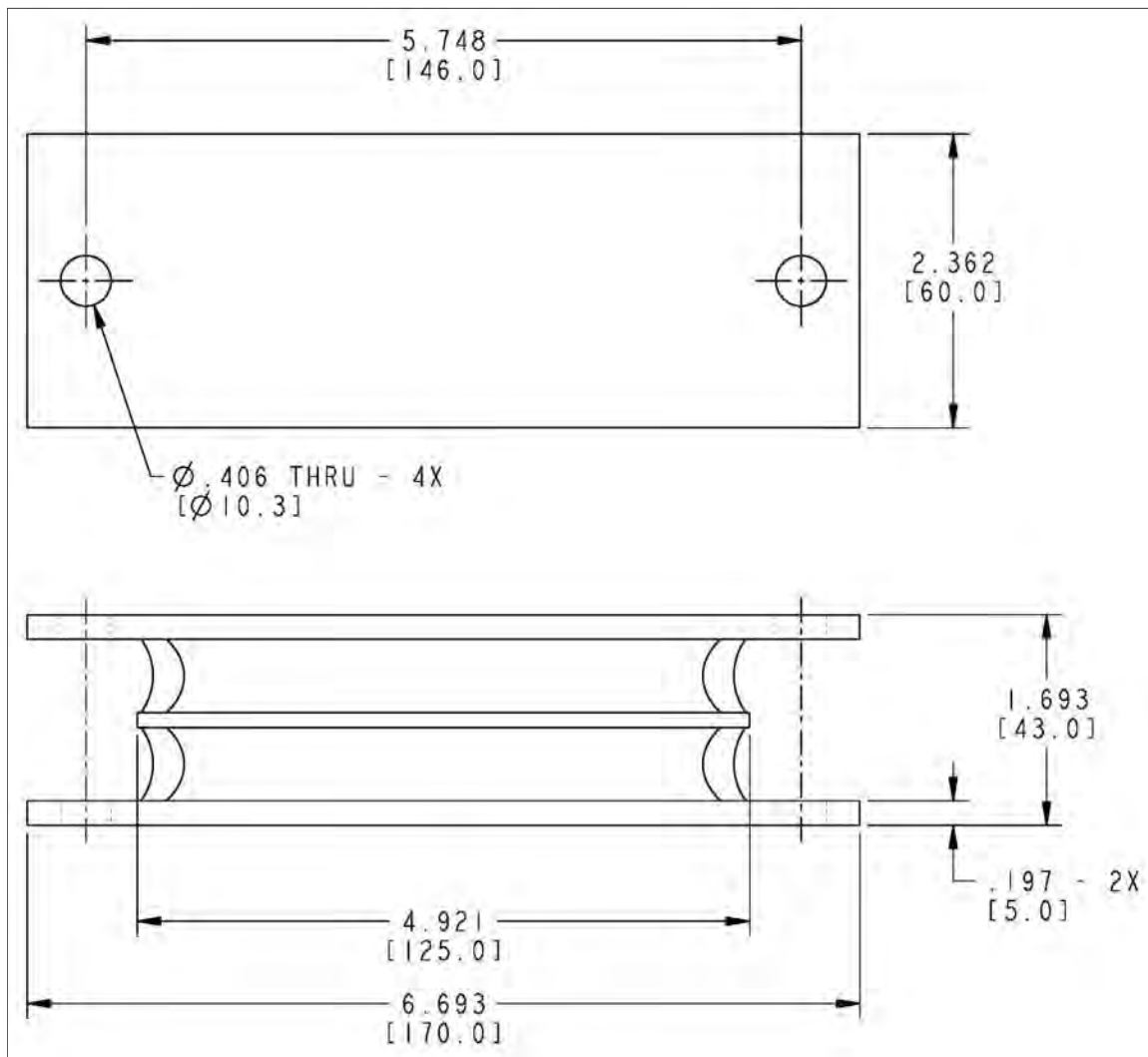

Sandwich Mount Series: 2207

Dimension and Performance Characteristics

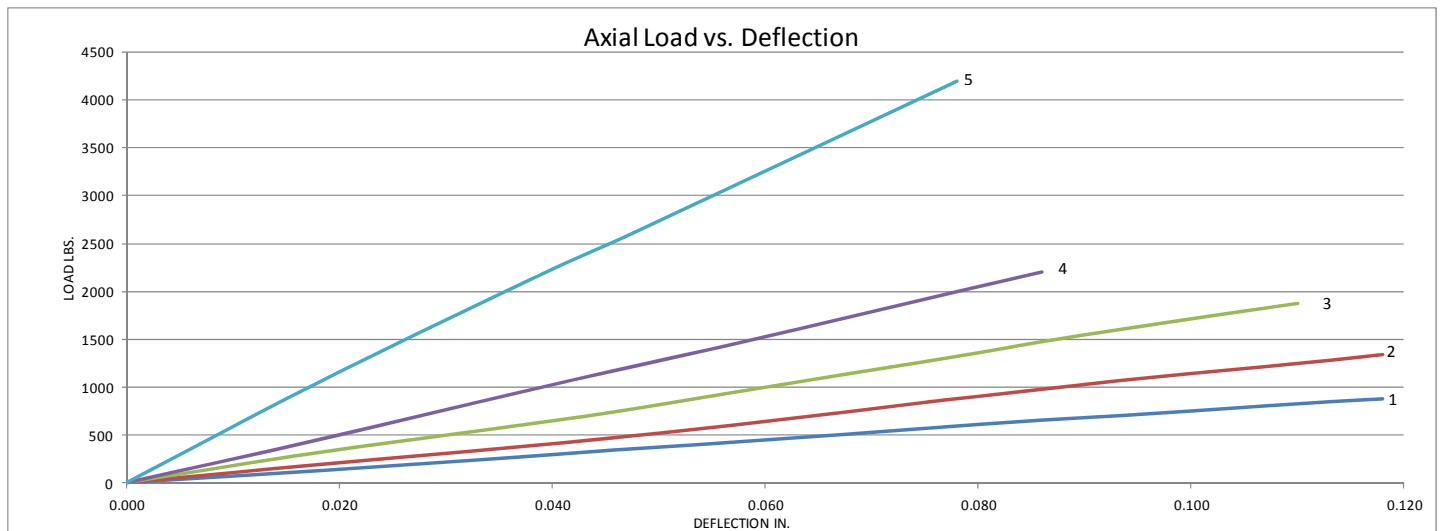
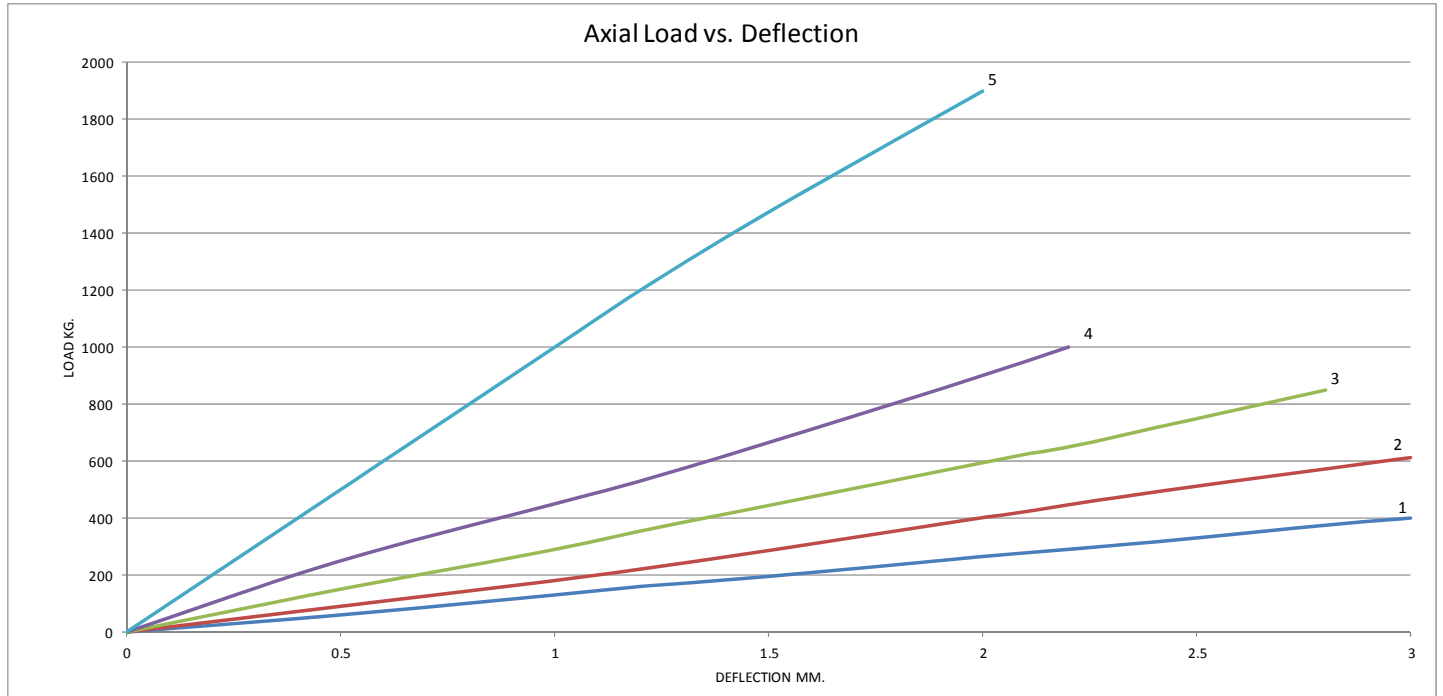

ARMORFLEX™ MOUNT SERIES



ArmorFlex™ Mount Series

2131-2133



Applications

- Marine engines
- Marine generators
- Off-highway equipment
- Construction equipment

Benefits

- Rugged construction
- All steel construction
- 3 sizes of mounts to handle loads up to 1750 lbs

Attributes

- Fail-safe
- Compact, low profile design
- Easy to install
- Zinc plated construction

Specifications

- Natural frequency—8-10 Hertz at rated load
- Transmissibility at resonance — 10 max (Neoprene)
- Standard material — zinc plated steel

Elastomeric Data

- Neoprene has an operating temperature range of -40°F to 200°F (-40°C to $+93^{\circ}\text{C}$), and is used where oil immersion is present
-

ArmorFlex™ Mount Series: 2131

Dimension and Performance Characteristics

Part Number	Load vs. Deflection Requirements	
	Load ± 15% lbs. (kg)	Deflection inches (mm)
2131-1	1100 (499)	.118 (3.0)
2131-2	1450 (658)	.118 (3.0)

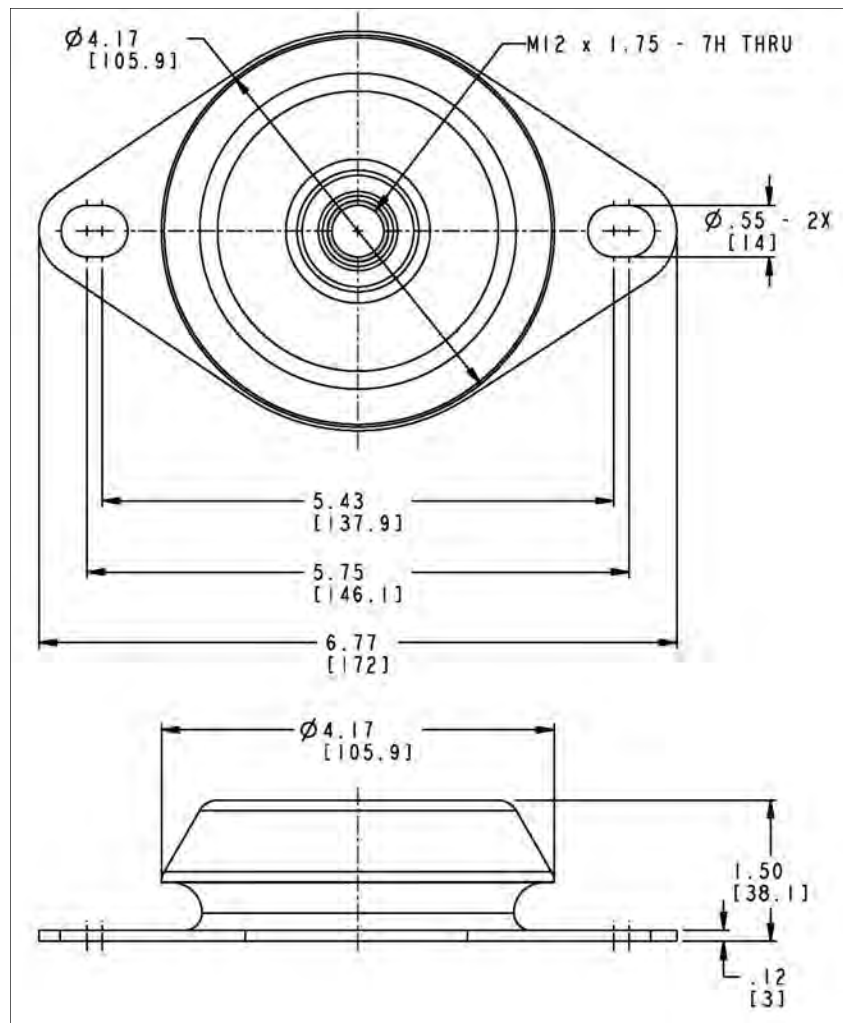

ArmorFlex™ Mount Series: 2131

Dimension and Performance Characteristics

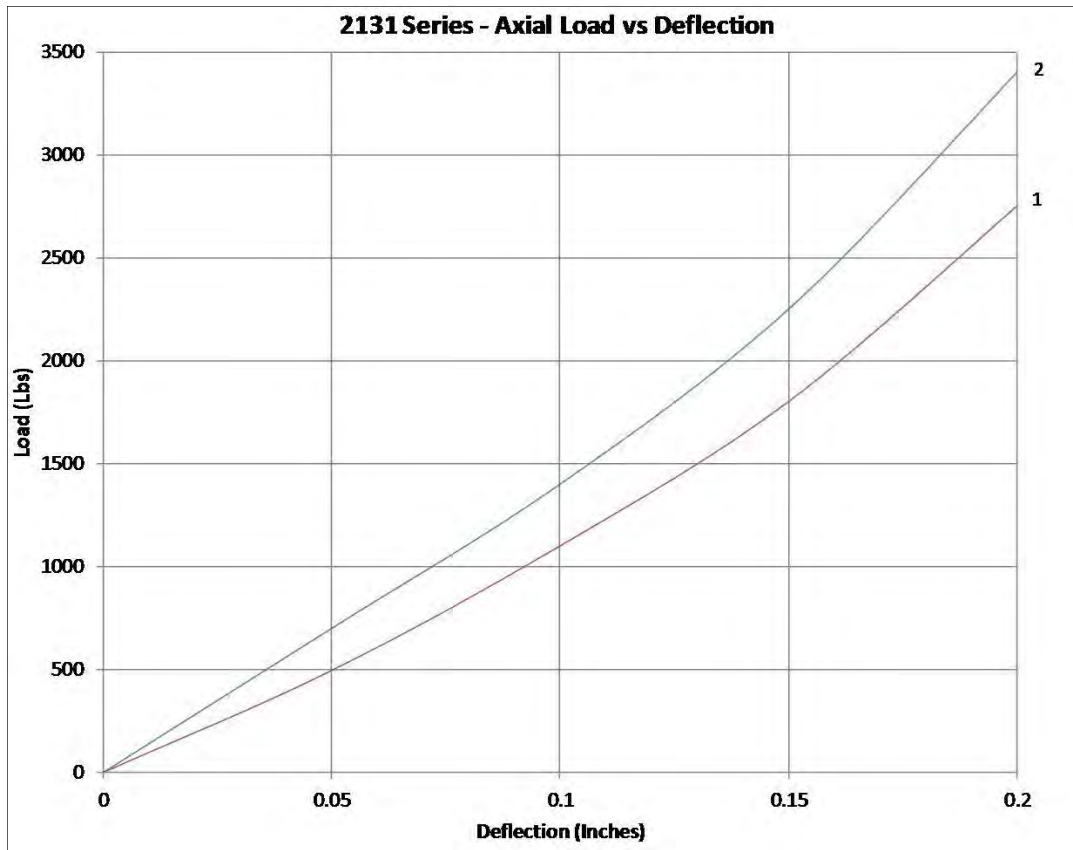

ArmorFlex™ Mount Series: 2132

Dimension and Performance Characteristics

Part Number	Load vs. Deflection Requirements	
	Load ± 15% lbs. (kg)	Deflection inches (mm)
2132-1	990 (449)	.118 (3.0)
2132-2	1550 (703)	.118 (3.0)

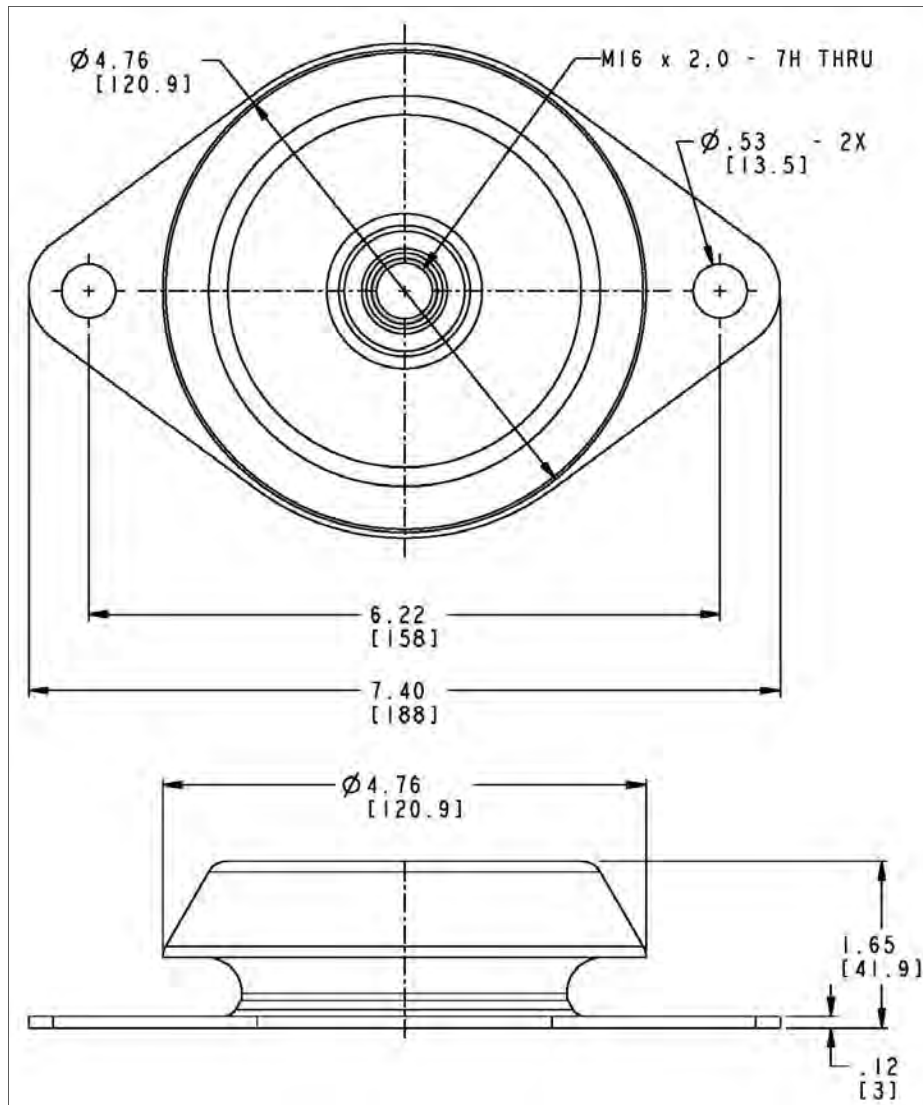

S

ArmorFlex™ Mount Series: 2132

Dimension and Performance Characteristics

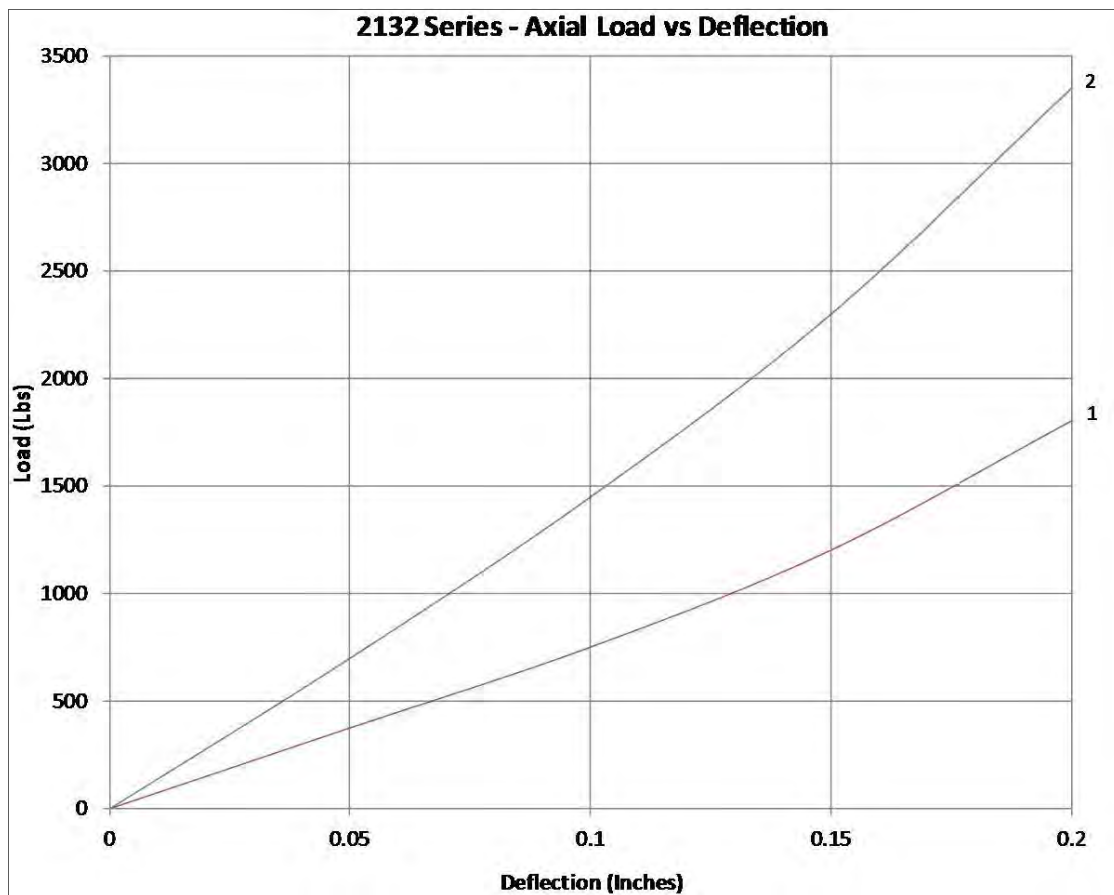

ArmorFlex™ Mount Series: 2133

Dimension and Performance Characteristics

Part Number	Load vs. Deflection Requirements	
	Load \pm 15% lbs. (kg)	Deflection inches (mm)
2133-1	990 (449)	.118 (3.0)
2133-2	1750 (794)	.118 (3.0)

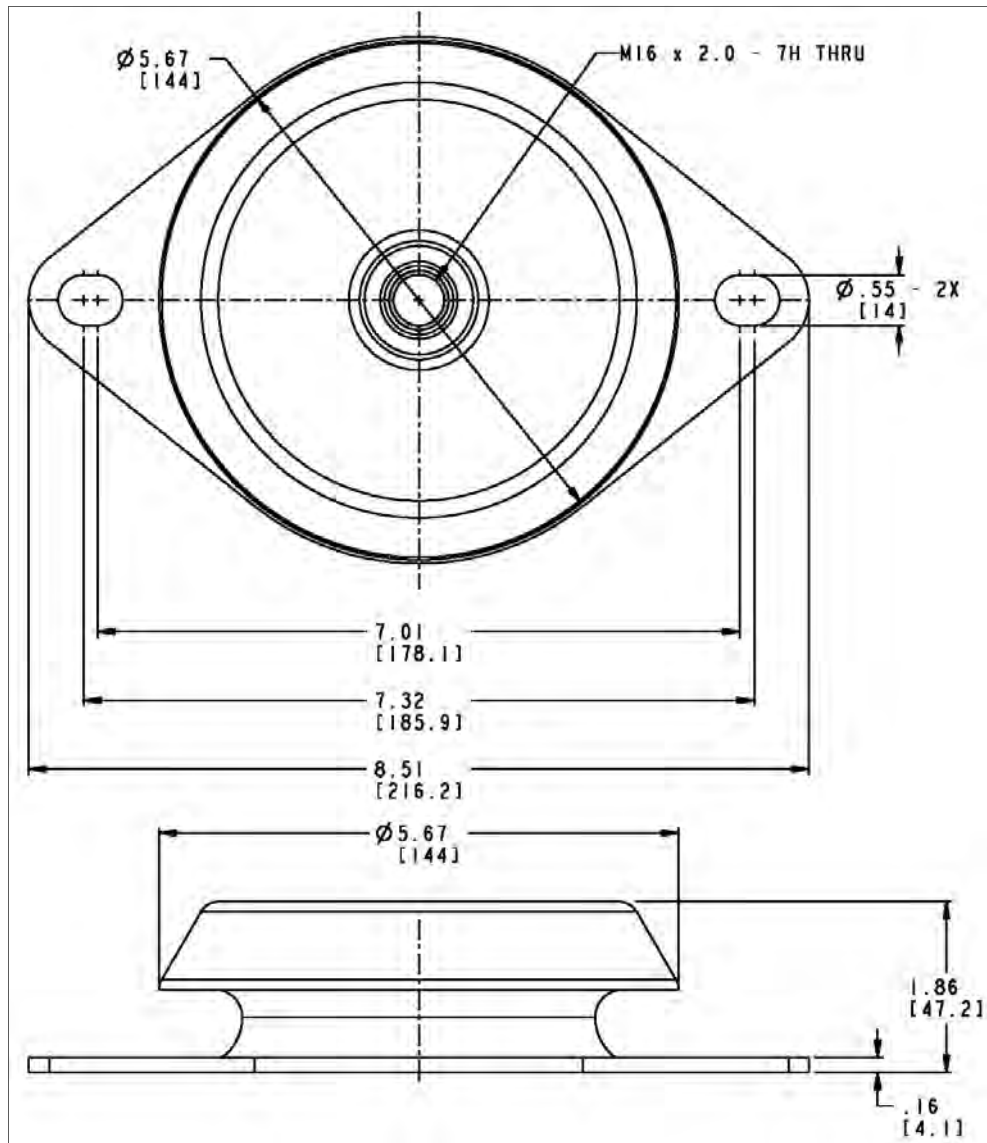

ArmorFlex™ Mount Series: 2133

Dimension and Performance Characteristics

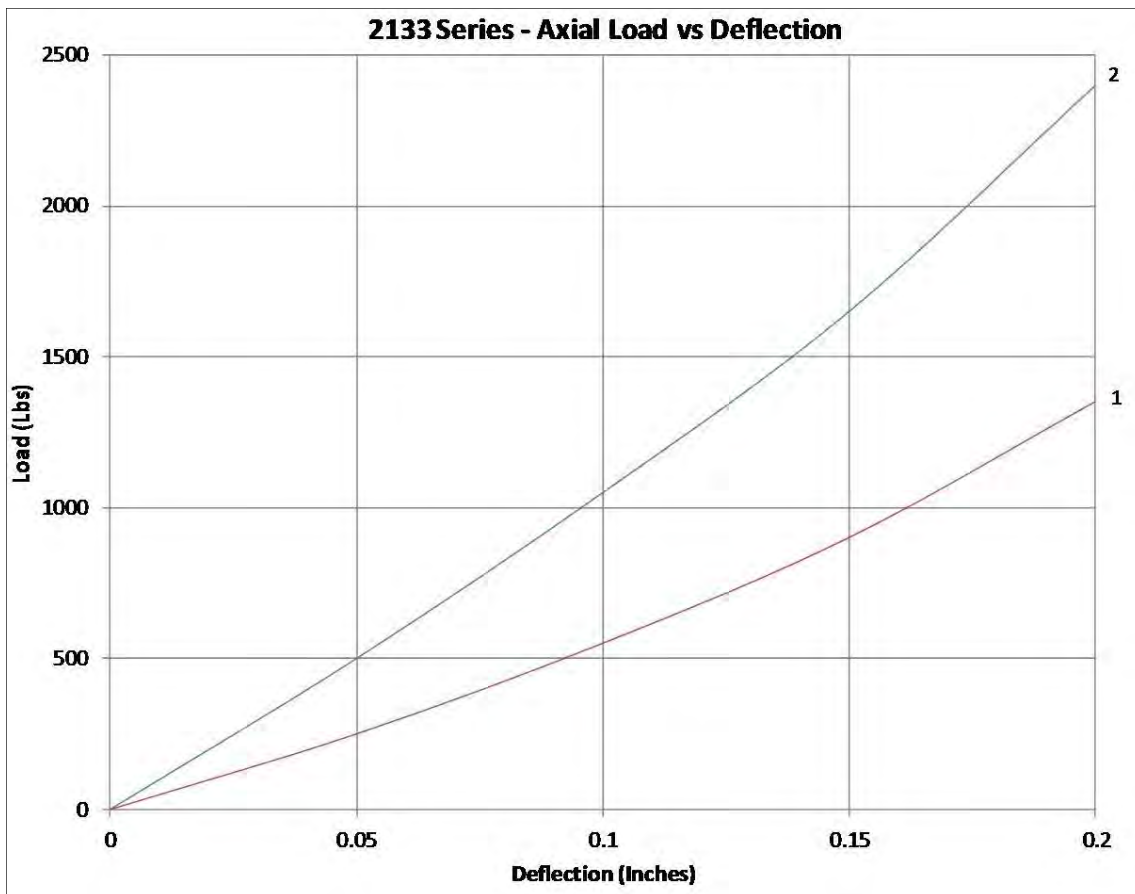

ArmorFlex™ Mount Series 2189



Attributes

- Fail-safe
- Compact, low profile design
- Easy to install
- Zinc plated construction

Applications

- Marine engines
- Marine generators
- Off-highway equipment
- Construction equipment

Benefits

- Rugged construction
- All steel construction
- Can handle loads up to 165 lbs.

Specifications

- Natural frequency - 8-10 Hertz at rated load
- Transmissibility at resonance - 10 max
- Standard material - zinc plated steel

Elastomeric Data

- Neoprene elastomer has an operating temperature range of -40F to +200°F (-40°C to +93°C) and is resistant to oil, most solvents and ozone



ArmorFlex™ Mount Series: 2189

Dimension and Performance Characteristics

Part Number	Load vs. Deflection Requirements	
	Load ± 15% lbs. (kg)	Deflection inches (mm)
2189-1	66 (30)	.118 (3.0)
2189-2	99 (45)	.118 (3.0)
2189-3	143 (65)	.118 (3.0)
2189-4	165 (75)	.118 (3.0)

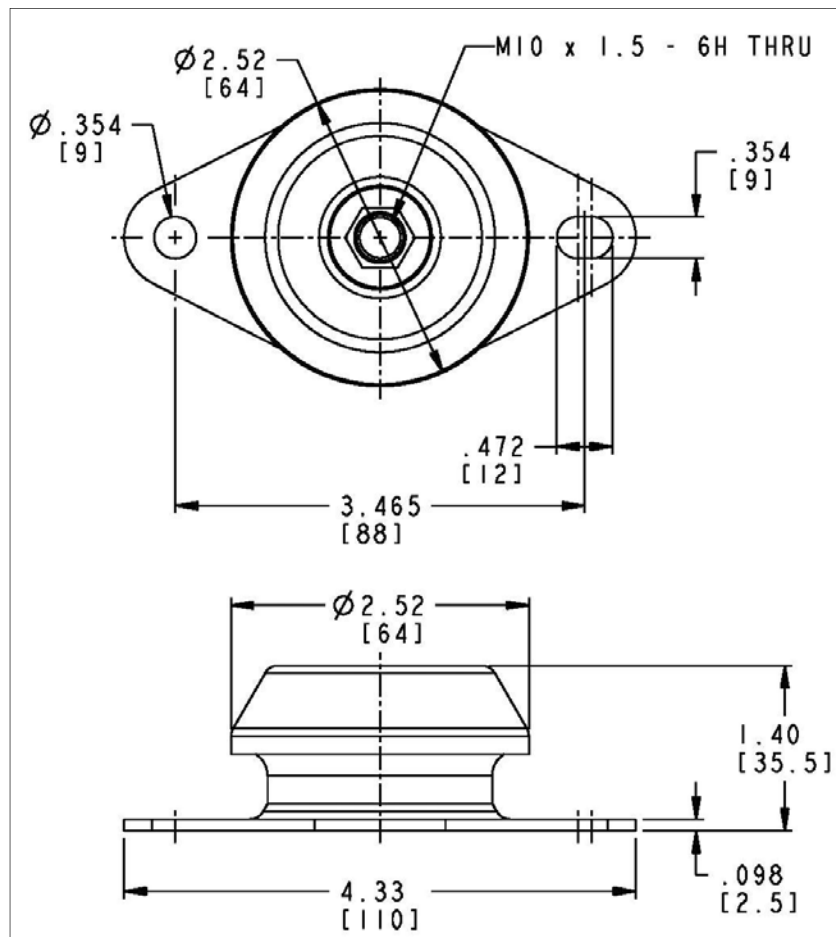

ArmorFlex™ Mount Series 2191



Attributes

- Fail-safe
- Compact, low profile design
- Easy to install
- Zinc plated construction

Applications

- Marine engines
- Marine generators
- Off-highway equipment
- Construction equipment

Benefits

- Rugged construction
- All steel construction
- Can handle loads up to 309 lbs.

Specifications

- Natural frequency - 8-10 Hertz at rated load
- Transmissibility at resonance - 10 max
- Standard material - zinc plated steel

Elastomeric Data

- Neoprene elastomer has an operating temperature range of -40F to +200°F (-40°C to +93°C) and is resistant to oil, most solvents and ozone.



ArmorFlex™ Mount Series: 2191

Dimension and Performance Characteristics

Part Number	Load vs. Deflection Requirements	
	Load ± 15% lbs. (kg)	Deflection inches (mm)
2191-1	110 (50)	.118 (3.0)
2191-2	165 (75)	.118 (3.0)
2191-3	265 (120)	.118 (3.0)
2191-4	309 (140)	.118 (3.0)

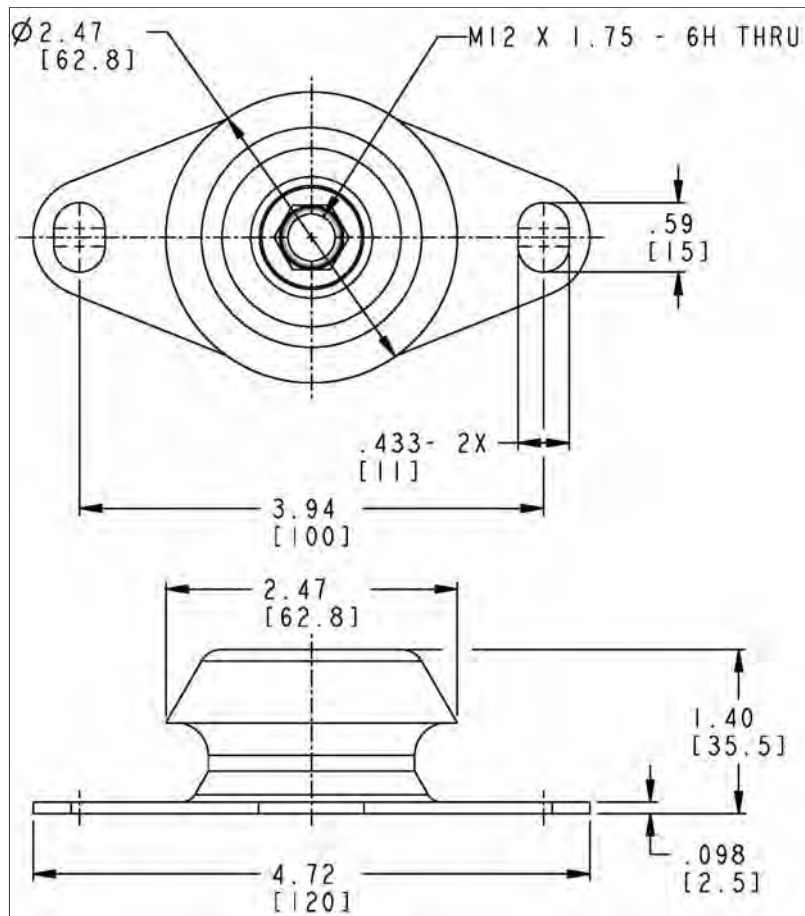

ArmorFlex™ Mount Series 2193



Attributes

- Fail-safe
- Compact, low profile design
- Easy to install
- Zinc plated construction

Applications

- Marine engines
- Marine generators
- Off-highway equipment
- Construction equipment

Benefits

- Rugged construction
- All steel construction
- Can handle loads up to 518 lbs.

Specifications

- Natural frequency - 8-10 Hertz at rated load
- Transmissibility at resonance - 10 max
- Standard material - zinc plated steel

Elastomeric Data

- Neoprene elastomer has an operating temperature range of -40F to +200°F (-40°C to +93°C) and is resistant to oil, most solvents and ozone.



ArmorFlex™ Mount Series: 2193

Dimension and Performance Characteristics

Part Number	Load vs. Deflection Requirements	
	Load ± 15% lbs. (kg)	Deflection inches (mm)
2193-1	176 (80)	.118 (3.0)
2193-2	287 (130)	.118 (3.0)
2193-3	386 (175)	.118 (3.0)
2193-4	518 (235)	.118 (3.0)

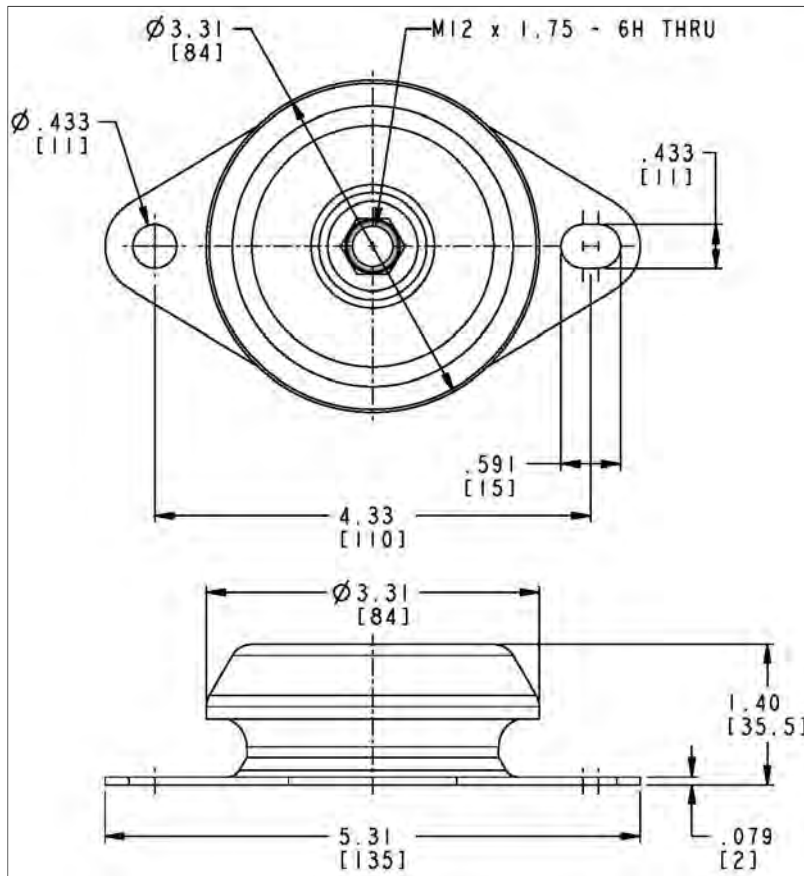

ArmorFlex™ Mount Series 2197



Applications

- Marine engines
- Marine generators
- Off-highway equipment
- Construction equipment

Benefits

- Rugged construction
- All steel construction
- Can handle loads up to 992 lbs.

Attributes

- Fail-safe
- Compact, low profile design
- Easy to install
- Zinc plated construction

Specifications

- Natural frequency - 8-10 Hertz at rated load
- Transmissibility at resonance - 10 max
- Standard material - zinc plated steel

Elastomeric Data

- Neoprene elastomer has an operating temperature range of -40F to +200°F (-40°C to +93°C) and is resistant to oil, most solvents and ozone



ArmorFlex™ Mount Series: 2197

Dimension and Performance Characteristics

Part Number	Load vs. Deflection Requirements	
	Load \pm 15% lbs. (kg)	Deflection inches (mm)
2197-1	441 (200)	.236 (6.0)
2197-2	673 (305)	.236 (6.0)
2197-3	926 (420)	.236 (6.0)
2197-4	992 (450)	.236 (6.0)

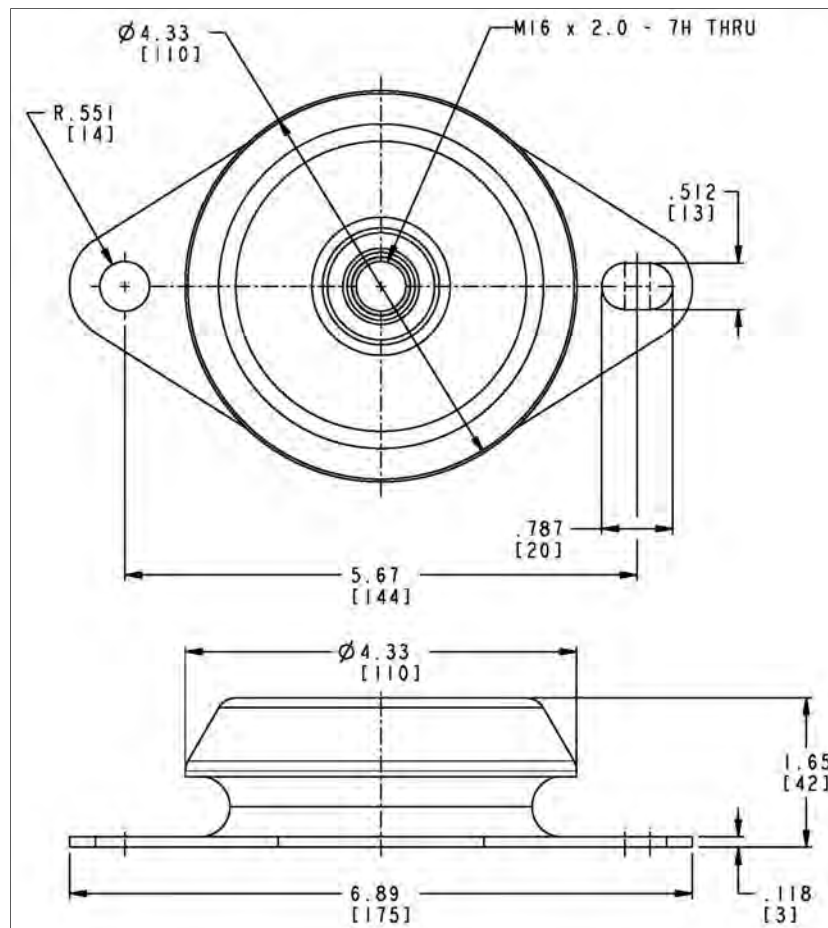

ArmorFlex™ Mount Series 2199



Applications

- Marine engines
- Marine generators
- Off-highway equipment
- Construction equipment

Benefits

- Rugged construction
- All steel construction
- Can handle loads up to 2205 lbs.

Attributes

- Fail-safe
- Compact, low profile design
- Easy to install
- Zinc plated construction

Specifications

- Natural frequency - 8-10 Hertz at rated load
- Transmissibility at resonance - 10 max
- Standard material - zinc plated steel

Elastomeric Data

- Neoprene elastomer has an operating temperature range of -40F to +200°F (-40°C to +93°C) and is resistant to oil, most solvents and ozone.



ArmorFlex™ Mount Series: 2199

Dimension and Performance Characteristics

Part Number	Load vs. Deflection Requirements	
	Load \pm 15% lbs. (kg)	Deflection Inches (mm)
2199-1	992 (450)	.118 (3.0)
2199-2	1257 (570)	.118 (3.0)
2199-3	1764 (800)	.118 (3.0)
2199-4	2205 (1000)	.118 (3.0)

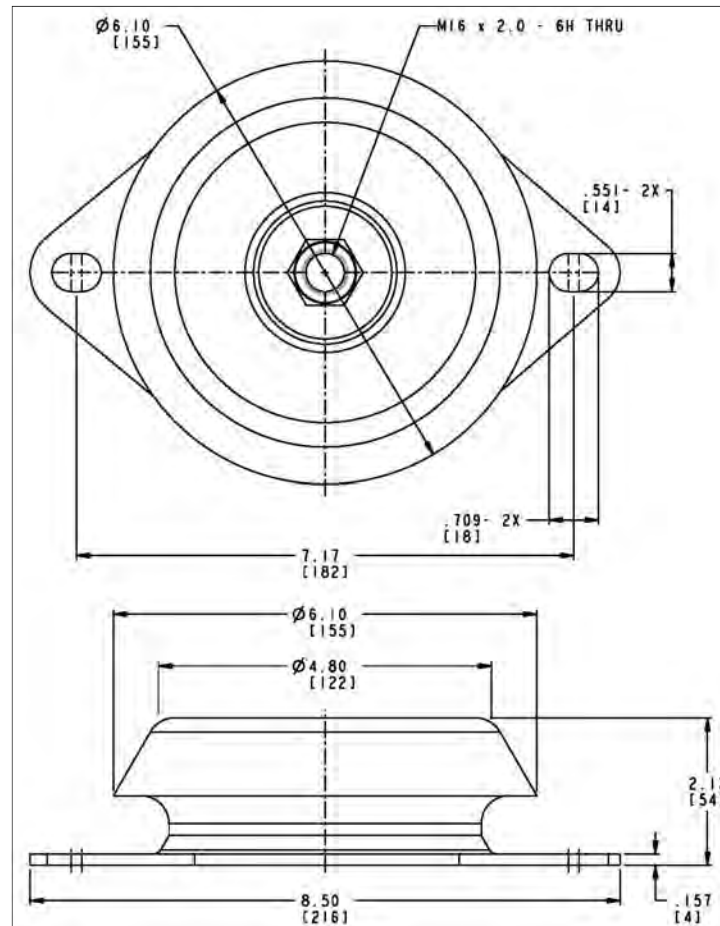

ArmorFlex™ Mount Series 2201

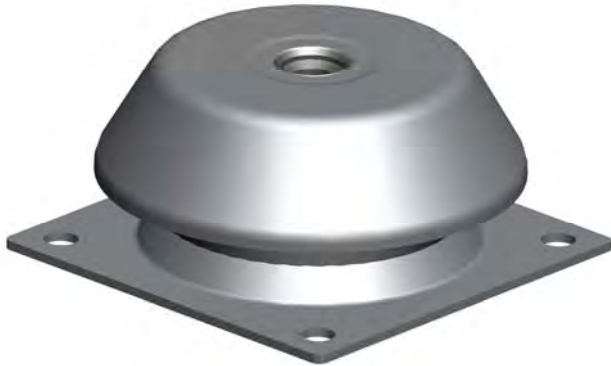

Applications

- Marine engines
- Marine generators
- Off-highway equipment
- Construction equipment

Benefits

- Rugged construction
- All steel construction
- Can handle loads up to 5799 lbs.

Attributes

- Fail-safe
- Compact, low profile design
- Easy to install
- Zinc plated construction

Specifications

- Natural frequency - 8-10 Hertz at rated load
- Transmissibility at resonance - 10 max
- Standard material - zinc plated steel

Elastomeric Data

- Neoprene elastomer has an operating temperature range of -40F to +200°F (-40°C to +93°C) and is resistant to oil, most solvents and ozone.



ArmorFlex™ Mount Series: 2201

Dimension and Performance Characteristics

Part Number	Load vs. Deflection Requirements	
	Load ± 15% lbs. (kg)	Deflection inches (mm)
2201-1	1929 (875)	.512 (13.0)
2201-2	2646 (1200)	.512 (13.0)
2201-3	3749 (1700)	.512 (13.0)
2201-4	5799 (2630)	.512 (13.0)

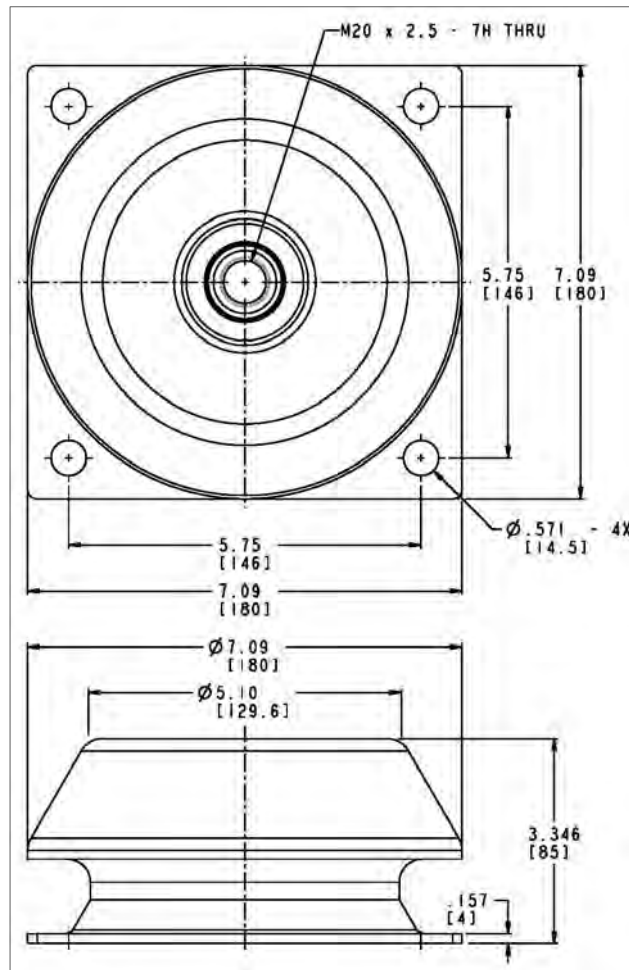

ArmorFlex™ Mount Series 2202



Applications

- Marine engines
- Marine generators
- Off-highway equipment
- Construction equipment

Benefits

- Rugged construction
- All steel construction
- Can handle loads up to 9261 lbs.

Attributes

- Fail-safe
- Compact, low profile design
- Easy to install
- Zinc plated construction

Specifications

- Natural frequency - 8-10 Hertz at rated load
- Transmissibility at resonance - 10 max
- Standard material - zinc plated steel

Elastomeric Data

- Neoprene elastomer has an operating temperature range of -40F to +200°F (-40°C to +93°C) and is resistant to oil, most solvents and ozone.



ArmorFlex™ Mount Series: 2202

Dimension and Performance Characteristics

Part Number	Load vs. Deflection Requirements	
	Load ± 15% lbs. (kg)	Deflection inches (mm)
2202-1	3528 (1600)	.394 (10.0)
2202-2	5292 (2400)	.394 (10.0)
2202-3	7497 (3400)	.394 (10.0)
2202-4	9261 (4200)	.394 (10.0)

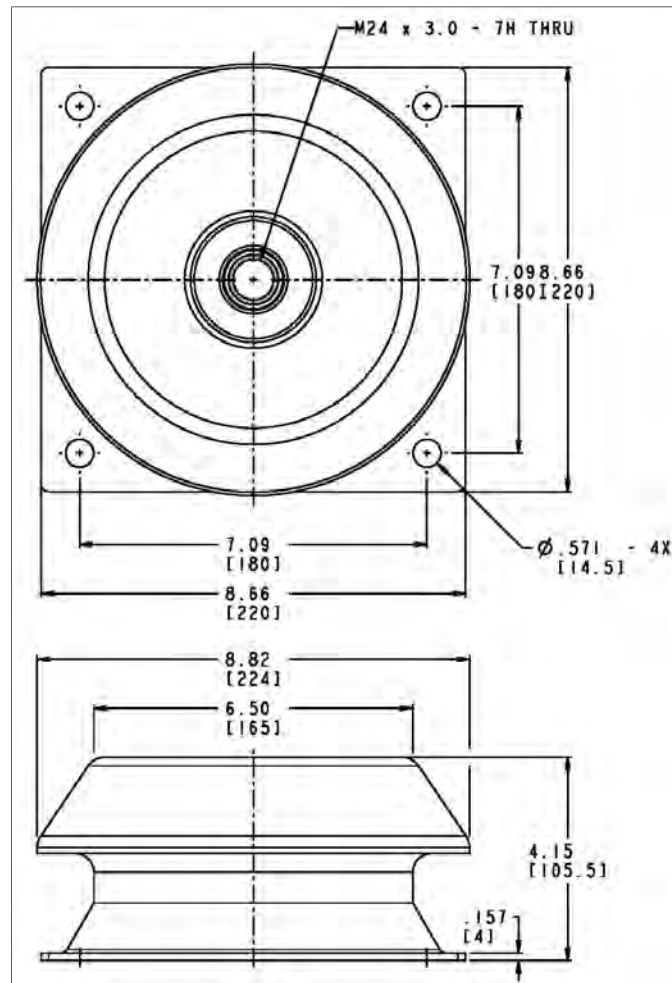

PRODUCT INFORMATION

Every effort has been made to ensure that the information contained in this catalog was accurate at the time of publication. Polymer Technologies Inc. reserves the right to make changes at any time without prior notice. Please contact us before using the information contained herein as the basis for your design or specification. This information is provided for reference only.

Polybond North America Inc

Experts in Vibration Isolation

Elastomeric Solutions



PBNA is a Massachusetts based engineering and manufacturing company established in 1993. PBNA is committed to providing its customers the highest quality of engineering and manufacturing and serves all equipment applications. PBNA integrates product design, material development, process development, and prototyping into plastic and elastomeric solutions. PBNA specializes in shock and vibration isolators, molded products, and custom material development utilizing rubber, urethane, silicone, and thermoplastic elastomers.

PBNA is the developer of DuraFlex® rubber, a trademarked, proprietary line of rubber compounds with ultra-high resiliency, low temperature rise, and long fatigue life. PBNA uses DuraFlex rubber compounds in some of the vibration isolators we manufacture. We also sell some of these compounds to other companies that mold tires, conveyor belts, and other products that benefit from the low temperature rise and long fatigue life of these materials. DuraFlex rubber is the lowest temperature rise rubber known to exist. One of the DuraFlex rubber formulas scored a 0° temperature rise on the Goodrich Flexometer test. DuraFlex rubber compounds also exhibit high abrasion resistance, high tensile strength, and high fatigue-life properties making them ideal tire compounds. Since announcing the development of DuraFlex rubber, we have received calls from all over the world with applications for the material and we continue to find new uses. Applications include tire, conveyor belt, military, and vibration equipment. If you would like more information about using DuraFlex rubber in your application, please go to the Contact Us section of the site.

PBNA is also the producer of CLDM, Constrained Layer Damping Material. This material is commonly used in aerospace applications to dampen circuit boards. Please find more information in the Standard Products section under Damping Materials.

PBNA is registered in the CCR, CAGE 1J8Z4.

Polybond North America, Inc.
76 Astor Avenue, Bldg. 101 • Norwood, MA 02062
1-781-762-3913 • www.polybondna.com
sales@polybondna.com

